



VAN-CONCEPT

CONVERSION

CATALOGUE 2024



CAMPERVAN
FURNITURE UNITS



SELF-ASSEMBLY
MODULES



BEDROOM/SEAT BENCH
SYSTEMS



SLEEPING- / LIFTING- /
HIGH ROOFS



EXPANSION
ACCESSORIES



www.reimo.com

Scan QR-Code
and discover the whole
REIMO expansion
diversity!





CAMPINGBOXES
10-17

**FORD TRANSIT CUSTOM
CAMPER VANS**

92-95

**MERCEDES-BENZ
CAMPER VANS**

76-85



**EXTENSION MODULES
FOR SELF-ASSEMBLY**
18-29



MINICAMPER
30-41

**RENAULT / OPEL / FIAT / NISSAN
CAMPER VANS** 86-91



**VOLKSWAGEN TRANSPORTER
CAMPER VANS**
42-75



CITROËN SPACETOURER

96-101



MAXICAMPER

102-107

VEHICLE ROOFS

108-145



SLEEP/SEAT-
BENCH SYSTEMS

146-169

Vacation dreams made in Germany!

Competence, Experience, Innovation & Quality for more than 40 years!

Quality through experience & tradition.

Over 40 years of experience in camping bus & motorhome conversion as well as motorhome equipment & technology, make us specialist in all questions of conversion & accessories.



Tradition obliges.

With this in mind, our claim is to build the best motorhomes and recreational vehicles based on panel vans. This claim applies in particular to safety-relevant aspects of our vehicle conversions. Components affected by this (e.g. roofs or bench seat systems) are developed and manufactured at Reimo in accordance with current European and international standards.



As early as 1983, we developed the first super-flat sleeping roof in Europe, which could be installed without welding in a frame. Over the years, safety requirements have increased, and a variety of tests have been prescribed for the various interior parts, such as sleeping roofs or even bench seats. After extensive tests especially with the bench seats by TÜV Rheinland, we were able to offer the first bench seats for retrofitting.

But we don't miss out on innovations either. Thus, we are constantly designing new extension products in our development department. Starting with new sleeping and loft roofs, of which we have already designed over 50 models in the last 40 years and sold more than 250,000 units worldwide. On top of that sleeping/seating benches, which offer a particularly high level of comfort, since you lie on the padded back without annoying belt buckles or an uneven seat surface. Last but not least, high-quality extension modules & furniture.

Especially for the extensions we offer a diverse selection. From complete conversion, such as the TrioStyle, to the Bike 'n' Surf, which is limited to the bare essentials and offers enough space for the bike for a weekend trip, to the practical campingbox, which contains everything you need for your vacation and can be installed and removed from your vehicle as needed.

Committed to people.

We develop and produce our finishing parts for the needs of our customers. High quality workmanship and well thought-out solutions are the main focus, so that all components can be used optimally in everyday life and on vacation.

We rely on employees, most of whom have been working for REIMO for a long time. And this exclusively at our locations in Germany. This also allows us to offer consistent quality. Made in Germany.

Copyright by Reimo Reisemobil-Center GmbH

All prices in € incl. 19 % VAT. Prices are valid until the publication of a new catalog. Delivery subject to change. All products without decoration. Misprints, errors and technical changes/further developments reserved. All data without guarantee. The permissible tolerance for technical data is +/- 5%. Water installations described in the content correspond to the state of the art 10/2007 (Directive 200772/EC). When installing Additional equipment ex works (or ex dealer) increases the unladen mass and accordingly the payload is reduced. Fig. partly show extras and decorations that are not in the scope of delivery or equipment for countries other than Germany. All rights reserved. Reprinting as well as use in electronic media, also in extracts, only with permission of Reimo Reisemobil-Center GmbH, Egelsbach.

Status: 02.02.2024

REIMO BEDROOM/BENCH SYSTEMS

Sleeping benches that provide extra comfort, sleeping on the padded back. Comfortable seating on 3 seats with belts and retractable headrests.

The sliding REIMO benches meet the highest standards Safety requirements. The sale and installation is only possible at trained specialist dealers.



REIMO SLEEPING ROOF

Proven safety and high comfort. High foot clearance thanks to large shears. Convenient to open, whether manually or electric. Enjoy the view with the 3 windows in the tent bellows or with the open-sky bellows almost like in open air.

Sale and installation is only possible at trained specialist dealers.



THE REIMO SELF-EXPANSION MODULES

For those who want to convert your vehicle into a camper yourself, we offer camping modules and kits for self-installation.

These products are specially marked with the "SELF INSTALL" logo.

For example, you can choose CampingBoxes, kitchen modules, beds and roofs. Items can also be ordered by private customers.



THE VOLKSWAGEN BODY VARIANTS

The right base vehicle for the expansion

Panel van, station wagon, Multivan or Caravelle?

Reimo explains the difference:

BODY VARIANT

PANEL VAN

This body variant is based on the Volkswagen Transporter. Today's cargo space is more uncompromising than ever in terms of functionality and versatility.

The panel van is shipped from the factory without rear glazing and requires special interior trim and insulation.

The interior (furniture) must be adapted to this particular cladding. Camping bus windows can be retrofitted by REIMO according to your needs and furnishing concept.

BODY VARIANT

STATION WAGON

Reimo has adapted the facilities of most small camping buses to the station wagon body variant. For interior trim, the station wagon usually has a simple, non-bulky trim.

Therefore, it offers the most usable space for interior decoration. This allows for more bed width and a longer bed length in the Volkswagen Station Wagon model (compared to the Caravelle).

The exterior appearance of the Volkswagen station wagon has passenger car appeal. The large window areas provide plenty of light in the vehicle and allow good all-round visibility in city traffic.

BODY VARIANT

CARAVELLE®

The Caravelle® model from Volkswagen is equipped ex works with visually appealing interior trim and a number of additional comfort features. Sophisticated and high quality.

However, valuable interior width and length is lost due to the generous interior paneling.

In case of the roof structure (pop-up or sleeping roof), special cladding is elaborately adapted. REIMO has developed its own interior versions such as TrioStyle and CityVan for the Volkswagen Caravelle®.

Dimensions of furniture and roofs are adapted to the Caravelle®. The installation time for the Caravelle® is significantly longer than for the estate body variant due to the necessary adjustments to the standard cladding.

BODY VARIANT

MULTIVAN®

Like the REIMO CityVan and the REIMO Weekender, the Multivan® is a multifunctional recreational vehicle and ideal for weekend trips or short breaks.

The standard equipment offers only limited possibilities for conversion to a full camping bus. For longer vacations, campers with more extensive equipment are more suitable.

At REIMO you can get many supplementary elements for retrofitting for more living, sleeping & kitchen comfort for Multivan®. For example, bed pads, roof storage boxes or mobile kitchen modules.

The designations for box, station wagon and luxury bus are different among vehicle manufacturers. Caravelle and Multivan are registered trademarks of Volkswagen AG.

THE VEHICLE LENGTHS

The right base vehicle for the expansion

Short, long or extremely long wheelbase?

REIMO produces camping bus equipment for vehicles with different wheelbases.

SMALL CAMPING BUSES

2 WHEEL STANDS

Many small buses such as Volkswagen Transporter, Mercedes-Benz Vito, Renault Trafic or Opel Vivaro are available in 2 wheelbases.

Short wheelbases (SWB) are usually preferred for these vehicles because of their maneuverability **and the parking situation in large cities**. The **long wheelbases (LWB)** offer approx. 40 cm more interior length(at Volkswagen) and thus also more living space!



More information:
www.reimo.com

BIG CAMPING BUSES

3 WHEEL STANDS

Many large buses such as Volkswagen Crafter, Mercedes-Benz Sprinter, Fiat Ducato or Iveco Daily are available in 3 or more wheelbases. In the case of large buses, **medium wheelbase is usually** preferred for expansion. Upon request & agreement, REIMO can usually supply components for all wheelbases.

The facilities for large camping buses are adapted to the van body variant-tuned. This body variant does not have pre-installed windows. This offers the possibility to install windows only where they are needed.

Sometimes body variant is chosen with standard windows in sliding door & on the opposite side of the vehicle.



QUALITY CAMPING BUS FURNITURE MADE IN GERMANY

Innovative and durable

REIMO Originals

The peculiarities of REIMO developments

Furniture panels

REIMO furniture panels are characterized by a particularly good suitability for the finishing of vehicles. The support material made of poplar plywood is extremely light and torsion-resistant due to the 7-fold gluing. At the same time, it is a natural product and a very economical solution.

The very robust surface finish (high impact and scratch resistance) is achieved by coating both sides with high-quality laminate in HPL or CPL quality (HPL = High Pressure Laminate / CPL = Continuous Pressure Laminate). This makes the furniture incomparably more durable, less sensitive to temperature fluctuations and more durable than, e.g. furniture with foil coating.

Another advantage of REIMO furniture boards is the possibility of clean processing them with normal, standard tools.

Quick-Fit-Solid-Art®

REIMO furniture has a clever and particularly stable connection technology: the REIMO Quick-Fit-Solid-Art® system. The clear assignment and positioning of the parts makes assembly almost child's play for both laymen and professionals. The friction-locked interlocking of furniture parts reduces noise development and guarantees the well-known durability of REIMO furnishings. As a result, the furniture carcass after screwing has a very high stability.

(Quick-Fit-Solid-Art® is a registered trademark of Reimo Reisemobil-Center GmbH)



Guaranteed quality

Over many years we learned that stability, appearance and utility value of a piece of furniture depend on high-quality materials and precise manufacturing. REIMO has therefore been manufacturing the interiors on computer-controlled processing since 1988. So that the dimensions are correct and the repeatability is given!

Extensions

REIMO – manufacturing motorhomes for over 40 yrs. For more fun and joy on vacation REIMO wants to meet the wishes and ideas of customers, especially with individual extensions.

Over the years, many individual productions have become series modules, giving you the security of tried and tested elements.

We therefore recommend that - if possible - you choose an interior that has already been built frequently in a series module. Of course, the price is also lower than custom made.



Individual facilities

Reimo devices are intended for installation in the empty vehicle without additional equipment from the manufacturer, such as heat exchanger or original plastic interior trim. The floor structure is based on our floor slab with a total thickness of approx. 25 mm. Deviations from this basic equipment may require adaptation work/additional effort. The CityVan equipment cannot be used in conjunction with the full fairing and integrated roller blinds.

The devices are aligned to the vehicle-specific bench and to the technical equipment with the defined components and possibly provided with cutouts for them.

Of course, we advise our customers with our many years of experience.

Nevertheless, each individual vehicle remains a prototype the first time, which may not be perfect in all details!



ADVANTAGES OF OUR MATERIALS

Know-How and experience for highest travel and vacation comfort

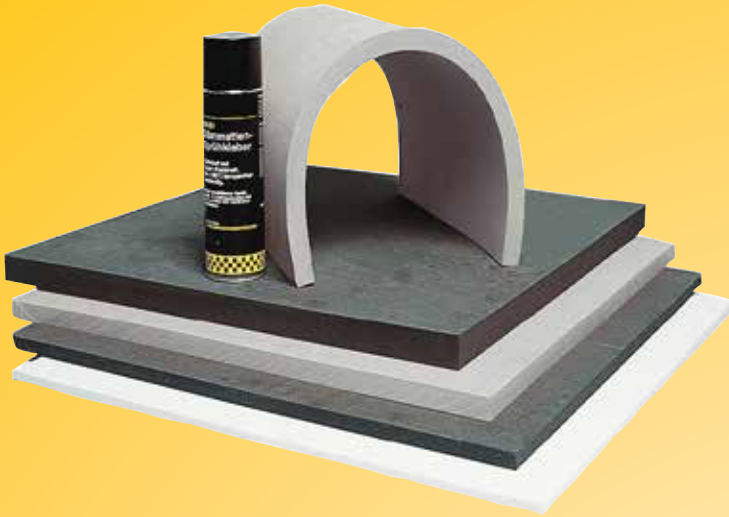

Insulation - with REIMO insulation sets

REIMO complete vehicles are extensively insulated against sound and heat.

A significant reduction in condensation and simultaneous thermal insulation is achieved by insulating interior sheet metal surfaces and partial cavities with REIMO's Xtrem insulator in various thicknesses.

On request, the self-adhesive CARBEST anti-drumming mat can also be applied to the sheet surfaces to optimize sound insulation. The insulation set is then attached with Sika adhesive.

Interior trim

For vehicle interior trim, REIMO uses and offers materials that are homely and highly efficient in terms of sound and heat. Here, hardboard or light plywood panels are covered with laminated isovelour or a felt.

These materials can absorb and release moisture. Alternatively, laminated imitation leather is available as a particularly easy-care solution.

All of these REIMO materials are particularly stretchable so that they can be optimally molded to car body contours. To ensure they adhere well over long term, we recommend using the high-heat spray adhesive (REIMO item no. 500130).



REIMO vehicle roofs made of GRP

REIMO roofs are offered in 2 different types of construction:

The low-cost, single-ply roof has a high-gloss exterior or top surface and a slightly rougher underside. From the bottom, the largest area (bed and living area) is usually covered with homely isovelour.

The more modern, double-skin roof (e.g. also V-TEC series) offers top and bottom surfaces in GRP gelcoat high-gloss. This design allows for a high-strength, elegant shape with an even higher quality finish. The smooth surfaces also make it easier to clean.

Tent bellows fabrics

REIMO sleeping roofs are equipped with different tent bellows fabrics:

Even the conventional tent bellows shines compared to the classic Cotton tent bellows, among other things, due to very good breathability and improved maintenance properties. It offers plenty of light and air through the opening side windows and the front window.

The new Climagic tent bellows impresses through newly developed synthetic material with even better breathability, improved weather resistance and easy maintenance.

Those who want to enjoy the view and plenty of fresh air can opt for the OpenSky variant, which is easy to open with a zipper.



Mosquito nets

The insect protection nets installed by REIMO in tent bellows are particularly appreciated due to their tight mesh and robustness. They are equipped with high quality zippers. All this also applies to the mosquito nets for doors, windows and tailgates offered as accessories.





REIMO VAN-CONCEPT

REIMO CAMPINGBOXES





With the REIMO CampingBox, your everyday vehicle becomes a camper for short vacations, or weekend trips in no time. Suitable for minicamper such as Caddy Maxi, Berlingo, Spacetourer or Jumpy. The multifunctional CampingBoxes are also available for Volkswagen T6.1/T6/T5 as well as Volkswagen Multivan, Volkswagen California Beach or Mercedes-Benz Vito. The REIMO CampingBoxes - practical rear kitchen modules with storage system.



SELF INSTALL

SELBST EINBAUEN

• CONTENT •

	CAMPING BOX L FOR VOLKSWAGEN T6.1/T6/T5, MERCEDES-BENZ VITO, RENAULT TRAFIC	13
	CAMPING BOX M FOR MINICAMPER LIKE VOLKSWAGEN CADDY AND MERCEDES-BENZ CITAN	14
	CAMPING BOX LCM FOR VOLKSWAGEN T6/T5 CALIFORNIA BEACH + MULTIVAN	15
	CAMPING BOX WV FOR VOLKSWAGEN T6/T5 WEEKENDER AND MERCEDES-BENZ VITO WEEKENDER	16
	LUGGAGE DRAWERS / LUGGAGE BUTLER	17

WHICH CAMPING BOX FOR WHICH VEHICLE?

The multifunctional CampingBoxes from REIMO are available in different versions, suitable for many vehicle brands and models. The following table shows which CampingBox fits in which vehicle types.

Vacation dreams 
made in Germany!

Vehicle type	YOC.	Plastic-Interior trim	CampingBox L	CampingBox M	CampingBox LCM	CampingBox WV
Volkswagen Caddy 4 SWB	2003 - 2019	with		•		
Volkswagen Caddy 4 LWB (Maxi)	2008 - 2019	with		•		
Volkswagen Caddy 5 LWB (Maxi)	as of 2020	with		•		
Volkswagen ID. Buzz NWB	from 2022	with		•		
Volkswagen Transporter 6.1 / 6 / 5 SWB + LWB Station wagon + Caravelle	as of 2003	with	•			
Volkswagen Transporter 6.1 / 6 / 5 California Beach w/ 3-seater bench & reclining function	as of 2003	with			•	
Volkswagen Transporter 6.1 / 6 / 5 SWB + LWB Multivan w/ 3-seater bench & reclining function	as of 2003	with			•	
Volkswagen Transporter 6.1 / 6 / 5 SWB + LWB REIMO Weekender	as of 2003	with				•
Mercedes-Benz Citan Estate SWB 1	2012 - 2021	with		•		
Mercedes-Benz Vito Tourer long + extra long	as of 2003	with	• (without bed module)			
Mercedes-Benz Vito Tourer long + extra long	as of 2003	without	•			
Mercedes-Benz V-Cash + EQV, Viano long + extra long	as of 2003	with	• (without bed module)			
Mercedes-Benz Vito Tourer long REIMO Weekender	as of 2015	with				•
Mercedes-Benz V-Class / EQV long REIMO Weekender	as of 2015	with				•
Renault Kangoo II	2008 - 2021	with		•		
Renault Trafic 2, 3, SWB + LWB station wagon	as of 2001	without	•			
CitroënBerlingo 2 Multispace	2008 - 2018	with		•		
CitroënSpacetourer M + XL	from 2016	with		•		
CitroënJumpy M + XL	from 2016	without		•		
Peugeot Partner 2 Tepee	2008 - 2018	with		•		
Peugeot Traveller M + XL	from 2016	with		•		
Peugeot Expert M + XL	from 2016	without		•		
Opel Zafira Life	as of 2020	with		•		
Opel Vivaro A + B	2001 - 2021	without	•			
Opel Vivaro C	as of 2020	without		•		
Nissan NV 200, Evalia	2009 - 2021	with		•		
Nissan NV 250	2019 - 2020	with		•		
Nissan Primastar, NV 300, SWB + LWB station wagon	as of 2001	without	•			
Toyota ProAce Verso L1 + L2	from 2016	with		•		
Toyota ProAce L1 + L2	from 2016	without		•		
Fiat Talento SWB + LWB	2016 - 2021	without	•			
Fiat Ulysse 3 M + XL	from 2022	with		•		
Fiat Scudo 3 M + XL	as of 2021	without		•		
Ford Connect LWB	as of 2023	with		•		

CAMPINGBOX L

Suitable for Volkswagen Transporter 6.1/6/5, Mercedes-Benz Vito, Renault Trafic and others.

The multifunction box for Volkswagen Transporter 6.1/6/5, Vito & Co.



- Rear kitchen module with practical storage system
- Easy installation without modifications to the vehicle
- High quality HPL surfaces
- Extensive standard equipment such as folding sink, storage boxes & water canisters
- Expandable with optional bed module with large lying surface
- Compactly dismountable & space-saving for storage

Suitable for the following vehicles:

- Volkswagen Transporter 6.1 / 6 / 5 Estate or Caravelle, short/long wheelbase
- Mercedes-Benz Vito long and extra long (without plastic cladding)
- Fiat Talento/Nissan NV 300/Renault Trafic/ Opel Vivaro B, short/long wheelbase (without plastic cladding)

Removable kitchen box with folding sink incl. 2x 10-liter water cans with outlet tap.

With the optional aluminum folding stand, the kitchen pullout can be placed outside the vehicle. Comfortable, large lying surface on the optional bed module. (Picture shows bed module in Volkswagen T6 Caravelle). The optional 14-liter compressor cooler can be pulled out & removed and is powered by 12 V on-board power supply. Behind the 3 removable storage boxes (size M) is additional storage space ideal for optional accessories:

- Porta Potti 335 camping toilet or
- 3 additional storage boxes (3x size M) or
- 2 additional storage boxes (1x size M + 1x size Cube)

Scope of delivery:

- Left kitchen pull-out is equipped with folding sink, two 10-liter fresh water canisters with outlet tap and 2 drawers
- Right pull-out for optional cool box, (16-liter compressor cool box possible, powered by 12 V on-board power supply)
- 3x removable storage boxes (size M) each with lid

CampingBox L, Dims.: WxDxH: 118x60x80 cm
13250 1699,-

Bed module for CampingBox L incl. cushion, sleeping surface 200 x 150 cm
13251 1399,-

Optional accessories:

14 l compressor cooler 713544 379,-

16-liter compressor cooler 71440 566,-

Porta Potti 335 Cube 660102 149,-

Storage box w/ lid (size M, 18 liters)
Dims. app.: 40x34x17 cm 94915 9,-

Storage box w/ lid (size Cube, 27 liters)
Dims. app.: 40x34x27 cm 94916 10,90

Cartridge stove Camp Bistro DLX
With safety lock system and piezo ignition.
Power: 2200 W 706474 64,99

Cutlery tray, 4 compartments
922582 3,99

Cooler box stand

Adjustable in height and width. Loadable up to 30 kg. Dims.: H31xW42 cm / H40xW47 cm
Weight: app. 2 kg. 91062 29,95

Tail Tent Upgrade 2 Is put over the open tailgate. No linkage required. With PVC window in roof. Color: Grey/Anthracite/Lime. 936280 159,90

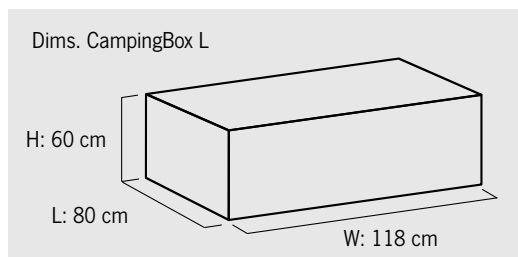

CAMPINGBOX M

Suitable for Volkswagen ID. Buzz, VW Caddy 3, 4, 5, Citroën Berlingo II, Renault Kangoo II & others



From everyday vehicle to mini camper.

- Combines functional rear kitchen with a clever storage system
- Easy installation without modifications to the vehicle
- Extensive standard equipment
- Bed module with large lying surface optional
- Folding table on the side
- Compactly dismountable & space-saving for storage

Suitable for the following vehicles:

Volkswagen ID. Buzz NWB
 Volkswagen Caddy (2003-2019)/Caddy Maxi (2008-2019)/
 Caddy Maxi 5 (from YOC. 2020)
 Citroën Berlingo Multispace (2008-2018)/
 Spacetourer/Jumpy (from YOC. 2016)
 Peugeot Partner Tepee (2008-2020)/
 Traveller/Expert (from YOC. 2016)
 Renault Kangoo II SWB (from YOC. 2008)
 Mercedes-Benz Citan station wagon SWB (from YOC. 2016)
 Toyota Proace Verso/ Proace (from YOC. 2016)
 Nissan NV 200/ NV 200 E/Evalia (from YOC. 2009)
 Opel Vivaro C/Zafira Life (from fall 2019)
 Ford Connect LWB (from YOC. 2023)

Scope of delivery:

- Left kitchen pullout equipped w/ a folding sink & a 10-liter fresh water canister w/ outlet tap
- Right-hand pull-out for optional 15-liter compressor cool box. This is removable & is powered by 12 V on-board network
- 2x removable storage boxes w/ lids 1x size M (18 l), 40x34x17 cm 1x size Cube (27 l), 40x34x25 cm

Cookware also has its place in kitchen pullout. This is removable and can be placed outside the vehicle on an optional aluminum folding stand.

CampingBox M,

WxHxD app. 111x47x74 cm **13252** **1529,-**

Bed module for CampingBox M

incl. cushion, installation material & instructions, sleeping surface app. 195 x 120 cm

13253 **1199,-**

NEW iD. Buzz bed module for camping box M

Sleeping area 195 x 130 cm **13216** **1239,-**

Optional accessories:

15-liter compressor cooler

713690 **599,-**

Storage box M, 18 l **94915** **9,-**

Dust box Cube, 27 l **94916** **10,90**

Cartridge stove Camp Bistro DLX With safety lock system and piezo ignition. Power: 2200 W, dims.: W37xD28xH12 cm, weight: app. 1.9 kg **706474** **64,99**

Cutlery tray, 4 compartments

922582 **3,99**

Cooler box stand

Adjustable in height and width. Loadable up to 30 kg. Dims.: H31xW42 cm / H40xW47 cm Weight: app. 2 kg. **91062** **29,95**



Cooking & washing up while standing, without bending down. Removable kitchen box with folding sink and 1x 10-liter water canister and storage space for cookware. The optional 15-liter compressor cool box can be pulled out & removed & is powered by 12 V on-board power supply.

Optional comfortable and quickly assembled bed. Cushion is attached to the box in the rear by Velcro and is attached to the headrests in the front by means of straps (Volkswagen Caddy SWB). On other vehicles, on the seat belt attachments of the B-pillars.

REIMO CampingBox can be disassembled and can thus be stored in the basement or garage to save space.



Dims. CampingBox M

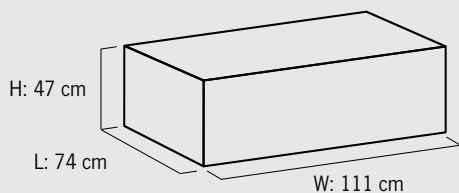

CampingBox in the Volkswagen ID. Buzz

CAMPINGBOX LCM

Suitable for Volkswagen Transporter 6.1/6/5 Multivan and California Beach



CampingBox with clever storage system.

- Combines functional rear kitchen with a clever storage system for all kitchen and cooking equipment
- Easy installation without modifications to the vehicle
- The Volkswagen sleeping bench is supplemented with a cushion pad on the camping box
- The CampingBox replaces Volkswagen Multiflex-Board
- Includes side folding table for more work space
- You will find further extensive accessories at www.reimo.com

- The clever addition for the Volkswagen T6.1/ T6 / T5 Multivan SWB or LWB or California Beach, each with 3 original seats
- Perfect handling and ideal height with the tailgate open

Box is fastened in luggage compartment to floor rails or lashing eyes on the vehicle side. Side carrying handles facilitate handling. No modifications to vehicle are required for installation.

Scope of delivery:

- Left kitchen pullout equipped w/ a folding sink & a 12-liter fresh water canister w/ outlet tap
- 2 removable storage boxes w/ lids 1x size M (18 l), 40x34x17 cm 1x size Cube (27 l), 40x34x25 cm
- Right-hand pull-out for optional 15-liter compressor cool box (powered by 12 V on-board power supply).

Behind 2 removable storage boxes is additional storage space, ideal for optional accessories:

- Porta Potti 335 camping toilet or
- Additional storage box (1x size Cube) Add a sleeping cushion to the rear area of the original 3-seater bench seat. Thus, Volkswagen Multiflexboard is not required for bed construction.

CampingBox LCM Dimensions: approx.
118x47x80 cm. **13254 1999,-**

Optional accessories:

- Comfort cushion** 13254P 379,-
- Compressor cooler 15 l** 713690 599,-
- Porta Potti 335 Cube** 660102 149,-
- Storage box w/ lid (size M, 18 liters)**
Dims. app.: 40x34x17 cm **94915 9,-**
- Storage box w/ lid (Cube, 27 liters)**
Dims. app.: 40x34x27 cm **94916 10,90**
- Cartridge stove Camp Bistro DLX**
With safety lock system and piezo ignition.
Power: 2200 W **706474 64,99**
- Cutlery tray, 4 compartments**
92258 23,95
- Melamine tableware set LIFE IS A JOURNEY**
16-piece set for 4 people. Dishwasher safe 4 dinner plates Ø 25 cm, 4 dessert plates Ø 20 cm, 4 bowls Ø 15 cm (650 ml), 4 cups with handle (400 ml). **917970 44,99**
- Drinking glasses Capri, material SAN, 2 pcs.**
Food safe and free from harmful substances.
Volume app. 300 ml. **929177 9,50**
- Fresh food box including lid, 1 piece**
Volume app. 900 ml. 4-way quick release, dishwasher, microwave and freezer safe. Food safe.
94055 2,21
- Aluminum cookware Elite, 5 pieces**
With folding handles. 1 pot (1.7 l), 1 pot (2.7 l), 2 lids, 1 pan Ø approx. 19 cm. Weight only app. 0.8 kg **92303 64,99**
- Stainless Steel Flute Kettle Compact**
Volume approx. 1.5 l. With whistle and insulated fold-down handle. **922193 15,95**



Cooking & washing up while standing, without bending down. Kitchen pullout w/ folding sink & 1x 12-liter water canister.

The spacious utensil folding section provides enough storage space for a cookware, 16-piece dinnerware set for 4 people, 4 drinking glasses, 2 cereal bowls & 4 food storage containers.

The optional 15-liter compressor cool box can be pulled out & removed & is powered by 12 V on-board power supply.

Opt. comfort cushion complements reclining surface of original 3-seater bench to form a bed. For even more comfortable reclining or if a multiflexboard cushion is not available in Multivan.



Dims. CampingBox LCM

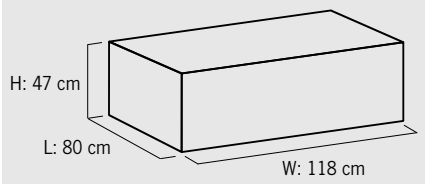

CAMPINGBOX WV

Suitable for Volkswagen T6.1/T6/T5 and Mercedes-Benz Vito from YOC. 8/2014, each with REIMO Weekender sleep/seat bench



Ideal travel companion for camping vacations or spontaneous short trips.

- Multifunction rear kitchen w/ clever storage system
- Easy installation without modifications to the vehicle
- Rear wall flap can be used as storage area
- High-quality HPL surface, Pearl Black decor
- Open tailgate protects even in the rain (optimally expandable with a rear tent)
- Side carrying handles for easy installation & removal



The multifunctional CampingBox WV is placed in the rear of the vehicle and screwed into the floor rails. The rear shelf of the bench seat is removed, the rear cushion of the Reimo V3000 bench then lies on the camping box and makes with the seat-sleeper bench a flat lying surface.

The height of the camping box WV is aligned to fit the REIMO Weekender bench seat for Mercedes-Benz Vito. For use with a REIMO Weekender bench in the Volkswagen, Renault or Ford Transit, a 30 mm thick additional pad is required to achieve a level lying surface.

Scope of delivery:

- Left two drawers with practical folding silicone sink and faucet
- In the center 2 removable plastic storage boxes with lids (size M, 18 l volume, dims.: 40x34x17 cm). Behind it, a water system w/ 10-liter fresh water canister & submersible pump.
- On the right, a pull-out for optional 28-liter CARBEST compressor cool box

CampingBox WV

Dims.: app. W 119.5 x H 43 x D 70/62 cm, decor: Pearl Black

13263 1199,-

Optional accessories:

CARBEST 28 L Compressor Cooler Box

71375 549,-

Gas cartridge stove, 1 flame

706474 64.99

Cutlery tray w/ 4 comp.

922582 3.99

Storage box with lid, size M 18, dims.: 40x34x17 cm

94915 9,-

Dust box with lid, size Cube, 27 l, dims.: 40x34x27 cm

94916 10.90



Multifunctional, extensively equipped and ready for use anywhere.

The CampingBox is the ideal camping module for short vacations, weekend trips and for active leisure fun.



Accessories shown are not included

Dims. CampingBox WV

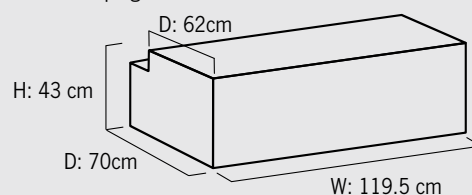

THE LUGGAGE BUTLER

Luggage drawer for convenient loading of the trunk



Easy and convenient loading / unloading of your vehicle with the bed built.

- Heavy duty full extension slides with a load cap. of 130 kg per pair
- Fastening covers all vehicle-specific rail spacings
- Mounting of the frame takes place in the floor rails
- Special rear extensions for Volkswagen California Coast/Beach/Ocean and Multivan



The rear extension makes it easier to load and unload your vehicle when the rear seat is converted to a bed. The rear extension utilizes the entire remaining trunk area.

The frame of the rear extension is securely connected to the vehicle at four points. Delivery pre-assembled.

Scope of delivery: Including assembly and fastening material, belt eyelets, pull-out rails, base plate and assembly instructions.

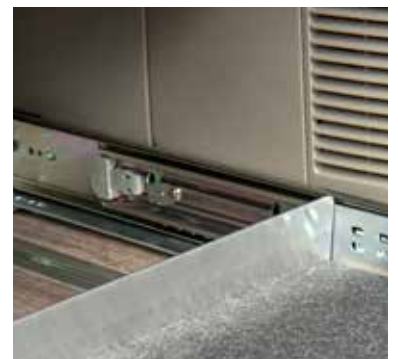

Vehicles	Outer dimension Width x length in mm	Footprint Width x length in mm	itemNo:	Price
Volkswagen Triostyle with canister	930 x 600	875 x 557	50512	479,-
Mercedes-Benz Triostyle Renault Triostyle Volkswagen Triostyle only furniture	1050 x 600	995 x 557	50513	489,-
Ford Triostyle Volkswagen Cityvan Volkswagen Weekender Plus	1170 x 600	1115 x 557	50514	499,-
Mercedes-Benz Cityvan and Weekender Renault Weekender Volkswagen Weekender	1220 x 600	1165 x 557	50515	499,-
Volkswagen California Beach, Multivan	1075 / 1200 x 750	1020 x 709	50519	499,-



**SELF
INSTALL**

SELBST EINBAUEN

▪ CONTENT ▪

COMFORT BEDS FOR VOLKSWAGEN & MERCEDES-BENZ	20-21
ADDITIONAL BEDS FOR CAB	22-23
KITCHEN MODULES CALICOOK + CALI CABINET	24-25
FLEX KITCHEN WITH GAS SYSTEM	26
MULTIFUNCTIONAL KITCHEN PART EASY-KITCHEN	27
MULTIFUNCTIONAL KITCHEN MODULES	28



REIMO VAN-CONCEPT

FURNITURE MODULES FOR MAKERS

Here you will find kitchen and cabinet modules for flexible camping and leisure. Expand your van with REIMO modules and turn it into a comfortable recreational vehicle with the comfort beds or additional beds for the driver's cab.

COMFORT BEDS INSTALLED QUICKLY AND EASILY

For Mercedes-Benz and Volkswagen Transporter, Multivan from 2003 & from 2022



- Aluminum frame w/ comfortable slatted frame suspension
- Comfortable maxi bed with a lying surface of 195 x 140 cm
- Luxury mattress 12 cm thick, with high quality Drell cover
- Clear height under the bed 33,5 cm (suitable e.g. for Porta Potti 335 Cube)
- Foldable for installation of original single seats
- Easy to install and remove without modification to the vehicle
- The bed is fixed in the original floor rails with quick clamps





① **Comfort bed for Mercedes-Benz Vito + V-Class:** Fits in VS20, length 5.14 m (Vito and V-Class) with the seat rail system. Two individual seats can remain in the vehicle. These are pushed all the way forward when bed is erected and placed in the transport position. Dims. comfort bed: LxW 194,5x140,5 cm. Dimension folded: 150x140 cm. Mattress thickness: 11.5 cm
93023 949,-

② **Comfort bed for Volkswagen Transporter 6.1/6/5:** The bed is attached to the seat rails of the Multivan or California Beach. For Transporter and Caravelle there are corresponding adapters to fix the bed in the lashing eyes. The seats must be removed for this purpose. Dims. comfort bed: LxW 194x148,5 cm. Dimension folded: 150x140 cm. Mattress thickness: 9.5 cm

Volkswagen Multivan/California Beach
930231 999,-

Adapter for Volkswagen Transporter/Caravelle
 attachment to lashing eyes **930232 89,-**

③ **Comfort bed for Volkswagen Multivan from YOC. 2022** The bed is for the vehicle with seat rail system. Two/three individual seats can remain in the vehicle, the backrest must be folded down. Rear section can be folded up for transporting bulky goods. Mattress app. 135x200 cm, mattress thickness app. 8 cm.
11710 949,-

Setup modules for the Volkswagen Multivan from 2022 can be found on page 44

Scope of delivery: Bed construction w/ slatted frame, comfort mattress & fastening material.



Comfort bed for Mercedes-Benz Vito + V-Class



Comfort bed for Volkswagen Multivan from 2022



ADDITIONAL BEDS FOR CAB



Patented cab bed system for cab swivel seats

- For additional sleeping places in driver's cab
- Easy assembly & disassembly in 30 sec.
- Very stable, each bed supports up to 70 kg
- Strong, wipeable Cordura fabric
- Compact pack size when not in use & storage
- Each child has its own sleeping place
- Lying surface: 174 x 55 cm
- Robust, double-walled telescopic aluminum rod
- Mounting kit for easy installation on sliding doors or swivel seats
- Weight: single bed 3.5 kg, double bed 7 kg



Attachment by hanging on the headrests

Attachment to supplied aluminum telescopic rods



NEW! Including mounting kit
*except for Volkswagen Transporter w/ double seat



	Volkswagen Caddy, VW T4/T5/T6, Mercedes-Benz Viano/Vito/Metris, Ford Transit Custom, Renault Trafic		Volkswagen Transporter w/ double seat*		Ford Transit < 2014		Renault Master/ Opel Movano < 21		Mercedes-Benz Sprinter, Volkswagen Crafter, Fiat Ducato, Peugeot Boxer, Ford Transit(> 2015)		3-fold seat all vehicles	
Single bed	42193	294,-	42188	245,-	42197	294,-	42195	294,-	42191	294,-	—	—
Double bed	42194	529,-	—	—	42198	529,-	42196	529,-	42192	529,-	42199	529,-

*For Volkswagen Transporter with double seat mounting kit please order separately. 42180 79,95

BED EXTENSION AND UPHOLSTERY MULTIVAN

- With Lazy Bed, together with original bench seat, you can "conjure up" a comfortable sleeping area in your Multivan in no time at all

① Extension Lazy Bed

The bed extension is anchored behind the seat bench in the slide rails. In everyday use, it can be used as a trunk cover. With metal support feet and 2 quick release fasteners. App. dims.: width 1284 x length in driving direction 564 x height 520 mm. Decor anthracite metallic.

11101 399,-

② Comfort cushion for Lazy Bed extension

This comfort cushion turns the "hilly" and hard bed landscape of your Multivan into a level, comfortable bed. The folded comfort cushion finds its place on the cover plate. Cushion dimensions: app. 135 x 190 cm. Cover microfiber fabric (100% polyester) gray. Foam about 5 cm thick.

11003 219,-



CAMPSLEEP - EXTRA BEDS FOR THE DRIVER'S CABIN



CampSleep

Additional bed for driver's cab in motorhomes such as Fiat Ducato or Mercedes-Benz Sprinter etc.

CampSleep is suitable as a comfortable additional bed for driver's cab in motorhomes (2-seater) from YOC. 2005 such as: Ducato / Sprinter / Transit / Crafter / Boxer / Master / Jumper / Daily. CampSleep is unfolded 2-fold. Total length from door to door about 160 cm. The depth to the glove box is about 74 cm, to the steering wheel about 44 cm. Dims.: L 160 x W 73 x H 10 cm. Pack size: L 81 x W 73 x H 20 cm. Weight app. 6.5 kg

42173 399,-

Protective bag for CampSleep extra bed (o. Fig.)

Protects against dirt and dust.

421731 35,95



CampSleep small

Additional bed for driver's cab in small commercial vehicles

CampSleep small, the comfortable extra bed for the driver's cabin of vehicles of the smaller commercial vehicle class, e.g. Volkswagen, Mercedes-Benz Vito, etc. The bed is folded up only 2 times. This makes it convenient to create another sleeping option on the seats in the driver's cab.

Dims.: L 148 x W 64 x H 10 cm. Pack size: L 75 x W 64 x H 20 cm.

Weight only about 6 kg.

42174 299,-



KITCHEN MODULE CALICOOK - Volkswagen T6.1/T6/T5

For Volkswagen T6.1/T6/T5 California Beach and Multivan



Equipment Calicook:

- Stainless steel sink with removable folding bowl insert
- Water system with submersible pump and shower tap with hose and 1 each fresh and waste water canister à 10 l
- Heavy-duty pull-out for optional 26-liter compressor cooler McCamping STYLE'N'COOL
- Drawer for dishes and cutlery with pull-out shelf

Dimensions: W 650 x H 785 x D 640 mm (table height 710 mm, carcass width 410 mm) Pearl wood decor **11120 2169,-**



Longitudinally sliding kitchen provides space for large drivers

Upgrade your Volkswagen California Beach or Multivan to a real camping bus with Calicook

- Practical kitchen part for installation behind driver's seat
- Can also remain in vehicle in sleeping position of bench seat
- Optimal place to eat for 2 people at the folding tables
- Sink with faucet
- Plenty of storage space, large drawer with room for a cool box
- The kitchen block can stay at home in everyday use



Kitchen part for installation transversely behind driver's seat of Volkswagen T6.1/T6/T5 California Beach & Multivan w/ original Volkswagen 3 bench. Body can be moved in Volkswagen floor rails in direction of travel.

Calicook offers a stainless steel sink with shower faucet & water system with a 10-liter fresh & waste water canister each, a pull-out for a large 26-liter compressor cooler (optional) and storage space.

The practical folding table and pull-out shelf turn the kitchen unit into a breakfast table for everyone. The clever splash guard protects upholstery of the driver's seat. Thanks to the longitudinal adjustment, every driver can sit comfortably and relaxed. Even with the kitchen section installed, the full bed length is available. Calicook can be left at home for everyday use as it can be removed in no time at all without tools. Of course, you can also use Calicook outside the vehicle (e.g. in the awning or under the awning).



Practical: the sink with faucet and sink bowl



Integrated fresh and waste water canisters

Pictured decorative material not included.

KITCHEN MODULE CAL CABINET - Volkswagen T6.1/T6/T5

For Volkswagen T6.1/T6 /T5 California Beach and Multivan



Plenty of storage space & work surface w/ kitchen module CaliCabinet

- The perfect set-up module for Volkswagen T6.1/T6/T5 California Beach and Multivan SWB and LWB*
- Sliding and removable
- Installation without tools and modification to the vehicle
- Fits even with bench in sleeping position
- Plenty of storage space, large drawer with room for a cool box
- The kitchen cabinet can stay at home in everyday use

*each with 3-seater Volkswagen bench, 1 or 2 sliding doors. To be mounted in Volkswagen rails behind the driver's seat, sliding for more space on driver's seat.



Cooler drawer for Calicook and CaliCabinet



Even in sleeping position, the kitchen can remain.

The CaliCabinet furnishing module offers versatile equipment. Folding table attached in the direction of the bench serves as a dining or work table.

Above the lockable pull-out for a large 26-liter compressor cooler (optional) is a drawer for cutlery and other utensils, complemented by a pull-out shelf for additional work surface or storage.

The top storage compartment with shelf offers enough space for lots of dishes and supplies.

Longitudinal adjustability allows each driver to sit comfortably and relaxed. Even with kitchen section installed, the full bed length is available.

The CaliCabinet can be removed in no time without tools and can also be used in the awning or under the awning.



In the large drawer also fits the cooler.

Equipment CaliCabinet:

- Folding table
- Heavy duty drawer for optional McCamping STYLE'N'COOL compressor cooler
- Drawer for dishes and cutlery with pull-out shelf

Dims.: W 635 x H 1210 x D 665 mm (table height 710 mm, carcass width 410 mm) Pearl wood decor **11121 1999,-**

Accessories for CaliCook and CaliCabinet:

26 l compressor cooler

McCamping
STYLE'N'COOL
714491 279,-

Cartridge stove Camp Bistro DLX

With Safety Lock System and piezo ignition.
Power: 2200 W,
Dims.: W37xD28xH12 cm,
weight: app. 1,9kg
706474 64,99



Pictured decorative material not included.

MULTIFUNCTIONAL FLEX KITCHEN WITH GAS SYSTEM

For Volkswagen T6.1/T6/T5 station wagon, short or long wheelbase



- Removable & (opt.) swiveling kitchen section for installation behind front passenger seat
- With 1-burner stove-sink combination for 2.8 kg gas bottle
- Convenient cooking outside the vehicle
- No odor nuisance in the interior
- Plenty of storage space, large drawer
- The kitchen block can stay at home in everyday use

Various application possibilities:

- Fixed in the vehicle in REIMO floor rails
- Swiveled outward on the passenger side (swiveling system optional)
- Set up separately for outdoor cooking

Removable kitchen part for installation behind the passenger seat in Volkswagen T6.1/T6/T5 Kombi/Caravelle (not suitable for Multivan and California Beach). In combination with a REIMO sleeping bench V3000 the full bed length can be used. Installation in vehicle possible according to EU & German registration regulations. Registration of vehicle as a motorhome (in conjunction with sleeping bench). For operation in the vehicle, gas box venting through the vehicle floor is mandatory.

Equipment:

- ① Cooker-sink combination with glass cover
Fixed 1-burner gas stove, stainless steel sink with tap Ø 240 mm, depth 125 mm
- ② 2 side folding tables 388 x 295 mm
- ③ 1 drawer for cutlery & dishes, 1 storage compartment for small items
- ④ 1 clip-on shelf 350 x 260 mm
- ⑤ 2 handles for easier lifting
- ⑥ Water system w/ submersible pump (connection to 12 V socket) & one 10 l fresh & one 10 l waste water canister each
- ⑦ Integrated gas box for a 2.8 -kg Campingaz gas bottle

Kitchen part pre-assembled with built-in technology and fastening material for Reimo floor rails. Without swivel unit, please order separately.

Overall dims.: W 595 mm (tables folded down) x H 730 x D 450 mm (plus canister 75 mm)

Furniture decor: Installation in direction of travel

right high gloss white	11110	2299,-
High gloss silver	11110S	2229,-
Matte black	11110B	2399,-

Optional accessories: Flex kitchen swivel unit for Volkswagen For installation on B-pillar on passenger side (with suitable tools)

11114	499,-
-------	-------



Pivot system for passenger side optionally available.



MULTIFUNCTIONAL EASY KITCHEN

For Volkswagen T6.1/T6/T5 station wagon SWB or LWB & Mercedes-Benz Vito long station wagon



For installation behind the passenger seat in the Mercedes-Benz Vito. In combination with a REIMO sleeping bench V3000 the full bed length can be used.



Flexible kitchen part

- Removable kitchen section for installation behind the driver or passenger seat
- Outswiveling with optional swivel fitting
- With stainless steel sink & water system
- Convenient cooking outside the vehicle
- No odor nuisance in the interior
- Plenty of storage space, large drawer
- The kitchen block can stay at home in everyday use

Kitchen part for installation right/left behind driver's cab seats in Volkswagen T6.1/T6/T5 Kombi/Caravelle in combination with a Reimo sleeping bench V3000 (not suitable for Multivan and California Beach).

Various application possibilities:

- In the vehicle, fixed in REIMO floor rails
- Swiveled outward (optional)
- Separate for outdoor cooking or awning

Equipment:

- ① Stainless steel sink
- ② Pull out faucet with shower hose
- ③ Water system w/ submersible pump (connection to 12 V socket) & one 10 l fresh & one 10 l waste water canister each
- ④ 1 drawer for cutlery and dishes
- ⑤ 1 storage compartment for pots & dishes
- ⑥ Storage compartment for gas cartridge stove
- ⑦ 2 side folding tables 388 x 295 mm
- ⑧ 2 handles for easier lifting

Kitchen part pre-assembled with built-in technology, including fastening material for Reimo floor rails.

Overall dims.: W 595 mm (tables folded down) x H 730 mm x D 450 mm (plus canister 76 mm)

Furniture decor: High gloss white

for mounting right	11112	1929,-
for mounting left	11113	1999,-

High gloss silver		
for mounting right	11112S	1929,-
for mounting left	11113S	1999,-

Matte black		
for mounting right	11112B	1999,-
for mounting left	11113B	2099,-

⑨ Suitable swivel unit for kitchen Easy

For installation on B-pillar (with suitable tool) for Volkswagen Mounting on right side

	11114	499,-
for Volkswagen mounting left		

	11115	499,-
for Mercedes-Benz Vito (only possible with Easy)	571112	499,-

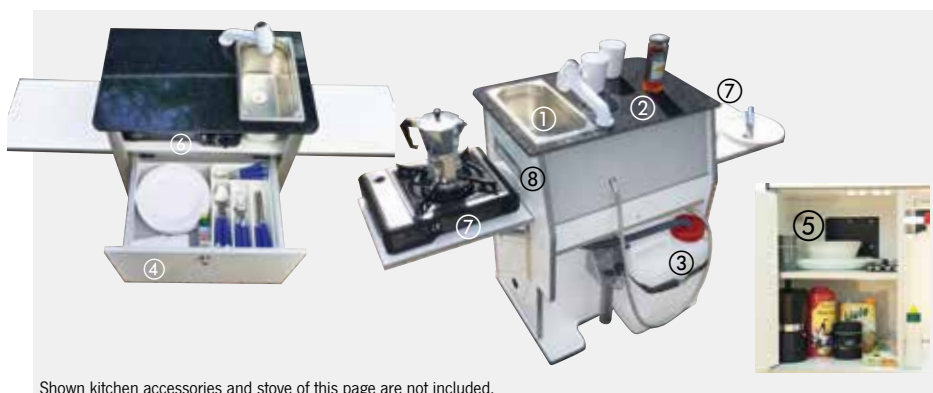

Shown kitchen accessories and stove of this page are not included.

MULTIFUNCTIONAL KITCHEN MODULES PANTRY

For Volkswagen Transporter 6.1/6/5, Renault, Opel, Fiat, Nissan



- With these multifunctional kitchen modules you can quickly and easily transform your Volkswagen Multivan, California Beach or Weekender into a practical and comfortable camper
- Complete basic camping equipment already integrated
- Noble furniture construction w/ distinctive rounded aluminum edges
- Mounting of the kitchen part in the original seat mounting rails
- Plenty of storage space, large drawer

Suitable for installation in the following vehicles:

- Volkswagen Transporter 6.1/6/5 Multivan & California BeachCombi short or long wheelbase
- Reimo Weekender based on: Volkswagen T6.1/T6//T5 Renault Trafic Opel Vivaro B Kombi Fiat Talento Nissan NV300 from YOC. 7/2014



①

With complete camping basic equipment. 2x 12-liter canisters for fresh and waste water are located in the rear part of the kitchen section and are hidden by the backrest of the driver's cab seat.

Each pantry kitchen part is equipped with a drawer and a spacious storage compartment. A folding table can be mounted either on the right or left, so the kitchen parts can be used on the driver's or passenger's side.

Noble furniture construction with distinctive rounded aluminum edges in front. Mounting in the original seat mounting rails. Kitchen part fits exactly between the front edge of the bench seat (converted into a bed) and the front seats. Dims.: H73 x W65 x D48.5 cm. With sink, glass cover and technology. Installed ready for connection with 12 V plug. (weight app. 35 kg).

Furniture decor:

- | | | |
|-----------------------|----------------|---------------|
| ① Anthracite metallic | 11100T | 1499,- |
| ② High gloss black | 11100TB | 1499,- |
| ③ High gloss white | 11100TW | 1499,- |
| ④ High gloss silver | 11100TS | 1499,- |



②



(Stove not included)

Furniture decor:

- | | | |
|---------------------|----------------|---------------|
| ③ High gloss white | 11100TW | 1499,- |
| ④ High gloss silver | 11100TS | 1499,- |



③



(pot and stove not included)



Cartridge stove Camp Bistro DLX With safety lock system and piezo ignition. Power: 2200 W, Dims.: W37xD28xH12 cm, Weight: app. 1,9kg



706474 64,99

XXXXXXXXXX





-CONTENT-

CAMP 2 FOR VOLKSWAGEN CADDY 5 MAXI	32-33
CAMP FOR VOLKSWAGEN CADDY 4 MAXI	34-35
WEEKENDER 2 FOR VOLKSWAGEN CADDY 5 MAXI.....	36-37
 WEEKENDER FOR VOLKSWAGEN CADDY 4 MAXI.....	38-39
 ACTIVE FOR VOLKSWAGEN CADDY	40-41



REIMO VAN-CONCEPT

REIMO MINICAMPER

The complete camping equipment for vacation and leisure in a minivan.
Despite camping equipment on board, you can use your vehicle to the full extent of everyday life.
Thus, nothing stands in the way of your individual use.



VOLKSWAGEN CADDY / FORD CONNECT - C

Based on Volkswagen Caddy 5 Maxi (long wheelbase) YOC. from 5/2020
& Ford Connect (long wheelbase) YOC. from 2023 onwards

NEW

Mini camper with maxi benefit

- Fully-fledged camper w/ compact furniture line
- Living area with 3-4 seats and folding table
- Standing height in living area with sleeping roof up
- Full suitability for everyday use thanks to 5 standard seats & load variability

The elegant furniture line offers a full mini kitchen with high quality countertop, stainless steel sink and faucet with additional outdoor shower function. Including fresh and waste water supply, high-quality 39-liter compressor refrigerator and optional induction or gas cartridge stove (option).

For the overnight stay there is a bed available, which scores with a variable sleeping surface. Single bed with aisle: 195x70/87 cm, wide bed: 195x96/132 cm. It can be folded up, should you want to transport bicycles, for example. For even larger transport tasks, the left expansion part (bed + electrical corpus) can be removed in a few easy steps.



Driving and travel

- The 5 original seats with three-point belts remain fully intact.

Sleep

- Level, comfortable bed with comfort cushions. Single bed with aisle: 195x70 cm Wide bed: 195x96/132 cm

Living

- Entry through side sliding door
- 3-4 seats in the living area
- Full kitchen block
- Movable table
- Kitchen w/ stainless steel sink, 230 V induction stove, water tap w/ outdoor shower function, fresh & waste water supply, 39-liter compressor refrigerator

Loading and storage space

- Variable cargo space size due to fold-up bed & fold-down bench seat
- Optional storage box w/ plenty of space
- Large storage space in rear of vehicle
- Bed and carcass left side completely removable, e.g. for bicycle transport (dims. max.: LxH 230x96 cm)

Onboard electrics (optional)

- 12 V system w/ 60 Ah secondary battery
- 230 V system incl. charger (optional)



Technical specifications

Sleeps on couchette: 1-2 Light bed dimension
LWB: 195x96/132 cm
bench: Original Volkswagen
Seats with three-point seat belts:

max.5

Living bench for 2 persons in the rear
Kitchen unit with sink and folding shelf
Fresh/Wastewater: 13/13 liters
Compressor refrigerator CRF 40: app. 39 liters
Interior trim original Volkswagen Caddy
Base plate in rear of vehicle to accommodate
Furniture line & bed

Variable cargo space size due to fold-up bed &
fold-down bench
Optional storage box w/ plenty of space e.g. for
Porta Potti (in exchange for single seat in 2nd row.
Series) 13507. Optional large storage box (in
exchange for 2-seat bench) 13505.

Base vehicle:

Suitable for Volkswagen Caddy Maxi, Life, Style
with Volkswagen cladding

Sizes (LxWxH): 4,85 m x 1,85 m x 1,80 m

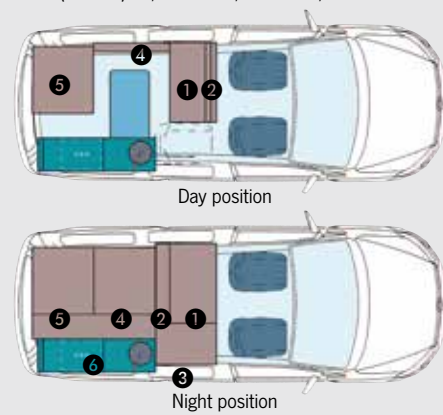

VanHeat 2.0-DH

Diesel parking heater CARBEST VanHeat 2.0-DH 2 kW power, integrated alt. adj. up to 5,000 m, type approval according to UN ECE R122, app. by Federal Motor Transport Authority according to UN ECE R10, incl. LCD control panel, tank removal set & extensive installation material.

48182 649,-

Underfloor mounting kit for parking heater VanHeat 2.0-DH Diesel. Underfloor mounting kit is installed in middle of vehicle in conjunction with parking heater VanHeat 2.0-DH Diesel between sliding doors as well as wheel housings. Scope of delivery: Silencer, underfloor installation box, voltage transformer 12 V DC 1203 & mounting material.

14505 332,40

Petrol parking heater Webasto Air Top 2000 STC-B
480892 1199,-



Camp furniture line as a finished part White high gloss furniture line w/ drawer & storage compartments, pre-assembled. Prepared for the installation of the compressor refrigerator, sink with canister, water system and technology.

14501 1590,-



Tech. package installed in above furniture line Tech. package consists of: 39-l- compressor refrigerator CRF 40, water system w/ 2x 13-liter water canisters for fresh & waste water, 230 V built-in socket, USB charging socket, neon signal light, 230 V induction hotplate

14501TE 2490,-



Camp bed with folding bench High gloss white. Includes following upholstery parts: ① ② ④ ⑤ ⑥ Upholstery: Titanium Black. Use only possible in conjunction with Camp furniture line. Sleeping surface 195x96 cm.

14502 1390,-



Technology package partially installed in bed box 12 V & 230 V system, switch-mode charger 20 A, AGM battery with 60 Ah capacity, charge booster (WA 121525). CEE body socket, voltmeter, universal socket, 13 A circuit breaker w/ RCD, 230 V built-in socket, power socket up to max. 20 A, USB built-in socket, 50 A fuse holder (CEE socket and power connections must be installed in vehicle)

14502TE 1390,-

Camp base plate, Decor Ticino
14500 169,-



Camp table system Including table base and table slide. Table top 70x44 cm, decor Pearl, Anthracite

14503 169,-



Dust box for portable toilet

The stowage box is used instead of the single seat on the passenger side. It offers space for the Porta Potti 335 Cube. Or for other utensils such as shoes, tools, etc. Tool-free exchangeable for removable single seat. (Toilet optional) Dims.: L 63 x W 42.5 x 35 cm.

13507 429,-

Upholstered pad on table top or for above storage box To widen the sleeping surface from the furniture line to 132 cm (upholstered part ③)

135070 159,-



Camp storage box (opt.) for Caddy SWB and Maxi from YOC. Sept. 2010. Is used instead of the original 2-seater bench seat under folding bench seat w/ cushion from item no. 14502 without tools. Dims.: L 51 x W 85 x H 33 cm.

13505 539,-

VOLKSWAGEN CADDY MAXI - CAMP

Based on Volkswagen Caddy 3/4 Maxi (long wheelbase) YOC. 8/2008 to 8/2020

Mini camper with complete equipment

- Fully-fledged 5-seater despite built-in furniture line
- With complete camping equipment for vacation & everyday life
- Generous storage space

Perfect companion on vacation & in everyday life. Despite camping equipment, the Camp can be used as a full 5-seater in everyday life & offers extremely generous storage space. At the same time, camping equipment remains on board without interfering w/ everyday use.

With a compact overall height of only about 1.96 m with sleeping roof mounted (opt.), it fits into almost all parking garages & is allowed inside where other camping buses have to "stay outside". Visit dreamlike campsites with your camp and enjoy your vacation with the whole family with the sleeping roof folded up (optional).



Driving and travel

- The 5 original Caddy seats with three-point seat belts remain fully intact.

Sleep

- Level, comfortable bed with comfort cushions and spacious sleeping areas. Single bed with aisle: 200x70 cm or wide bed without aisle: 200x113/132 cm

Living

- Entry through side sliding door
- Living bench for 2 persons + 3. Rear seat
- Kitchen block w/ sink, water system, stove, 18-liter compressor cooler & folding tray
- Movable table

Loading and storage space

- Variable cargo space size due to fold-up bed and fold-down bench. Loading space max.: 230x113 cm
- Optional storage box w/ plenty of space
- Large storage space in rear of vehicle. Conveniently holds all vacation luggage



Technical specifications

Sleeps on couchette: 2 Light bed size
 LWB: 200 x 113 / 132 cm
 bench seat: Original Volkswagen
 Seats with three-point seat belts: 5

Living bench for 2 persons in the rear
 Kitchen block with sink
 Fresh/waste water 2 x 13 liters
 CoolFreeze CDF 18 cooler app. 18 liters
 Interior trim original Volkswagen Caddy
 Base plate in rear of vehicle to accommodate
 Furniture unit, storage box & bed/folding seat
 bench

Variable cargo space size due to fold-up bed and
 fold-down bench seat
 Optional storage box with plenty of space e.g. for
 Porta Potti (original rear seat is then removed)

Original Caddy 12 V system with interior lighting
 2. Battery 60 Ah

Base vehicle:

Suitable for Volkswagen Caddy 3/4 Maxi
 Trendline, Comfortline and Highline with original
 plastic trim.

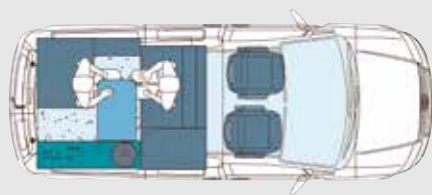

Day position 135070

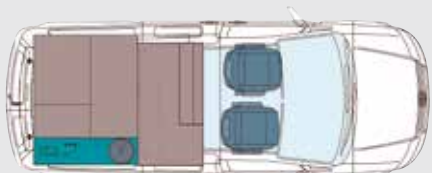

Night position 135070



Camp furniture line High Gloss White Incl. mounted technology, consisting of: 12 V system w/ 60 Ah Green Power battery, Reimo safety panel 714; LED line light Mini 12 V, canister water system with 2x 13 liters, stainless steel sink round, cooler CoolFreeze CDF 18. For Caddy Maxi station wagon without molded headliner

13501T 4360,-

For Caddy Maxi estate Trendline, Comfortline & Highline w/ molded headlining

135011T 4115,-

230 volt system mounted in furniture line

Carbest switch-mode charger 10 A, circuit breaker 13 A with FI, signal lamp 230 V. 230 V built-in socket with frame. With CEE socket including cable for laying and connection in the vehicle (self-installation).

135011TE 549,-



Camp bed with folding bench High gloss white. Includes 5 upholstered parts for bed and folding bench. (Please order cushion for table top/Porta Potti box art. no.: 135070 separately). Upholstery: Titanium Black. Use only possible in conjunction with Camp furniture line. Sleeping surface 200x113 cm.

13502 1399,-

Camp bottom panel, Decor ship bottom
13500 259,-



Camp storage box (optional) for Caddy SWB & Maxi LWB from YOC. Sept. 2010. Can be used for expansion Camp and Active. Tool-free exchangeable against removable original 2-seater bench in 2. Row of seats. Additional storage volume 115 liters. Can be used with & without expansion. Dims.: L 51 x W 85 x H 33 cm.

13505 539,-



Dust box for portable toilet

The stowage box is used instead of the single seat on the passenger side. It offers space for the Porta Potti 335 Cube (optional). Or for other utensils such as shoes, tools, etc. Tool-less exchangeable against removable single seat. Dims.: L 63 x W 42.5 x 35 cm.

13507 429,-

Porta Potti 335 Cube **660102 149,-**

Cushion pad

For table top or for storage box 13507. To widen the sleeping area from the furniture line to 132 cm.

135070 159,-



Camp table system Table top: 70x44 cm. incl. table base + table glides decor Pearl, Anthracite
14503 169,-



Installation box white for parking heater VanHeat 2.0-DH, as a finished part.

13506 269,-



VanHeat 2.0-DH

Diesel parking heater CARBEST VanHeat 2.0-DH 2 kW power, integrated alt. adj. up to 5,000 m, type approval according to UN ECE R122, app. by Federal Motor Transport Authority according to UN ECE R10, incl. LCD control panel, tank removal set & extensive installation material.

48182 649,-

230 V induction cooker

70443 57,95



VOLKSWAGEN CADDY / FORD CONNECT - WEEKENDER 2

Based on Volkswagen Caddy 5 Maxi (long wheelbase) YOC. from 5/2020 or Ford Connect (long wheelbase) YOC. from 2023



Mini camper to retrofit yourself.

- Ingeniously compact kitchen box with sink, water system, gas stove & space for optional compressor cooler
- No modifications need to be made to the vehicle for installation
- Fits every Caddy 5 Maxi (LWB) from YOC. 05.2020 and Ford Connect (LWB) from YOC. 2023
- Comfortable living situation for 3 to 4 people
- Two sleeping options: Can be used with a single bed or double bed
- Optionally w/ sleeping roof



Seating group and living area With the folding bench and seating opposite, this makes a cozy 2-4 person seating area.

Entry through sliding door is possible on the right or left side. Standing height is achieved with optional sleeping roof. The hook-in table serves as a padding base when building the bed.



The new "Weekender 2" extension is modular and can be retrofitted to any Caddy 5 Maxi 5-seater and Ford Tourneo Connect 3 long wheelbase without modification to the vehicle. The large bed area is highly variable: either as a single bed with a lying surface of 195 x 70/87 cm, then there is still space next to it for e.g. the bicycle. Or additionally with large kitchen box incl. cushion (14601), which increases the bed area to 195 x 116/132 cm. The kitchen box includes a water system including a folding sink, a gas cartridge stove and space for an optional compressor cooler.

This equipment can be pulled out of the tailgate opening in a pull-out to the rear and is convenient to operate from inside and outside.

The table also makes it possible to configure a cozy living situation with 3-4 seats. Furniture modules and bench seat are removable for transporting large luggage. A loading volume of approx. 2.5 m³ is then available.

Technical specifications

Sleeps on couchette: 2 Light bed size
 LWB:
 Single bed: 195x70/87 cm
 Double bed 195x116/132 cm
 Bench: Original Volkswagen
 Seats with three-point seat belts: max. 5
 Living bench for 2 persons in the rear
 Kitchen unit with folding sink
 Fresh/waste water 10/10 liters
 Compressor cooler approx. 10 L
 Interior trim original VOLKSWAGEN Caddy
 Base plate in rear of vehicle to accommodate
 Bed carcass and kitchen unit
 Variable cargo space size due to fold-up bed and
 bench seat
 Optional large storage box to exchange for
 original back seat Optional storage box for mobile
 camping toilet Porta Potti 335 Cube in exchange
 for single bed
 Vehicle Electrics:
 Original Caddy 12 V system with interior lighting,
 2. Battery system optional

Base vehicle:

Suitable for VOLKSWAGEN Caddy Maxi, Life, Style
 with original plastic trim.
 Sizes (LxWxH): 4,85 m x 1,85 m x 1,80 m

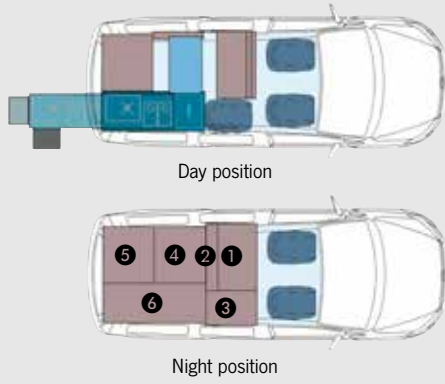

Technical package partially installed in bed box
 12V and 230V system, switch-mode charger 20A, AGM
 battery w/ 60Ah power, charge booster (WA 121525).
 CEE surface-mounted socket, voltmeter, universal
 socket, 13A circuit breaker with RCD, 230V built-in
 socket, power socket up to max. 20A, USB built-in
 socket, 50A fuse holder. (The CEE sockets and power
 connections to the booster must be installed in the
 vehicle)

14502TE 1390,-



Bed with folding bench seat The single bed
 consists of a left folding part and the folding
 bench seat, which is positioned on the
 Volkswagen 2 seat. Sleeping surface of single
 bed: 195x70/87 cm. Next to it remains a lot of
 space, e.g. for sports equipment. The single bed
 can be extended to a double bed by the kitchen
 box. The cushion on the kitchen box increases
 the sleeping area to 195x116 cm or 132 cm with
 the cushion in front. All parts can remain
 installed even with 5 people on board. Includes
 following upholstery parts: ❶ ❷ ❸ ❹ ❺

14602 1499,-



Kitchen box The kitchen box is extendable over
 rear of vehicle. This allows convenient cooking
 outside the vehicle. The kitchen box is equipped
 with two 10-liter canisters, a gas cartridge stove
 and a folding sink. A cooler can optionally be
 placed in the front, fixed area of the kitchen box.
 The kitchen box extends the sleeping width of the
 bed to the entire interior width (195x116 cm).
 Includes following upholstery part: ❻

14601 1590,-

Weekender bottom panel, Décor Ticino

14500 169,-



Camp table system The table top is stowed on
 the back of the single seat where it serves as a
 bed rest. Incl. Table base and table glide rails.
 Table top: 70x44 cm, Pearl decor, anthracite.

14503 169,-



Camp storage box (opt.) for Caddy SWB &
 Maxi LWB from YOC. Sept. 2010. Is used instead
 of the original 2-seater bench seat under folding
 bench seat w/ cushion from item no. 14502
 without tools. Dims.: L 51 x W 85 x H 33 cm.

13505 539,-



Dust box for portable toilet

The storage box is used instead of the single
 seat on the passenger side. It offers space for the
 Porta Potti 335 Cube. Or for other utensils such
 as shoes, tools, etc. Tool-free exchangeable for
 removable single seat. (Toilet optional) Dims.: L
 63 x W 42.5 x 35 cm.

13507 429,-

Cushion pad for above storage box/table

Needed on the table top or for the double bed.
 Can be used in combination with the storage box
 13507, alternatively with the table system (if
 storage box is not available). To widen the
 sleeping area in front of the kitchen box to 132
 cm. Upholstery part: ❸

135070 159,-



Compressor cooler Cool'n'Heat for kitchen box

The 10 l compressor cooler with 2 functions:
 Cooling and heating. Operation via LCD touch
 display. With sturdy handle and 12/24V
 connection cable. Weight app. 8 kg.

713545 299,-

Porta Potti 335 Cube **660102 149,-**

REIMO WEEKENDER - VOLKSWAGEN CADDY

Based on Volkswagen Caddy 3/4 Maxi long wheelbase, YOC. 8/2008 to 8/2020



Nimble. Compact. Flexible.

The Volkswagen Caddy Weekender adapts perfectly to your needs. In everyday use, it is a full 5-seater. At weekends or on vacation, the flat XXL double bed can be used. This can also be configured as a single bed on one side. The bed can be folded up on both sides for maximum loading volume (e.g. for bicycles). Optionally, you can get a 12 V system with interior lighting. Further equipment options, such as a sleeping roof (cannot be installed yourself) for more sleeping space and headroom, give you a lot of design freedom!

- Mini camper with variable camping equipment
- For Volkswagen Caddy Maxi LWB YOC. 8/2008 - 8/2020
- Small and maneuverable - ideal for city traffic
- 2 sleeping options: Can be used with a single bed or double bed
- Optionally w/ sleeping roof
- Comfortable 2 - 4 person seating area with table
- Porta Potti accommodation
- High sleeping comfort thanks to flat sleeping surface
- All 5 original driving seats are retained



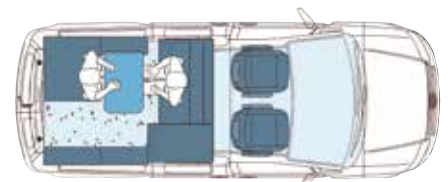

Long, day position

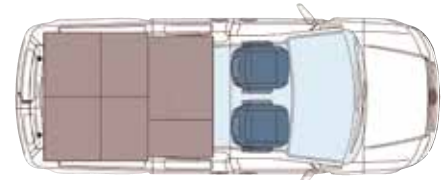

Long, night position



Sleep

The fold-up, comfortable rear bed for the Volkswagen Caddy Maxi LWB (YOC. 8/2010 - 8/2020) goes across entire interior width of vehicle. It offers a sleeping surface as a single bed of about 200x70 cm and as a double bed of about 200x145 cm. 2-person bed area can be divided in the middle. Used as a single bed, there is still plenty of space next to it, e.g. for sports equipment. The fold-up bed can remain installed for everyday use, even for larger transport tasks or with 5 people on board.

Rear bed w/ folding bench seat, incl. 7-piece cushion set
13602 2399,-

Living

With the folding bench and seating opposite, it makes a cozy 2-4 person seating area. Entry through the sliding door is possible on the right or left. Standing height is achieved with optional sleeping roof. For high flexibility, a table top can be mounted either on the right or left side.

Table system incl. table base and table slide rails. Table top app. 70 x 44 cm, Pearl decor, anthracite color.

13503 249,-
Base plate 13500 259,-

Loading and storage space

The bed folds up on both sides to create maximum cargo volume (bicycle, etc.), also remains a storage space under the bed level. Max. rear storage space w/ equipment installed: app. 2.4 m³

Optionally available:

- Large storage box for replacement w/ Volkswagen 2 bench for more storage space of 115 liters.
Dims.: app. L 51 x W 85 x 33 cm
13505 539,-

- Box for Porta Potti 335 Cube camping toilet to replace Volkswagen single seat behind passenger.
Dims.: L 63 x W 42 x 35 cm

Dust box for portable toilet
13507 429,-

Porta Potti 335 Cube
660102 149,-

Onboard technology

Standard with original Caddy 12 V system and interior lighting

Optionally available:

- **230 V system installed**
Carbest switch-mode charger 15 A, circuit breaker 13 A with RCD, 230 V signal light. 230 V built-in socket with frame. With CEE socket including cable for laying and connection in the vehicle (self-installation).

135011TE 549,-

- **CARBEST VanHeat 2.0-DH diesel parking heater** 2 kW output, integrated alt. adj. up to 5,000 m, type approval in accordance with UN ECE R122, approval by German Federal Motor Transport Authority in acc. w/ UN ECE R10, incl. LCD control panel, refueling kit & extensive installation mat.

48182 649,-

REIMO ACTIVE - VW CADDY & OTHER HIGH ROOF STATION WAGONS

Based on VW Caddy 3/4 Life / Trendline / Comfortline / Highline / Maxi



Minicamper De Luxe.

- Compact camping equipment
- Extendable kitchen module
- Slatted bed for 2 persons
- Removable dust box
- Sitting in rear of vehicle

The Active camping equipment - perfect camping equipment for recreational and everyday vehicles. Consisting of 4 modules: base plate, collapsible bed, kitchen box with 1 stainless steel sink and Water system (12 l fresh water / 5 l waste water), shower head w/ hose, compartment for stove as well as storage comp. for cookware and cutlery. Storage box with 60 l vol.



Extendable kitchen module for use in or in front of the vehicle. The removable cushion pad quickly transforms the kitchen module into a comfortable seat box. The 60-l storage box incl. seat cushion (opposite the kitchen box) is accessible from above & from the side. It can also be used outdoors as a seat.

Compact and functional

The compact extension with camping equipment. Ideal for your everyday vehicle.

Sitting in rear of vehicle

The upholstered cushions transform the kitchen module and the storage box into seat

Storage space in front of bench

Even with bed set up, there is still storage space available in front of bench.



Short wheelbase YOC 2003 until 8/2020 and long wheelbase YOC. 2008 until 8/2020

Technical specifications

Sleeps on sleeping/seating bench: 2
 Light bed measure: 195 x 120/130 cm bench:
 Original Volkswagen
 Seats with three-point seat belts: 5
 Cooling unit: Space for cooler in trunk
 furniture construction: Poplar plywood
 with HPL laminate fresh water / waste water:
 1x 12 l / 1x 5 l
 Storage space between kitchen box & storage
 box: app. 80 x 35 x 43 cm

Payload example:

Basic vehicle Volkswagen Caddy SWB Trendline,
 engine: 1.2 l petrol

Total permissible mass: 2165 kg
 Payload: app. 715 kg

Base vehicle:

VW Caddy (short WB, without sleeping roof) or
 VW Caddy Maxi (long WB, sleeping roof
 optional)

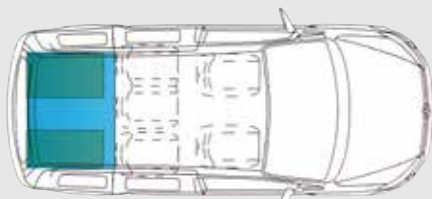

Day position

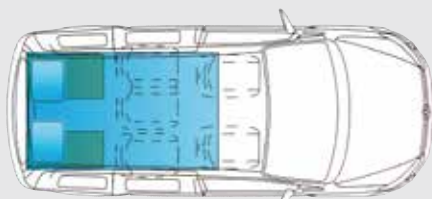

Night position



More info
 to the vehicle



Active equipment is also available for
 Citroën Berlingo II Multispace, Peugeot
 Partner II Tepee, Renault Kangoo II,
 Mercedes-Benz Citan and Ford
 Tourneo Connect SWB. All information
 available from your dealer or at [www.
 reimo.com](http://www.reimo.com)



Active base plate

For vehicles from YOC. 10/2003.
 Mandatory for the installation of all modules
 Assembly without tools. Decor Granitto.

short wheelbase 13204 349,-
long wheelbase 132040 309,-



Active bed caddy with cushion

Including anodized aluminum tube frame and

Cushion set, gray. Sleeping surface 195x
 120/130 cm

short wheelbase 13205 1429,-
long wheelbase 132050 1549,-



Kitchen box including water system

Assembly without tools, dims. 77 x 42 x 41.5
 cm white/olive decor.

13206 1699,-



Seat / dust box 60 l

For all REIMO Minicamper short and long
 wheelbase. Assembly without tools, dims. 77 x
 28 x 41.5 cm white/olive decor.

13207 1050,-



Portable camping toilet Porta Potti 335

Suitable for rear storage space between furniture
 line. High quality plastic for maximum hygiene.

660102 149,-



Thermal mats 3-piece, for driver's cab, from
 YOC. 2004

37226 59,95

Thermal mats 8-piece, Complete set, from YOC.
 2004

37227 157,95



Cooler box CC 8L Cooling cap.: -15°C to 20°C
 Dims. W x D x H: app. 190 x 538 x 390 mm
 Weight: app. 8.6 kg. Connection: 12/24 V Power
 consumption app. 35 watts

713543 349,-



Mobile shower w/ 20-l wide-neck canister incl.
 submersible pump.

64132 89,60

REIMO VAN-CONCEPT

VOLKSWAGEN CAMPINGVANS





Camping bus equipment for Volkswagen models - stylish & elegant.

Discover the complete REIMO Van-Concept interior range for T7/T6.1/T6/T5. From the functional furnishings to the exclusive kitchenette to the classic camper conversion for Volkswagen T3.



▪ CONTENT ▪

BASE Volkswagen Transporter 7/6.1/6/5

 FREEVAN	44-45
TRIOSTYLE	46-49
 SPORTCAMPER	50-53
 TRAVELSTYLE	54-57
CITYVAN	58-61
WEEKENDER PLUS	62-65
WEEKENDER	66-67
 MULTIFUNCTIONAL KITCHEN PARTS	68-69
 BIKE`N`SURF	70-71

BASE Volkswagen Transporter 3

 FLORIDA	72
 SPEEDY.....	73
 JOLLY	74



REIMO FREEVAN - VOLKSWAGEN T7

Based on Volkswagen Transporter 7 Multivan, length L2

NEW

Camping freedom experienced.

- Removable kitchen unit with water system and compressor cooler
- Table system can be used in the vehicle and with optional tripod frame also outside the vehicle
- Large comfort bed for high sleeping comfort
- Seat/sleeper bench with integrated seat belts and headrests
- Maximum 7 seats (with extended camping equipment)



Technical specifications

Vehicle dims.:	LxWxH: 517x190x197 cm
Sleeps on comfort bed:	2
Light bed measure:	210x137 cm single seats: max. 7
Seats with 3-point seat belts (with camping equipment installed):	4
Seats with three-point seat belts (with camping equipment removed):	7
Stove:	1 Flame Gas Cartridge Stove
Cooling unit:	Compressor cooler (37 l)*
Furniture construction:	Poplar plywood Pearl, Black Metallic
Fresh water / waste water:	1x 12-liter canister / 1x 12-liter canister*

*Included in the technology package

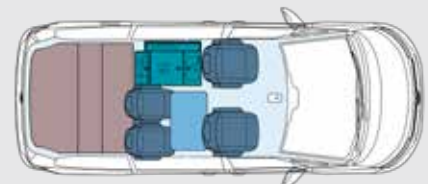

Day position

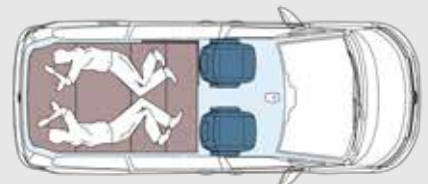

Night position



Furniture decor Pearl



Comfort bed w/ slatted frame & a sleeping surface of 210x137 cm offers highest sleeping comfort on the road, kitchen module must be ordered.
The storage space under the bed offers plenty of room for all the vacation luggage.





Comfort bed for Volkswagen T7

The bed is mounted in the original VW T7 floor rail. The rear seats must be removed when installing the bed. Individual seats in the sliding door area remain in the vehicle and are folded down to build the bed. The front part of the bed extends over the single seats and is supported by 2 folding feet. Mattress rests on pull-out part as well as on the kitchen module standing next to it. Sleeping surface: 210x137 cm. Scope of delivery: bed construction with slatted frame & comfort mattress as well as mounting adapters for original VW T7 floor rails.

11706

1269,-

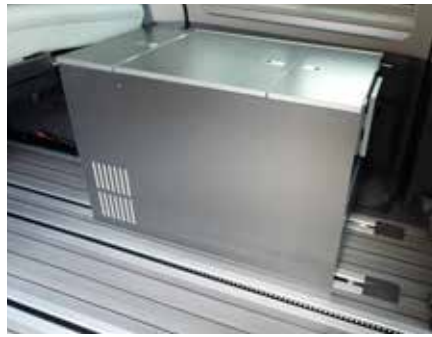

Kitchen module as a prefabricated part including mounted technology

The cooler module is mounted in the original Volkswagen T7 floor rails and can be removed again with a few simple steps. The kitchen module is equipped with Vitrifrigo top-loading compressor cooler TL 37L with a volume of 37 liters. The cooler can be conveniently operated from the top. The built-in water system consists of 1x 12 l fresh water and 1x 12 l waste water canister, a sink and a pull-out faucet with shower hose. Additional storage compartment offers space for a gas cartridge stove.

Height: 585 mm. Furniture decor: Pearl

11705

2490,-



Cartridge stove Camp Bistro DLX

With safety lock system and piezo ignition. Power: 2200 W, dims.: W37xD28xH12 cm, weight: app. 1.9 kg.

706474

64,99



Single-leg table system

The table stands on a single table column. The floor mount is fixed in the original vehicle rails. Outside the vehicle, the table can be used as a camping table with an optional tripod. Table top: 75x40 cm, decor: Pearl.

11707

199,-



Tripod for above table system

Tripod for the table top. Allows the table to be placed and used outside the vehicle.

57164

80,-



Curtain set, 8 pieces

8 curtains for complete blackout. Fastening in the living area by means of magnetic fastener, the cab curtain is attached with snaps.

372273

159,-



Multifunctional LithPowerUnit 48

32 Ah LiFePO4 battery. Rechargeable via 230 V, 12 V or solar. Wide range of connection options for drawing electricity for various end consumers. Integrated sine wave inverter, MPPT solar charge controller & battery management system. Dims.: LxWxH 325x198x185 mm, Weight: app. 8 kg.

814135

639,-



REIMO TRIOSTYLE - VOLKSWAGEN 6.1/6/5

Based on Volkswagen Transporter 6.1/6/5 station wagon SWB



5 stars on wheels.

- Exclusive fully equipped furniture unit with kitchen part, 39 l compressor refrigerator, closet and storage compartments
- Sliding and tool-free removable 3-person bench seat, equipped as standard with 3 three-point harnesses and 2 Isofix holders
- Top sleeping comfort due to flat lying surface of app. 205 x 131 cm
- Up to 7 luxurious seats with additional, retrofittable pilot seats
- Maximum flexibility due to variable living & storage space layout





Exclusive equipment.

The REIMO TrioStyle with exclusive camping full equipment embodies vacation travel & camping living comfort at highest level.

The noble furniture line w/ full equipment leaves nothing to be desired even on longer trips. Comfort-mobile TrioStyle in everyday life & work a large-capacity sedan w/ plenty of freedom of movement for 5-7 passengers (all seats w/ 3-point seat belts) & ample storage space in rear. Under the folded down rear cushion results in a storage height of a generous 46 cm.

In its free time, it transforms into an exclusive camping mobile with 2-4 full sleeping berths (sleeping roof optional).

For further equipment and options, please contact your specialist dealer. Find equipment for the long wheelbase Her at: www.reimo.com. Fig. partly show optional equipment that is not incl. in scope of delivery.

REIMO TRIOSTYLE - VOLKSWAGEN Transporter 6.1/6/5

Based on Volkswagen Transporter 6.1/6/5 station wagon SWB

Travel without compromise.

The exclusive kitchenette offers storage space for 39 liter compressor refrigerator (Dometic CRP40) and a storage compartment w/ elegant roll-up door for Porta Potti 335 camping toilet.

The installation of 2 sockets is provided on cabinet side wall (1x 12 V, 1x 230 V). The same position is also used for mounting the control panel of an optional Truma ECO gas heater. 2x 5 kg gas bottles find their safe place in the rear of the vehicle.



A clever expansion highlight is storage flap, which is integrated into underside of the bed.

It allows quick access to travel utensils and the luggage in the trunk from the vehicle interior, when bench seat is converted into sleeping bench.

This means you don't necessarily have to leave the vehicle, especially handy in bad weather.

Technical specifications

TrioStyle SWB:

Sleeps on sleeping/seating bench:	2
Sleeping berths w/ optional sleeping roof:	4
Light bed measure:	205 x131 cm dim. roof bed:
200 x 120 cm sleeping/sitting bench:	Variotech® 3000
Seats with three-point seat belts:	5
Stove:	2-burner gas stove*
Cooling unit:	Compressor refrigerator Dometic CRP 40 (app. 39 l)* Gas capacity: Space for 2x 5 kg gas bottle furniture construction: Poplar plywood with HPL laminate
Fresh water / waste water:	2x 12-liter or 49-liter fresh water tank / 27 l* Tall cabinet:117 x 126 x 33 cm
Overhead cabinet:	97 x 36 x 9 cm / app. 32 l
Rear storage space	
- with / without bench:	2600 l / 4300 l
- under bed extension:	WxHxD 112x40x63 cm
- under the bench:	75x28x43 cm / 90 l

*Included in the technology package

Total permissible mass:	3000 kg
payload without sleeping roof:	app. 640 kg
payload w/ sleeping roof:	app. 580 kg

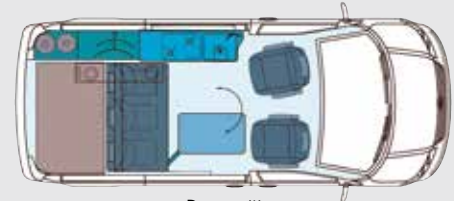

Day position

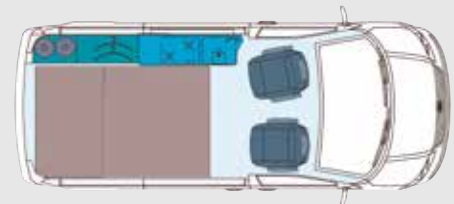

Night position



For further equipment and options, please contact your specialist dealer. Equipment for the long wheelbase can be found at: www.reimo.com. Fig. partly show optional equipment that is not incl. in scope of delivery.



Sleeping/seating bench Variotech® 3000

Three-seater, Gr. 10 Total width: 1205 mm, cushion width: 1150 mm, sleeping surface: 2050x1310 mm. 3 integrated, retractable headrests, 3 seat belts, Isofix attachment points for a maximum of 2 child seats (middle seat cannot be used when using a child seat), fold-up rear cushion (storage space height under rear cushion: 46 cm), 1 side panel. Ready upholstered incl. rear cushion. Bench sliding and removable. Rail spacing 651 mm. Fabric design: Classic gray, 2-tone.

5040000 4340,-

Grizzly glide bar set

For Variotech® 3000 SWB

58200 419,-

Fastening set

For slide rail set "Grizzly" for short wheelbase. For fastening the slide rails to the vehicle floor. Rail spacing 651 mm.

58204 219,-



Drawer optionally available

Provides additional storage space for e.g. shoes, cables or on-board tools. The drawer can be removed for loading long parts. Dims.: WxHxD: app. 49,5x17x69,5 cm. Décor: Basalt

5040090 679,-

Front panel optionally available

Mounting is made on the bench instead of a drawer. Front panel is removable and therefore offers a through-loading option for e.g. surfboard or skis up to a maximum length of 2.4 m. (Loading dimensions under the bench: WxH app. 60x31 cm. Décor: Basalt

5040080 249,-



Base plate 3-piece

made of waterproof chipboard w/ PVC covering. For original Volkswagen door sill. Rail spacing 651 mm Décor: ship's bottom

1053822 439,-

X-Trem insulator, 18 mm thickness

Extremely heat insulating & very light insulation. Needed under the base plate. Supplied as panels with 2 x 1 m. (2x for SWB)

50009 29,20



Furniture line as a finished part without tech. package

For Volkswagen T6.1/T6/T5 SWB. Generous Furniture part incl. tall cabinet w/ sliding door, linen comp., storage comp. for 2x 5 kg gas bottles. 2 drawers. A roller blind-cabinet offers plenty of space (e.g. forhem. Porta-Potti Qube 335 chem. toilet, 660102). Furniture line w/o. technology, appliances & inst. Dims. WxD app.. 236x35 cm. Décor: Apple laminate.

18050 3699,-



Technology package into above furniture line installed

Tech. package includes: Sink-cooker combination w/ glass cover, 2x 12-l fresh water canisters, 27-l waste water canisters, water tap, submersible pump 18 l & hoses, compressor refrigerator (Dometic CRP 40, app. 39 l), gas system prepared for 2x 5 kg gas bottle. 12 V/230 V system with Reimo fuse panel 714, Carbest switch-mode charger 15 A, circuit breaker 13 A with FI, CEE input socket and connection parts. 24 LED aluminum line light in kitchen part.

191005E 3999,-



Truma gas heater VarioHeat eco

Built in furniture unit, incl. fireplace. Opening for chimney as well as the chimney still have to be attached to the vehicle.

720304E 2529,-



Table decor mandarin

Table system with swivel table frame with bracket for mounting on the front panel of the bench. Table top in laminate, dimensions approx. 85 x 47 cm. Decor mandarin, table edge silver.

18052 339,-



Suspended roof cabinet for EasyFit sleeping roof w/ slatted bed As prefabricated part above rear bench seat for add. storage space. Cabinet pre-assembled. For short or long wheelbase with decor: apple laminate.

180541L 439,-



Portable camping toilet Porta Potti 335

Suitable for furniture line. High quality plastic for maximum hygiene.

660102 149,-

REIMO SPORTCAMPER - VOLKSWAGEN T6.1/T6/T5

Based on Volkswagen Transporter 6.1/6/5 station wagon SWB



Vehicle video
view

The sporty classic in a modern guise.

- The classic camping equipment in a shapely look w/ space for large 45-liter compressor refrigerator incl. ice compartment
- Fixed 3-person bench seat with 2 IsoFix holders and retractable headrests
- Double bed with level lying surface, sleeping width 190 x 131 cm
- Fully suitable as an everyday vehicle





The youthful leisure type.

REIMO SportCamper -
The classic camper with modern and functional interior.

Equipped with the Variotech® 3100 3-person comfort sleeper bench, large furniture unit w/ kitchen section, closet, storage compartments & swivel table, SportCamper already offers all requirements for perfect camping vacation in the basic version.

With its 5 seats it offers enough space even for the whole family
Space for travel and camping vacations.



For further equipment and options, please contact your specialist dealer. Find equipment for the long wheelbase
Her at: www.reimo.com. Fig. partly show optional equipment that is not incl. in scope of delivery.

REIMO SPORTCAMPER - VOLKSWAGEN T6.1/T6/T5

Based on Volkswagen Transporter 6.1/6/5 station wagon SWB



A lot of camper for little money.

The kitchen part with high-quality, resistant laminate surface offers particularly large work surface. The kitchen is prepared for sink and 2-burner stove.
The large closet can store plenty of vacation luggage.

The furniture line is completed by the included swivel table system and a gas bottle storage box in the rear, which is already prepared to hold 2x 5 kg gas bottles.



The storage space in the kitchen block is perfect for holding the optional portable toilet (Porta Potti 335).

The smart cutlery drawer with sliding shelf can be used as additional storage space.

In the large closet with retractable door, the table base is stored to save space.

With a few simple steps, the bench becomes a double bed. Flat sleeping surface without seams & straps ensures highest sleeping comfort on the road.



Technical specifications

SportCamper SWB:

Sleeps on sleeping/seating bench:	2
Sleeping berths w/ optional sleeping roof:	4
Light bed measure:	190 x 131 cm
Dimension roof bed:	200 x120cm sleeping/sitting bench:
	Variotech® 3100
Seats with three-point seat belts:	5
	Isobox bracket for 2 seats
Stove:	2-burner gas stove*
Refrigerator:	46-l compressor ref. * Gas capa.: space for 2x 5 kg gas bottle
Furniture constr.:	Poplar plywood with HPL laminate
Fresh water / waste water:	2x 12 l / 1 x 16 l
tall cabinet:	117 x 126 x 33 cm
Overhead cabinet:	97x36 x9 cm / app. 32 l
Storage space	
- in area of sliding door:	2000 l
- under bed extension:	WxHxD 67x40x73 cm
- under the bench:	67x30x50 cm / 100 l

*Included in the technology package

Total permissible mass:	3000 kg
payload without sleeping roof:	app. 640 kg
payload w/ sleeping roof:	app. 580 kg



Day position

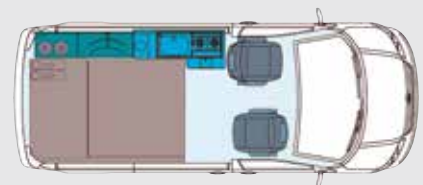

Night position

For further equipment and options, please contact your specialist dealer. Equipment for the long wheelbase can be found at: www.reimo.com. Fig. partly show optional equipment that is not incl. in scope of delivery.



Sleeping/seating bench Variotech® 3100 rigid

Three-seater, total width: 1205 mm, cushion width: 1150 mm, sleeping surface: 1900x1310 mm. 3 integrated retractable headrests, 3 seat belts (size 10). For maximum 2 child seats (middle seat not usable when using a child seat). Fold-up Rear cushion (storage height under rear cushion: 46 cm), side panel. Ready upholstered incl. rear cushion sleeping/seating bench not removable.

Table system incl. in scope of delivery of furniture line. Fabric design: Classic gray, 2-color.

5040600 3890,-

Mounting material bench:

Beam 1	582081	32,95
Beam 2	582082	44,95
Beam 4	582084	289,-
Mounting kit	58208	89,90



Drawer, mounted

Provides additional storage space for e.g. shoes, cables or on-board tools. The drawer can be removed for loading long parts. Dims. WxHxT: 49.5x17x69.5 cm.

Décor: Basalt

5040690 549,-



Front panel, mounted

Mounting is made on the bench instead of a drawer. Front panel is removable & therefore offers a through-loading option for e.g. surfboard or skis up to a length of max. 2.4 m. Loading dims. in middle under the bench: WxH app. 60x31 cm. Décor: Basalt

5040680 259,-

Base plate 1-piece .

made of waterproof chipboard w/ PVC covering. For original Volkswagen door sill. Décor: ship's bottom.

1053812 379,-



Fig. shows decor granitto

Furniture line as finished part without tech. package incl. swivel table system

Besting of: Clothes/linen closet w/ retractable door, additional linen & storage compartments in rear area. In the gas box is space for 2x 5 kg gas bottles. Kitchen part w/ space for 2-burner stove & Stainless steel sink. Plenty of space in storage comp. & drawer, space for refrigerator. Swivel table system w/ attachment to bench, compartment for Porta Potti Qube 335 (660102). Cutouts for laying gas, water and electric. Robust worktop in HPL laminate. Furniture line available in decor apple laminate with edges in silver or decor granitto. Swivel table system with bracket for mounting on the front panel of the bench included. Table top (approx. 80x 47 cm) decor Pearl.

104900 as finished part, decor apple 2290,-

104904 as finished part, decor granitto 1999,-



Technology package, kit

(not in above furniture line inst.)

SportCamper technical package for self-installation incl.:

Water system w/ 2x 12 l fresh water canister & 1x 16 l waste water canister. Faucet, submersible pump 16 l and stainless steel sink. Gas system with 2-burner hob, gas regulator, hose, gas pipe and small parts.

10496T as kit 619,-



We recommend the following heating system:

Carbest VanHeat 2.0-DH

Diesel parking heater for mounting under passenger seat, power 2 kW, incl. height kit up to 5.000 m and contr. panel. With extensive mounting material. Approval according to UN ECE R122, approval by Federal Motor Transport Auth. acc. to UN ECE R10.

48182 649,-



Compressor refrigerator CV50L High quality

Compressor refrigerator w/ 46 l volume incl. freezer comp. Door hinge on right, w/ LED operating display.

713572 679,-



Suspended roof cabinet for EasyFit sleeping

roof w/ slatted bed As prefabricated laminate part above rear bench seat for add. storage space. Cabinet pre-assembled. For short or long wheelbase.

104941 as finished part, decor apple 399,-

104941GR as finished part, decor granitto 399,-



Portable camping toilet Porta Potti 335

Suitable for SportCamper furniture line. High-quality plastic for maximum hygiene.

660102 149,-

REIMO TRAVELSTYLE - VOLKSWAGEN T6.1/T6/T5

Based on Volkswagen Transporter 6.1/6/5 station wagon SWB



Motorhome in van format.

- Spacious furniture unit w/ large kitchen block, 45-l compressor refrigerator, closet and toilet compartment
- 3-person bench seat, rigid, standard w/ 3 three-point seat belts and 2 Isofix holders
- Double bed with flat lying surface, ca. 190x131 cm
- Integrated closet with ample storage volume
- Thanks to the removable seat cover, even bulky vacation luggage can be like snowboard, ski or surfboard can be transported comfortably





Comfort camping equipment.

The REIMO TravelStyle is the ideal family camper for 3 people. The sleeping/seating bench Variotech 3100 with 3 seats offers enough space for the whole family for a pleasant travel comfort and relaxed camping vacation.

The TravelStyle is equipped with a comfortable L-shaped kitchenette, a large cooker-sink combination with glass cover as well as several drawers, a closet and storage compartments. An integrated, swiveling shelf provides additional work surface. Compressor refrigerator with freezer compartment offers enough space for your food.

For further equipment and options, please contact your specialist dealer. Find equipment for the long wheelbase. Her at: www.reimo.com. Fig. partly show optional equipment that is not incl. in scope of delivery.

REIMO TRAVELSTYLE - VOLKSWAGEN T6.1/T6/T5

Based on Volkswagen Transporter 6.1/6/5 station wagon SWB



Travel in style.

The 3-person bench seat with retractable headrests and 2 Isofix mounts for 2 child seats folds down into a comfortable double bed. Thanks to the removable front panel, long parts such as surfboards and skis can be easily loaded under the seat. Size of through-loading fac.: WxHxD app. 60x28x240 cm.

Integrated 46 liter compressor refrigerator, the generous storage compartments & prepared storage compartment for mobile camping toilet (Porta Potti 335) leave nothing to be desired on family camping vacation.



A clever detail of the equipment is the retractable shelf, which can be easily swung out of the kitchen unit when needed and provides additional work space.

The integrated water system with 2x 12 Liter canisters provides you with fresh drinking water during the vacation.

For further equipment and options, please contact your specialist dealer.
Equipment for the long wheelbase can be found at: www.reimo.com.
Fig. partly show optional equipment that is not incl. in scope of delivery.

Tech. specifications

TravelStyle SWB.

Sleeps on sleeping/seating bench:	2
Light bed size sleeping bench:	190 x 131 cm
Sleeping berths w/ optional sleeping roof:	4
Dimension roof bed:	200 x 120 cm sleeping/ sitting bench:
	Variotech® 3000
Seats with three-point seat belts:	5
Stove:	2-burner gas stove*
Cooling unit:	Compressor refrigerator,
46 l* gas capacity:	Space for 2x 5 kg gas
bottle Furn. constr.:	Poplar plywood with HPL laminate
Fresh water / waste water:	2x 12 l / 16 l*
tall cabinet:	117 x 126 x 33 cm
Overhead cabinet:	97 x 36 x 9 cm / approx. 32 l

Storage space

- in area of sliding door:	2000 l
- under bed extension:	WxHxD 67x40x73 cm
- under the bench:	50x67x30 cm / 100 l

*Included in the technology package

Total permissible mass:

	3000 kg
payload without sleeping roof:	app. 640 kg
payload w/ sleeping roof:	app. 580 kg



Day position

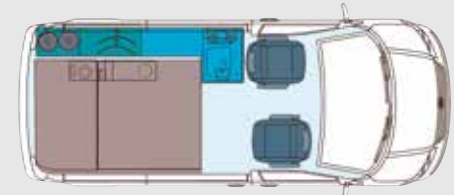

Night position



Fig. 1 shows furniture line with additional cabinet for long wheelbase.



Sleeping/seating bench Variotech® 3100 rigid

3-seater, total width: 1205 mm, cushion width: 1150 mm, sleeping surf.: 1900x1310 mm. 3 integrated retractable headrests, 3 seat belts (size 10). For maximum 2 child seats (middle seat not usable when using a child seat). Fold-up Rear cushion (storage height under rear cushion: 46 cm), side panel. Ready upholstered incl. rear cushion sleeping/seating bench not removable. Table system incl. in scope of delivery of furniture line. Fabric design: Classic gray, 2-color.

5040600 3890,-

Mounting material bench:

Beam 1	582081	32,95
Beam 2	582082	44,95
Beam 4	582084	289,-
Mounting kit	58208	89,90



Drawer

Provides additional storage space for e.g. shoes, cables or on-board tools. The drawer can be removed for loading long parts. Dims. WxHxD: 49,5x17x69,5 cm. Décor: Basalt

5040690 549,-

Front panel

Mounting is made on the bench instead of a drawer. Front panel is removable & therefore offers a through-loading possibility for e.g. surfboard or skis up to a max. length of 2.4m (through-loading dims. under bench: WxH app. 60x31 cm). Décor: Basalt

5040680 259,-



Base plate 1-piece

made of waterproof chipboard w/ PVC covering. For original Volkswagen door sill. Décor: ship's bottom.

1053812 379,-

X-Trem insulator, 15 mm thickness

Extremely heat insulating & very light insulation. Needed under the base plate. Supplied as panels with 2 x 1 m.

50009 29,20



Furniture line as finished part without tech. package incl. swivel table system

(Fig. shows furniture line incl. tech. package) with space for stove & sink 600 x 455 mm, compr. refrigerator CV50L 46 l (713572), Porta Potti 335 (660102).

Equipment: furniture line with swiveling table, 2 kl. Drawers & 2 larger storage compartments. Cover/work top in laminate with real wood edges. Décor: walnut. High & linen cupboard w/ large cupboard comp., sliding door, linen compartment & gas box for app. 2x 5 kg gas bottle. Swivel table system with bracket for mounting on the front panel of the bench included. Table top in laminate. Decor high gloss white, dims. app. 85 x 47 cm. Table edge silver.

Kitchen part as finished pt.

190921 1299,-

Tall and linen closet

190911 1199,-



Technology package, kit

Consisting of: Sink/stove combination with glass cover, 2x 12 l fresh water canister, 1x 16 l waste water canister, water tap, 18 l submersible pump, gas system prepared for 2x 5 kg gas cylinder and distribution block with 3 outlets, 12 V system with 1x 12 V built-in socket and 714 fuse panel.

19100T as kit 939,-



Heating systems

We recommend the following heating systems:

Diesel parking heater Carbest VanHeat

2.0-DH 2 kW power, integr. alt. adjustment up to 5,000 m, type app. acc. to UN ECE R122, app. by German Federal Motor Transport Authority according to UN ECE R10, incl. LCD control panel, tank extraction set & extensive inst. material.

48182 649,-

Truma VarioHeat eco gas heater for inst. in furniture line, power 2.8 kW, incl. control panel & installation material.

720305 1589,-



Compressor refrigerator CV50L High quality

Compressor refrigerator w/ 46 l volume incl. freezer comp. Door hinge on right, w/ LED operating display.

713572 679,-



Suspended roof cabinet for EasyFit sleeping roof w/ slatted bed

As prefabricated part above rear bench seat for add. storage space. Cabinet pre-assembled. For short or long wheelbase with decor: walnut laminate.

190932 419,-



Portable camp. toilet Porta Potti 335

Suitable for TravelStyle furniture line. High quality plastic for maximum hygiene.

660102 149,-

REIMO CITYVAN - VOLKSWAGEN Transporter 6.1/6/5

Based on Volkswagen Transporter 6.1/6/5 station wagon SWB



The true multifunctional mobile.

- Generous space concept with huge luggage volume and through-loading poss. up to 3.5 meters
- Super slim functional furniture line with integrated compressor cooler, Stainless steel sink w/ water system & prepared stove storage compartment
- Sliding and tool-free removable 3-person bench seat, equipped as standard with 3 three-point harnesses and 2 Isofix holders
- Large double bed (205x136 cm) with level lying surface
- Up to 7 luxurious seats with additional, retrofittable pilot seats
- Maximum flexibility due to variable living and storage space layout





All-rounder with cargo volume.

The CityVan unites through its multifunctionality. Everyday practicality and camping vacation in one vehicle.

Its spacious room concept and its transformability offer you almost limitless possibilities for any situation.

The large free space in vehicle offers plenty of room, even for pets and sports equipment.

With 5 to 7 comfortable seats, a slim functional furniture line, up to 4 sleeping berths (sleeping roof optional) and ample storage space, the CityVan is a leisure and everyday vehicle in one.

46 cm of storage space with the rear shelf folded down also allow large luggage to be stowed while the bench is converted into a bed.

The bench seat can be moved to just behind the cab seats, creating a mega trunk volume of about 4800 liters.

Ideal, for example, to transport bicycles for active vacations.



For further equipment and options, please contact your specialist dealer. Find equipment for the long wheelbase
 Here at: www.reimo.com. Fig. partly show optional equipment that is not incl. in scope of delivery.

REIMO CITYVAN - VOLKSWAGEN Transporter 6.1/6/5

Based on Volkswagen Transporter 6.1/6/5 station wagon SWB

Trip. Free time. Everyday life.

REIMO CityVan embodies multifunctional driving fun and at the same time offers extensive, standard camping equipment for the most beautiful camping vacations and leisure trips.

Stainless steel sink (325x176 mm), a 13 liter fresh water canister & a 13 liter waste water canister are compactly integrated in slim furniture unit.

Several storage compts. offer storage space for additional vacation utensils.



Even 1.5 liter bottles can be stored upright in the standard 26 liter compressor cooler.

The top-loader design makes filling and removing the contents a breeze.

Since the cooler is integrated at handle height directly in the furniture line, cool drinks are always at hand, even when the bench is converted into a bed.

The CityVan offers a through-loading option up to 2.4 m in length with seat bench panel removed or seat bench drawer removed.

Size of the hatch: WxH approx. 76x28 cm. Perfect for transporting e.g. surfboard, ski or snowboard.



For further equipment and options, please contact your specialist dealer. Find equipment for the long wheelbase
Her at: www.reimo.com. Fig. partly show optional equipment that is not incl. in scope of delivery.



Technical specs.

REIMO CityVan short wheelbase:

Sleeps on sleeping/seating bench:	2
Sleeping berths w/ optional sleeping roof:	4
Light bed measure:	205 x 136 cm dim. roof bed:
200 x 120 cm sleeping/sitting bench:	Variotech® 3000
Seats with three-point seat belts:	5
Cooling unit: Compressor cooler (26 l)* Furniture constr.:	Poplar plywood with HPL laminate
Fresh water / waste water:	13 l / 13 l*
Overhead cabinet:	123 x 27 x 11 cm / app.
36 l rear storage space	
- with / without bench:	2700 l / 4500 l
- under bed extension:	WxHxD 120x40x63 cm
- under the bench:	63x31x90 cm / 175 l
	*Optional

Total permissible mass:	3000 kg
payload without sleeping roof:	720 kg payload
with sleeping roof:	660 kg

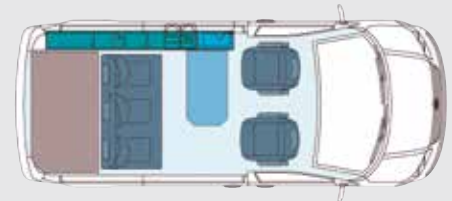

Day position

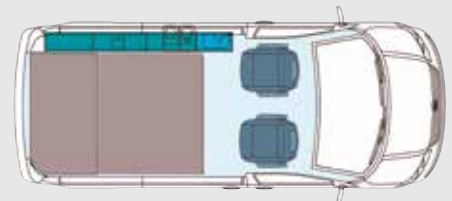

Night position

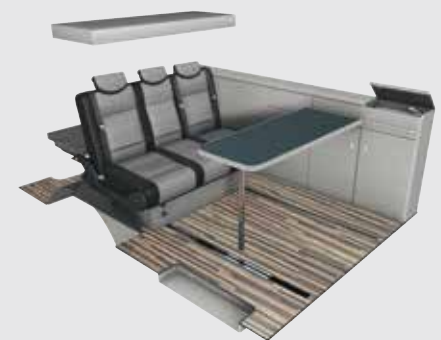



Sleeping/seating bench Variotech® 3000

Bench sliding and removable. Three-seater, Gr. 14, total width: 1305 mm. Upholstery width: 1250 mm, sleeping surface: 2050x1360 mm. 3 integrated retractable headrests, 3 seat belts, Isofix attachment points for a maximum of 2 child seats (middle seat cannot be used when a child seat is used), fold-up rear upholstery (storage height under rear upholstery: 46 cm), side panel. Ready upholstered incl. rear cushion. Rail spacing 826 mm. Fabric design: Classic gray, 2-tone.

5040100 4890,-

Slide rail set "Grizzly" short wheelbase

For Variotech® 3000

58200 419,-

Fastening set

For slide rail set "Grizzly" for short wheelbase. For fastening the slide rails to the vehicle floor. Rail spacing 826 mm.

58203 239,-



Drawer

Provides additional storage space for e.g. shoes, cables or on-board tools. The drawer can be removed for loading long parts. Dims. WxHxD: app. 66,5x17x69,5 cm. Décor: Basalt

5040190 679,-

Front panel

Mounting is made on the bench instead of a drawer. The front panel is removable and therefore offers a through-loading possibility for e.g. surfboard or skis up to a max. length of 2.4m (through-loading dimensions under the bench:

WxH app. 75x31 cm). Décor: Basalt

5040180 249,-



Base plate 3-piece, rail spacing 826 mm.

made of waterproof chipboard w/ PVC covering. For original VW door sill. Décor: ship's bottom

1053832 439,-

X-Trem insulator, 18 mm thickness.

Extremely heat insulating & very light insulation. Is needed 2x under the base plate for SWB. Supplied as panels with a 2 x 1 m.

50009 29,20



Furniture line as a finished part without technical pack.

Elegant furn. part w/ cover flaps. Prepared for installation of water system, compact sink and cooler box. Series decor: anthracite metallic.

10794 2789,-



Tech. package - built in above furniture line

Water system: with sink, water tap, 2x 13 l fresh & waste water canisters, submersible pump.

12 V: With additional fuse panel 714.

60004E Water system 399,-

60004EE Water system + 12 V 699,-

Slim 26 liter Reimo compressor cooler with plenty of space and only 200 mm deep. Temperature range from +1° C to 10° C. External cooling unit, Danfoss BD 2.5 compressor. Dims.: app. W 570 x D 200 x H 360 mm. Weight app. 18.9 kg. Compressor cooler 26 l, built in furniture line

71177E 1319,-



Cartridge stove Camp Bistro DLX

With safety lock system and piezo ignition.

Power: 2200 W, Dims.: WxHxD 37x12x28 cm, Weight: app. 1.9 kg

706474 64,99



Diesel parking heater Carbest VanHeat 2.0-DH

For mounting under passenger seat, power 2 kW, incl. altitude kit up to 5,000 m and digital control panel. Incl. Tank removal set and extensive mounting material.

48182 649,-

Mounting bracket under front passenger seat
481821 49,95



Pearl table decor

Table system with wall bracket

with folding table base & table slide rail.

Table top in laminate decor, Pearl, dims. app. 85 x 47 cm.

Table edge: high gloss anthracite silver.

50158 255,-



Suspended roof cabinet for EasyFit sleeping

roof w/ slatted bed As prefabricated part above rear bench seat for add. storage space. Cabinet pre-assembled. For short or long wheelbase with decor: high-gloss anthracite-silver.

10820L 599,-



PortaPotti Box

made of HPL laminate with upholstered pad. Décor: Anthracite Silver (Without Porta Potti Toilet)

10696 839,-

Portable camping toilet Porta Potti 335

Suitable for Porta Potti kit. High quality plastic for maximum hygiene.

660102 149,-

REIMO WEEKENDER PLUS - VOLKSWAGEN T6.1/T6/T5

Based on Volkswagen Transporter 6.1/6/5 station wagon SWB



Family van with XXL double bed

- Large bed with flat sleeping surface over entire interior width of vehicle (app. 200x155 cm), without disturbing seams or belts
- Sliding 3-person bench seat, equipped as standard with 3 three-point seat belts and 2 Isofix holders
- Compact kitchen unit with sink and water system, prepared for optional gas cartridge stove
- Includes storage box with 12 V socket for optional cool box
- Up to 7 luxurious seats due to additional, retrofittable pilot seats with bonded floor rails





XXL sleeping pleasure on the road.

REIMO Weekender Plus is the all-rounder for everyday life, work and leisure. The heart of this camper is the XXL bed with a generous lying surface of approx 200x155 cm. The flat sleeping surface extends across the entire interior width of the vehicle.

Next to the huge bed is a slim kitchen module with sink and water system. Perfect for weekend trips and short vacations. Side storage boxes provide enough space for small travel accessories and an optional cooler.

The Variotech® 3000 comfort bench can be easily moved, allowing flexible living and storage layout. Only one travel position possible with bolted floor rails.



For further equipment and options, please contact your specialist dealer. Find equipment for the long wheelbase. Her at: www.reimo.com. Fig. partly show optional equipment that is not incl. in scope of delivery.

REIMO WEEKENDER PLUS - VOLKSWAGEN T6.1/T6/T5

Based on Volkswagen Transporter 6.1/6/5 station wagon SWB

Family van for leisure & everyday life.

In the REIMO Weekender Plus there is a compact kitchen unit with integrated sink and water system. Swiveling kitchen block cover becomes an additional storage surface with a flick of the wrist. A large side storage box offers enough space for everything that needs to be there. The upholstered surface of the stowage box not only creates a homely ambience in the vehicle, but at the same time widens the sleeping area to the entire width of the vehicle.



Sink & water system are compactly located in the kitchen block. A fresh water canister and a waste water canister, each with a capacity of 13 l, are integrated in the base cabinet for easy access.



As optional equipment you can get a bench drawer. Offers storage space for e.g. shoes, cables or sleeping bags as well as other vacation luggage. The drawer can be removed for loading long parts. This creates a loading hatch in the Size WxHxD: 66,5x17x69,5 cm.

For further equipment and options, please contact your specialist dealer. Equipment for the long wheelbase can be found at: www.reimo.com. Fig. partly show optional equipment that is not incl. in scope of delivery.

Technical specifications REIMO Weekender Plus short wheelbase:

Sleeps on sleeping/seating bench:	2
Sleeping berths w/ optional sleeping roof:	4
Light bed size without storage box:	205 x130 cm
Light bed size with storage box:	app. 205 x160 cm
sleeping/seating bench:	Variotech® 3000
Seats with three-point seat belts:	5
Furniture constr.:	Poplar plywood with HPL laminate
Overhead cabinet:	97 x 36 x9 cm / app. 32 l
Rear storage space	
- with / without bench:	2800 l / 4700 l
- under bed extension:	WxHxD 120x40x63 cm
- under the bench:	75 x 28 x43 cm / 90 l

Total permissible mass:	3000 kg
Payload w/o. sleeping roof:	app. 640 kg
payload w/ sleeping roof:	app. 580 kg



Day position

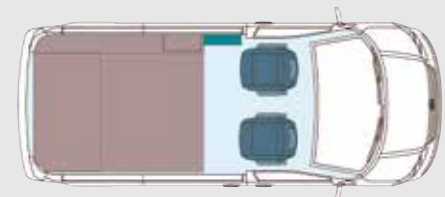

Night position





Sleeping/seating bench Variotech® 3000

3-seater, Gr. 14, total width: 1305 mm. Upholstery width: 1250 mm, sleeping surf.: 2050x1300 mm. 3 integrated, retractable headrests, 3 seat belts, Isofix attachment points for a maximum of 2 child seats (middle seat cannot be used when a child seat is used), fold-up rear upholstery (storage space height under rear upholstery: 46 cm), side panel. Ready upholstered incl. rear cushion. Bench sliding and removable. Rail spacing 826 mm. Fabric design: Classic gray, 2-tone.

5040200 4890,-

Slide rail set "Grizzly" SWB

For Variotech® 3000

58200 419,-

Including fastening set

For slide rail set "Grizzly" for short wheelbase. For fastening the slide rails to the vehicle floor. Rail spacing 826 mm.

58203 239,-



Drawer

Provides additional storage space for e.g. shoes, cables or on-board tools. The drawer can be removed for loading long parts. Dims. WxHxD: app. 66,5x17x69,5 cm. Décor: Basalt

5040190 679,-

Front panel

Mounting is made on the bench instead of a drawer. Front panel is removable & therefore offers through-loading possibility for e.g. surfboard or skis up to a max. length of 2.4 m (through-loading dimensions under bench: WxH app. 75x31 cm). Décor: Basalt

5040180 249,-



Base plate 3-piece, rail spacing 826 mm. made of waterproof chipboard w/ PVC covering. For original VW door sill. Décor: ship's bottom

1053832 439,-

X-Trem insulator, 18 mm thickness

Extremely heat insulating & very light isolation. Is needed under the base plate 2x for SWB. Supplied as panels with a 2 x 1 m.

50009 29,20



Kitchen module included Features

Compact kitchen block and side storage box made of HPL laminate anthracite silver. Storage box is accessible from interior & from rear. The padded surface enlarges the bed in the sleeping position to full vehicle width. Mini sink, pull-out, 1x 13 l Fresh water canister, 1 x 13 l waste water canister.

① **Kitchen module 10689 1499,-**

② **Storage box SWB 10696 839,-**



Cartridge stove Camp Bistro DLX

With safety lock system and piezo ignition. Power: 2200 W, Dims.: WxHxD 37x12x28 cm, Weight: app. 1.9 kg

706474 64,99



Diesel parking heater Carbest VanHeat 2.0-DH

For mounting under passenger seat, power 2 kW, incl. altitude kit up to 5,000 m and digital control panel. Incl. Tank removal set and extensive mounting material.

48182 649,-

Mounting bracket under passenger seat

481821 49,95



Pearl table decor

Table system with swivel table frame with bracket for attachment to the front panel of the bench. Tabletop in laminate, Pearl decor, dimensions approx. 85 x 47 cm. Table edge silver.

18052 339,-



Suspended roof cabinet for EasyFit sleeping roof w/ slatted bed As prefabricated part above rear bench seat for add. storage space. Cabinet pre-assembled. For short or long wheelbase with Décor: Anthracite silver.

10820L 599,-



Porta-Potti Box

made of HPL laminate with upholstered pad. (Without Porta Potti toilet) Décor: Anthracite silver

10696 839,-



Portable camping toilet Porta Potti 335

Suitable for Porta Potti kit. High quality plastic for maximum hygiene.

660102 149,-

REIMO WEEKENDER - VOLKSWAGEN Transporter 6.1/6/5

Based on Volkswagen Transporter 6.1/6/5 station wagon SWB

Large capacity van for up to 7 people.

- Sliding and tool-free removable 3-person bench seat, equipped as standard with 3 three-point harnesses and 2 Isofix holders
- Large, flat lying surface of app. 205 x 150 cm over entire width of vehicle
- As supplement there are different kitchen modules & CampingBoxes to choose from



Whether for business, everyday life or leisure - the REIMO Weekender is the perfect first vehicle for any occasion.

All-rounder Weekender is large-capacity sedan for everyday & professional use w/ plenty of room to move for 5-7 passengers (all seats w/ 3-point seat belts) and ample storage space in rear.

In the free time it becomes with the optional kitchen block the perfect travel companion with 2 - 4 full sleeping places. (sleeping roof opt.)

Whether with 1 or 2 sliding doors, with or without a kitchen block, elegantly equipped on a Caravelle Comfortline basis or purely functional & robust on a Transporter Kombi basis - choice is yours.

Weekender with Easy swivel kitchen

- Easy kitchen swivels outwards for installation behind the cab seats on the driver's or passenger's side (swivel bracket available as an option)
- The Easy kitchen can alternatively be mounted in the floor rails (without swivel function)
- The kitchen module can also be completely removed from the vehicle, ideal for convenient cooking outside the vehicle
- Stainless steel sink & water system w/ 12-liter fresh water & 12-liter waste water canisters
- Plenty of storage space, large drawer
- 2 handles for easier lifting
- The kitchen block can remain at home in everyday use (with car registration)



You can find the matching Easy kitchen on page 69

For further equipment and options, please contact your specialist dealer. Find equipment for the long wheelbase. Her at: www.reimo.com. Fig. partly show optional equipment that is not incl. in scope of delivery.

Technical specs.:

REIMO Weekender short wheelbase:

- Sleeps on sleeping/seating bench: 2
- Sleeping berths w/ optional sleeping roof: 4
- Light bed measure: app. 205 x160 cm
- sleeping/seating bench: Variotech® 3000
- Seats with three-point seat belts: 5
- Rear storage space
- with / without bench: 3100 l / 5100 l
- under bed extension: WxHxD 122x40x63 cm
- under the bench: 75 x 28x43 cm / 90 l

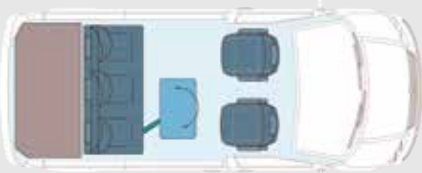

Day position

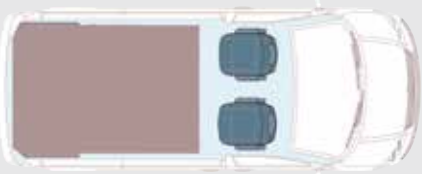

Night position



Vehicle video view



Sleeping/seating bench Variotech® 3000

Bench sliding and removable. For vehicles w/o. lateral . Plastic cladding. Three-seater, Gr. 17, total width bench: 1380 mm. Upholstery width: 1330 mm, sleeping surface: app. 2050x1600 mm. 3 integrated retractable headrests, seat belts. Isofix attachm. points for max. 2 child seats (middle seat not usable when using a child seat), fold-up rear upholstery (storage space height under rear upholstery: 2 cm) Rear cushion (storage space height under rear cushion: 46 cm), front panel & side panel. Ready upholstered incl. rear cushion. Rail spacing 997 mm.

Fabric design: Classic gray, 2-tone.

5040300 4990,-

"Grizzly" glide bar set

For Variotech® 3000 SWB

58200 419,-

Fastening set

For slide rail set "Grizzly" for short wheelbase. For fastening the slide rails to the vehicle floor. Rail spacing 997 mm.

58202 219,-

Alternatively, the sleeping/seating bench Variotech® 3100 rigid (Gr. 17) can be installed. For all details, see page 151.



1 Drawer

Provides additional storage space for e.g. shoes, cables or on-board tools. The drawer can be removed for loading long parts. Dims. WxHxD: app. 83,5x17x69,5 cm. Décor: Basalt

5040390 679,-

2 Front panel

Mounting is made on the bench instead of a drawer. Front panel is removable & therefore offers through-loading possibility for e.g. surfboard or skis up to a max. length of 2.4 m (through-loading dimensions under bench: WxH app. 80x31 cm). Décor: Basalt

5040380 249,-



Base plate 3-piece .

made of waterproof chipboard w/ PVC covering. For original VW door sill. Rail spacing 997 mm. Décor: ship's bottom

1053842 439,-

X-Trem insulator, 18 mm thickness

Extremely heat insulating & very light insulation. Is needed under the base plate 2x for SWB. Supplied as panels of 2 x 1 m.

50009 29,20



Pearl table decor

Table system with swivel table frame

With bracket for attachment to the front panel of the bench. Tabletop in laminate, Pearl decor, dims. app. 85 x 47 cm. Table edge silver.

18052 339,-



Suspended roof cabinet for EasyFit sleeping roof w/ slatted bed As prefabricated part above rear bench seat for add. storage space. Cabinet pre-assembled. For short or long wheelbase with decor: Anthracite Metallic.

10820L 599,-



For further equipment and options, please contact your dealer

MULTIFUNCTIONAL KITCHEN PARTS PANTRY

For REIMO Weekender and Volkswagen Multivan

With the functional pantry kitchen parts, you can quickly and easily transform your REIMO Weekender or Volkswagen Multivan into a practical and comfortable camper.



With complete camping basic equipment. 2x 12 liter canisters for fresh water and waste water are located in the rear part of the kitchen section and are concealed by the backrest of the cab seat. Each part of the kitchen is equipped with a drawer and a spacious storage compartment.

Intended for a built-in sink with integrated glass cover (70135). A folding table can be mounted either on the right or left, so the kitchen parts can be used on the driver's or passenger's side. Noble furniture constr. w/ distinctive rounded aluminum edges in front.

Fastening in the seat mounting rails. The kitchen part fits exactly between the front edge of the bench (converted into a bed) and the front seats. Dims.: WxHxD 65x73x48.5 cm.

With sink, glass cover and technology. Installed ready for connection with 12 V plug. (weight approx. 35kg).

Furniture decor:

Anthracite metallic	11100T	1499,-
High gloss silver	11100TS	1499,-
High gloss white	11100TW	1499,-
High Gloss Black	11100TB	1499,-

Optional accessories: 1-burner gas cartridge stove Camp Bistro DLX w/ safety lock system & piezo ignition. Power: 2200 W, dimensions: WxHxD 37x12x28cm. Weight app. 1.9 kg. **706474 64,99**



Plenty of storage space. Large drawer. (Pot and stove not included) (Stove not included)



PANTRY - THE MULTIFUNCTIONAL KITCHEN PARTS

MULTIFUNCTIONAL EASY KITCHEN

For Volkswagen Transporter 6.1/6/5 Kombi, SWB or LWB and Mercedes-Benz Vito long

- **Removable Easy kitchen section for installation behind the driver or front passenger seat**
- **Can be swung out with optional swivel fitting**
- **w/ stainless steel sink & water system**
- **Convenient cooking outside the vehicle**
- **No odor nuisance in the interior**
- **Plenty of storage space, large drawer**
- **The kitchen block can stay at home in everyday use**



Equipment:

- ① Stainless steel sink
- ② Pull out faucet with shower hose
- ③ Water system with submersible pump (connection to 12 V socket) and one 10 liter fresh and one 10 liter waste water canister each
- ④ 1 drawer for cutlery and dishes
- ⑤ 1 storage comp. for pots & dishes
- ⑥ Storage comp. for gas cartridge stove
- ⑦ 2 side folding tables 388 x 295 mm
- ⑧ 2 handles for easier lifting

Kitchen part pre-assembled with built-in technology, including fastening material for Reimo floor rails.

Kitchen part for installation right/left behind driver's cab seats in VW T6.1/T6/T5 Kombi/Caravelle in connection w/ a Reimo sleeping bench V3000 (not suitable for Multivan & California Beach).

For installation behind passenger seat in Mercedes-Benz Vito. In combination with a REIMO sleeping bench V3000 the full bed length can be used.

Overall dims.: W 595 mm (tables folded down), H 730 mm x D 450 mm (pl. canister 76 mm)

Furniture decor: High gloss white

for mounting right **11112 1929,-**
for mounting left **11113 1999,-**

High gloss silver
for mounting right **11112S 1929,-**
for mounting left **11113S 1999,-**

Matte black

for mounting right **11112B 1999,-**
for mounting left **11113B 2099,-**

Optional accessories:

⑨ Matching swivel unit

(for inst. on B-pillar w/ suitable tool)

for VW right-hand installation **11114 499,-**

for VW mounting left **11115 499,-**

for Mercedes-Benz Vito long (only possible with Easy kitchen) **57112 499,-**

⑩ Cartridge stove Camp Bistro DLX

With safety lock system and piezo ignition.

Power: 2200 W, dimensions: WxHxD

37x12x28cm.

Weight: app. 1.9 kg

706474

64,99

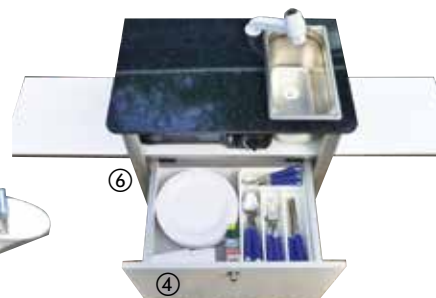

Mercedes-Benz Vito long wheelbase can be found on page 84/85

Shown kitchen accessories and stove of this page are not included.

REIMO BIKE'N'SURF - VOLKSWAGEN Transporter 6.1/6/5

Based on Volkswagen Transporter 6.1/6/5 station wagon SWB

Comfort bed at the top price.

- Camper van equipment with huge storage space
- Easy installation in the vehicle by bolting to existing points
- Comfortable maxi bed with a lying surface of 198 x 130 cm
- Comfort upholstery w/ slatted frame & 11 cm thick mattress
- Huge storage space due to adjustable bed height



Sleep, stow, live:

Comfortable bed w/ lush cold foam mattress and a lying surface of 198 x 130 cm is adjustable in height, providing a huge storage space underneath from 55 to 80 cm in height in full interior width. Good for the luggage! The original bench in the 2. Row of seats can remain installed and is simply folded down to make the bed. This gives you 4 seats for driving and a comfortable bench seat for living.



High quality
Cover fabric



Sport load:

If you like to stow your bike or other bulky sports equipment inside the vehicle, use the space next to the bed for this purpose.

Cook and enjoy fresh:

In addition to a cabinet element, an optional Cooky kitchen module with 4 practical functions is available:

Removable compressor cooler with 18 liters capacity, pull-out for gas cartridge stove, drawer for dishes, cutlery and utensils and a table (usable in 2 heights) perfect for outdoor breakfast or washing dishes. Another sliding table is located in the living area inside.

All expansion modules are inserted and removed just as quickly in a few simple steps without tools or modifications to the vehicle.

For further equipment and options, please contact your specialist dealer. Equipment for the long wheelbase can be found at: www.reimo.com. Fig. partly show optional equipment that is not incl. in scope of delivery.

Technical specifications

Bike'n'Surf SWB:

Sleeping places on bed construction: 2
 Sleeping berths w/ optional sleeping roof: 4
 bed size sleeping roof: 200x120cm
 Light bed measure: 198x130 cm
 Seats with three-point seat belts: 2
 Stove: 1-burner gas stove*
 Cooling unit: Compressor cooler Coolfreeze CDF 18*
 Gas capacity: Space for 2x 5 kg gas bottle
 furniture construction: Poplar plywood with HPL laminate
 Fresh water / waste water: 1x 12 l / 12 l*
 tall cabinet: WxHxD app. 100x131x39 cm

Storage space under bed:

Bed height 1: 510 mm load. height
 Bed height 2: 570 mm load. height
 Bed height 3: 670 mm load. height

*Incl. in optional technology package

Total permissible mass: 3000 kg
 payload without sleeping roof: app. 640 kg
 payload w/ sleeping roof: app. 580 kg

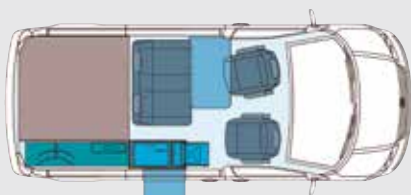

Day position

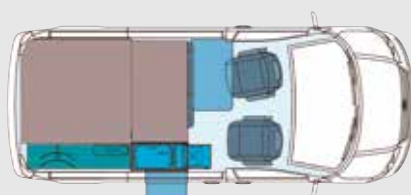

Night position



Bike'N'Surf (Kit)

Bed construction adjustable in height:
 1. Bed height 710 mm / cargo height 510 mm
 2. Bed height 770 mm / Load. height 570 mm
 3. Bed height 810 mm / load. height 670 mm
 Slatted frame extendable (198 x 130 cm)
 complete incl. comfort upholstery w/ 11 cm thick mattress. Sleeping surface: 122/160x192 cm.
 Incl. Fastening material.

Info: For Volkswagen T6/T5 Multivan, Caravelle & Highline installation of bed is unfortunately not possible.

11004

1199,-



Kitchen module "Cooky"

Prefabricated part w/o. technology, prepared for optional cooling box CDF18. Decor Granitto (not available for long wheelbase)

11006

999,-



Cabinet suitable for VW T6.1/T6/T5 short wheelbase box & station wagon without second heat exchanger for use on the side of the bed. 1 compartment with hinged flap and adjustable shelf and 1 compartment with removable lid. approx. WxHxD 100 x131,2x39 cm. Decor Granitto.

110082

1020,-



Table system (Kit) Incl. Table base and table slide. Table top: approx. 84x46 cm. Decor Granitto, table edge silver.

11009

269,-



Curtains gray, translucent, including curtain track and glider, short wheelbase

19231

249,-

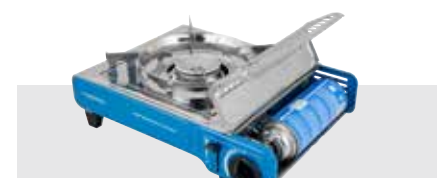

Cartridge stove Camp Bistro DLX

With safety lock system and piezo ignition. Power: 2200 W, dimensions: WxHxD 37x12x28cm. Weight: app. 1.9 kg

706474

64,99



Optional compressor cooler 18 liters
 DometicCDF1812/24 V

711490

479,-

REIMO FLORIDA KIT - VOLKSWAGEN T3

Based on Volkswagen Transporter T3, YOC. 1980 to 1990



The classic

- Florida kit for self-assembly
- Timeless and proven furnishing concept



Wood decor Granitto	Fabric decor New Wave Grey
------------------------	----------------------------------

Image examples, decors and upholstery may vary. Pictured technology not included.

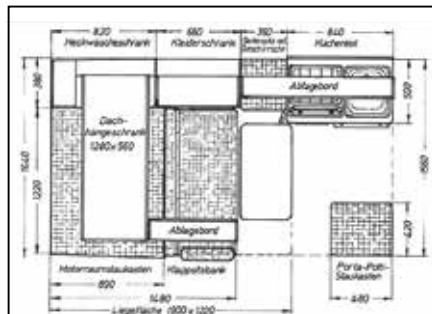
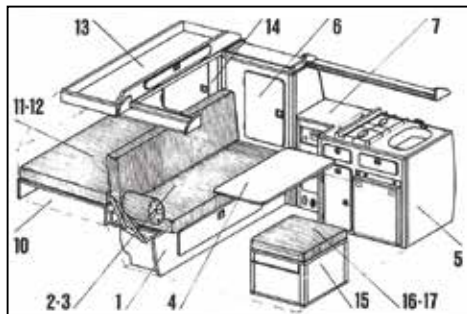

Simply retrofit your historic vehicle to ORIGINAL REIMO Florida or supplement the interior with original parts. Decor Granitto laminate. The wooden panels, doors, etc. are ready cut, you only need to assemble them. Lipping, hinges and furniture handles must be mounted

- Floor panel** Ship floor 10520 259,-
- 1 Upholstered folding bench**, rear narrow 13201015 529,-
- 2 Foam** for folding bench 13201120 159,95
- 3 Covers** New Wave Grey for folding bench narrow 13201227 309,-
- 4 Swivel table**, large and practical 13202015 209,-
- 5 Kitchen part**, wide, with drawer and Gas bottle compt., for compressor - Refrigerator CRX 65/711237 suitable.

(For 60 l absorber refrigerator 71351 customizable.) 13203015 559,-
Kitchen part with door, if no refrigerator is to be installed 13203115 649,-

- 6 Closet**, lateral with clothes rail 13204015 359,-
- 7 Crockery cabinet**, 1-door, with space for Reimo display panel 251 and heater 1800. 13211215 269,-
- 10 Engine compt. box** (height 13 cm) over entire width, rear center section removable. 13207015 329,-
- 11 Foam** (Mopo narrow for engine compartment) 13210020 149,-
- 12 Cover for Mopo** (New Wave Grey) 13210127 289,-
- 13 Hanging roof cabinet** with 1 mounting plate 13208115 329,-
- 14 Linen closet** in the rear with shelf 13205015 349,-

Vehicle dimensions

- Seats: 4
 - Length: 475 cm / width 185 cm
 - Height w/ HOD: 262 cm / SD 220 cm
 - Living room ht.: HOD 185 - 205 cmht.
 - Living room ht.: SD 218 - 236 cm
 - Weight: Empty 1900 kg / Total 2390 kg
 - Bed dims. below: 190 x 125 cm
 - top : HOD 210 x 120 / SD 185 x 112 cm
 - Refrigerator: 43 l or 60 l*
 - Heating : E2400*
 - Gas cylinders: 2x 5 kg*
 - Fresh water/waste water: 60 l/60 l*
- * Optional

15 Porta-Potti storage box

in special design (suitable for Porta-Potti 145/345) 13206015 269,-

16 Foam for Porta Potti storage box 13206120 44,95

17 Cover for PP storage box (New Wave Gray) 13206226 109,95

Side seat

for electronics heating or storage compt. 13208015 169,-

Cover for side seat (New Wave Grey) 13208226 119,-

Storage board Driver side 13212815 169,-

Recommended accessories

57 l compressor refrigerator CRX 65, with 7 l ice compt., 12 V/24 V 711237 949,-

REIMO SPEEDY KIT - VOLKSWAGEN T3

Based on Volkswagen Transporter T3, YOC. 1980 to 1990

The Speedy kit with Granitto surface Robust and proven

- Kit for self-assembly
- Great value for money
- Timeless and functional
- Shapely edges and furniture handles

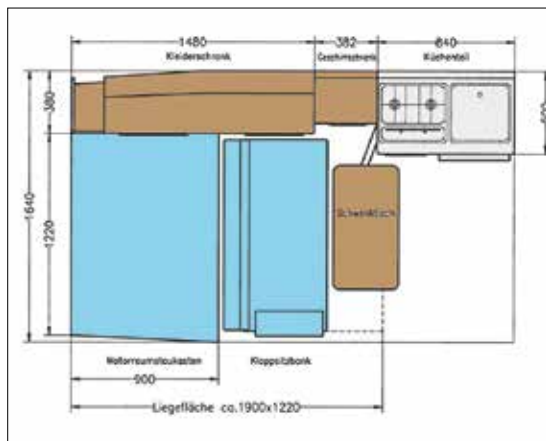

Devices are **not** included in the scope of delivery

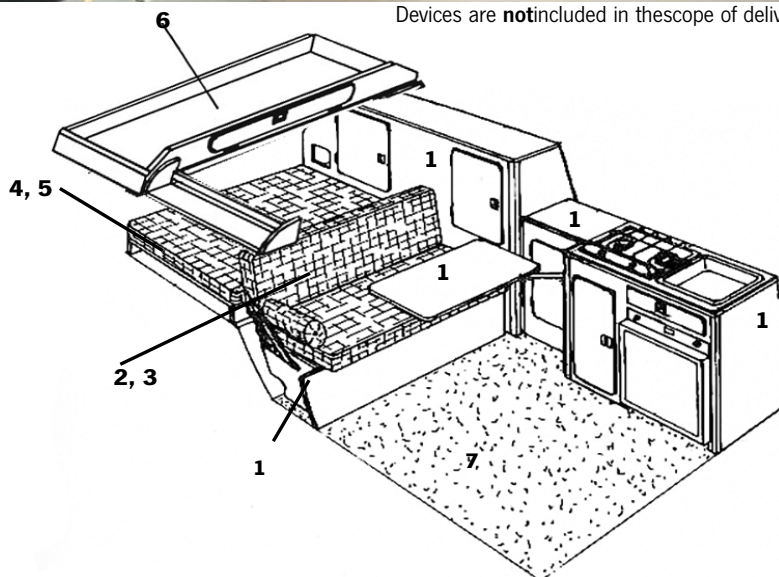

1 Speedy kit

Consists of table system, folding bench seat (without flap in front panel), closet combined with rear linen closet. Kitchen section with drawer, gas bottle compartment, upper end cover plate (without cutout; installation of stove and sink possible) and cutout for installation refrigerator. Crockery cupboard to left of kitchen section, 1-door, engine compartment storage box. Granitto laminate, lipping, hinges as well as furniture handles must be installed. (Folding bench seat without foam & covers) **13001 1799,-**

2 Foam for bench 13201120 159,95

3 Cover Classic bench,
gray, laminated, 3 mm(100% polyester)
13201227 309,-

4 Foam for the engine compartment
13210020 149,-

5 Classic engine compartment cover,
gray, laminated, 3 mm (100% polyester)
13210127 289,-

6 Hanging roof cabinet with flap, kit
13208115 329,-

7 Base plate
Ship floor **10520 259,-**



Granitto -T3/T4/T5/T6
Poplar plywood with 0.6 mm
HPL coating, both sides



Series fabric Classic Grey
100% polyester, 3 mm foam laminated

Tip: With our technology sets water system, 12 V/220 V system and gas system your Speedy setup will be complete. See accessories catalog

REIMO JOLLY KIT - VOLKSWAGEN T3

Based on Volkswagen Transporter 3, built between 1980 and 1989



Cheap camper kit for individual design.



- Camper-Kit for easy do-it-yourself installation
- Made from Natural wood for individual surface design
- Material: Natural multilayer poplar plywood
- The floor plan is similar to Florida`80/Speedy setup that has proven itself over many years

1 Jolly kit including table system and folding bench seat Complete kit for self-assembly. The wooden panels, doors, etc. are ready cut, you only need to assemble them. Hinges as well as furniture handles must be mounted. Show individuality with staining, glazing or varnishing. Of course, a bio-finish treatment is also possible. Kit untreated. (without foam, without cover)

130000 1299,-

2 Foam for folding bench

13201120 159,95

3 Cover for folding bench,

Design Classic gray, unquilted (100% polyester)

13201227 309,-

4 Foam for engine compartment

13210020 149,-

5 Classic engine compartment cover, gray, laminated, 3 mm (100% polyester)

13210127 289,-

6 Overhead cabinet

130001 229,-

7 Base plate

Ship floor

10520 259,-

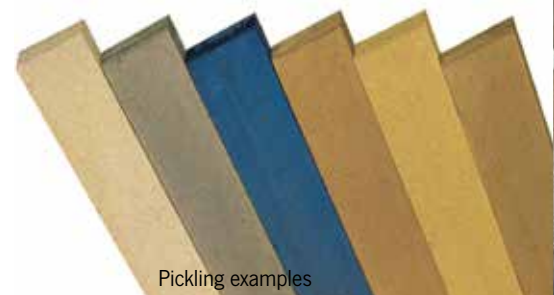
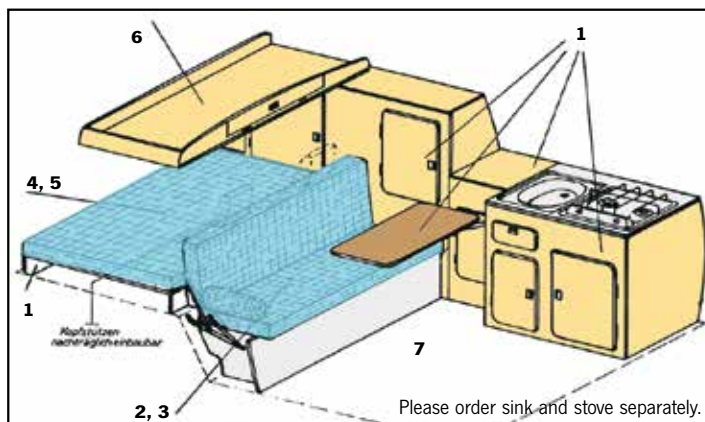
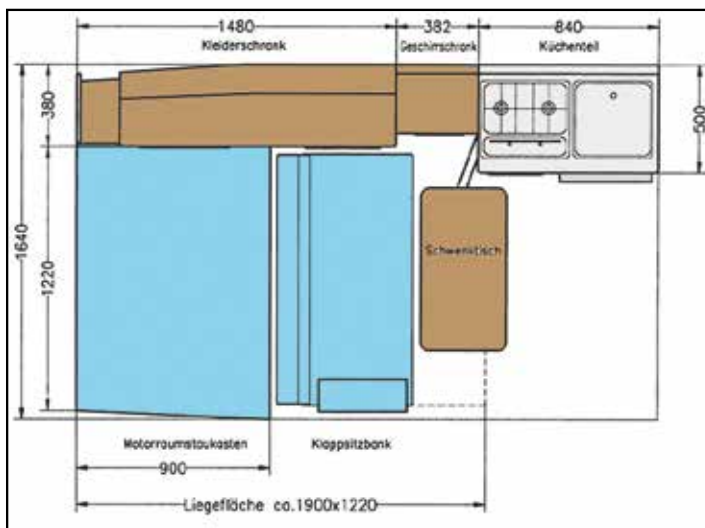

With REIMO
around the world
at home.
Since 1980.

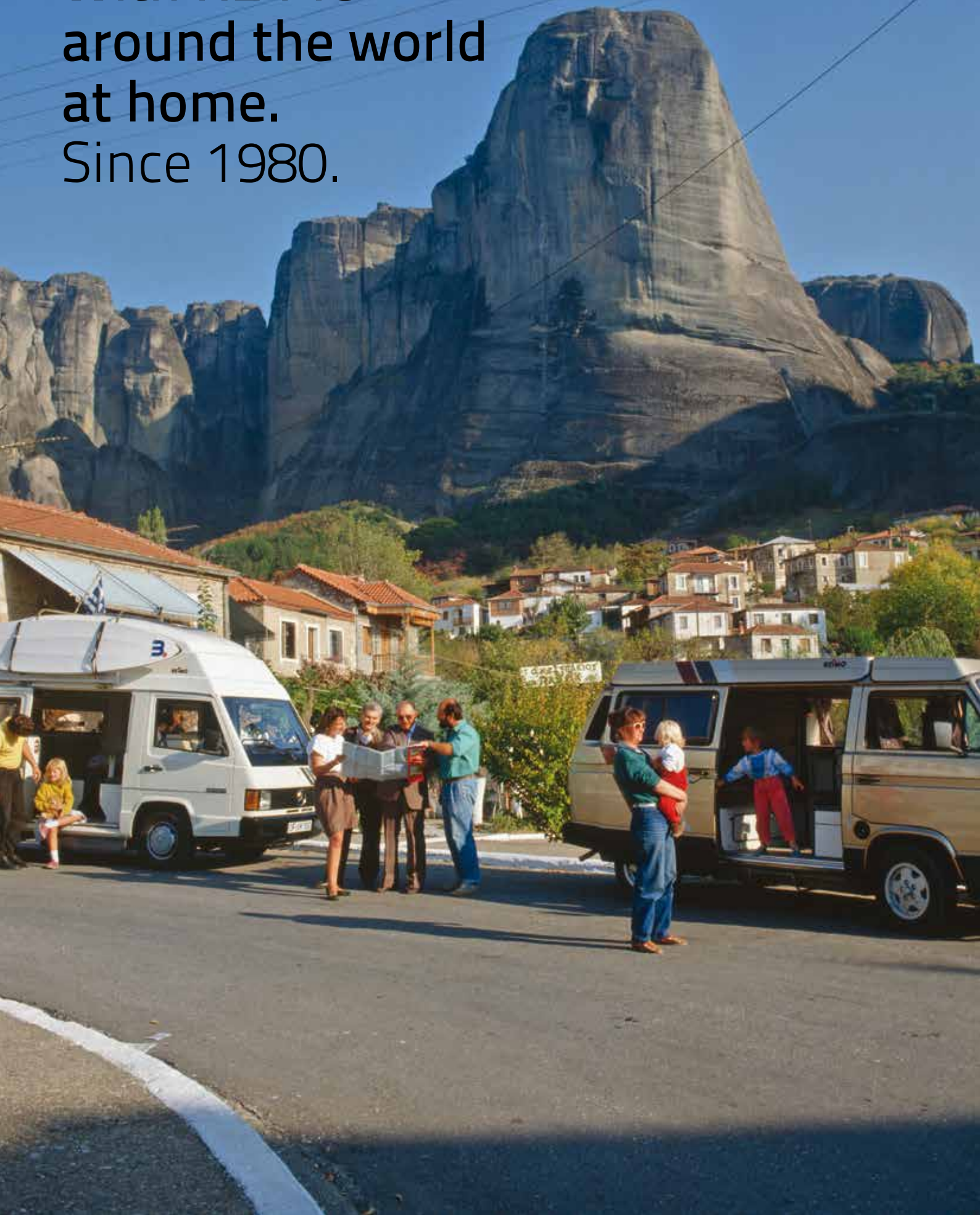



REIMO VAN-CONCEPT

MERCEDES-BENZ VITO

Exclusive camping conversions w/ multifunctional living and space concepts for Mercedes-Benz Vito.
Whether slim furniture line or fully equipped camper-Expansion - for individual leisure activity the right expansion concept.

-CONTENT-



REIMO LOFTVAN FOR MERCEDES-BENZ EQV VITO/V-CLASS	78-79
REIMO TRIOSTYLE FOR MERCEDES-BENZ VITO	80-81
REIMO CITYVAN FOR MERCEDES-BENZ VITO	82-83
REIMO WEEKENDER FOR MERCEDES-BENZ VITO	84-85

REIMO LOFTVAN - MERCEDES-BENZ EQV, V-CLASS, VITO

Kit for EQV, V-Class, Vito from YOC. 2014 with original Mercedes-Benz floor rails, length L2

Latest generation travel.

NEW

- Camping modules with elegant design
- Kitchen module & cooler mod. can be used independently of each other
- Maximum variability due to attachment to the original floor rails
- Seat/sleeper bench with integrated seat belts and headrests
- Maximum 6/7 seats possible

Technical specifications

Sleeps on sleeping/seating bench:	2
Sleeping berths w/ optional sleeping roof:	4
Light bed measure:	188x100 cm
Sleeping/sitting bench:	S2
Seats with three-point seat belts:	4
Stove:	1-burner gas cartridge stove*
Cooling unit:	Compressor cooler (26 l)*
Furniture making:	Poplar plywood Pearl, Black metallic

Fresh water / waste water:
1x 12 l canister / 1x 10 l canister*
*Included in the technology package

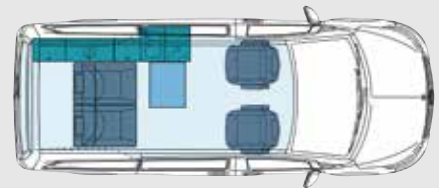

Day position



Night position



The flexible table system can be used inside and outside the vehicle.

In the 26 l compressor cooler even 1.5 l bottles can be stored upright.

Cooling box module with integrated storage compartment for the LithPowerUnit 48.



Furniture decor Pearl





Swivel consoles for driver's cab seats can be found from pg. 164 onwards



Multifunctional LithPowerUnit 48

The rechargeable PowerUnit 48 with 32 Ah LiFePO4 battery has multiple connection options for current draw for various end users. Connection options: 2x 230 V power socket, 2x 12 V (5.5 mm), 1x 12 V cigarette lighter socket, 2x USB, 1x USB QC, 1x USB-C. Rechargeable via 230 V mains, via 12 V car electrical system or solar panel. Integrated sine wave inverter, MPPT solar charge controller & batt. management system. Operation is carried out via clearly arranged LCD display. Robust housing and rubberized carrying handle. Scope of delivery: 230 V cable with Schuko plug, solar cable with 50 A high current connector, 12 V cable with cigarette lighter plug. Dims.: LxWxH 325x198x185 mm, weight: app. 8 kg.

814135

639,-



Kitchen module as a prefabricated part w/ mounted techn. package

In the kitchen module, table system is integrated in front module. The table system is supplied including a fold-down table base and can be hung on the already mounted table slide rails in the vehicle or outside on the kitchen module. Water system consists of sink, shower tap, 12 l fresh water canister and 10 l waste water canister and is already installed in the kitchen module. Behind the table top is storage compartment for 1-burner cartridge stove, and below it is a storage compartment for the cookware and kitchen utensils. Attachment of the kitchen module to the original floor rail in the Vitos and can be removed again in a few simple steps Decor: Pearl Black.

11700

999,-



Seat/sleeper bench S2

Offers maximum seating comfort thanks to ergonomic fit and high-quality molded foams and restful sleep thanks to completely flat sleeping surface. Integrated seat belts and headrest and Isofix mount per seat. Backrest and seat individually adjustable / foldable. Converted to sleeping bench in a few simple steps. Lying surface: app. 128x100 cm, incl. optional leg rest: app. 188x100 cm. The entire bench can be moved in the original rails and is completely removable. Cover: Anthracite.

59656

2790,-

You can find mobile solar systems at www.reimo.com

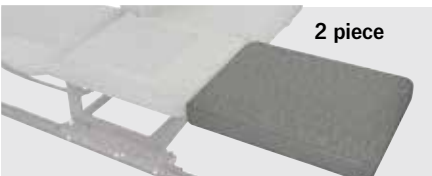

2 piece

Leg rests, 2 pieces

To extend the sleeping surface by about 60 cm. Can be stowed underneath the seat when not in use. Approx. dimensions: 50x60 cm. Cover: Anthracite.

59657

879,-



Cooling box module as prefabricated part w/ assembled techn. package

Cooler module is equipped with 26 l compressor cooler as well as storage compt. for the LithPowerUnit 48 & another storage compartment for vacation luggage. The module is attached to the original floor rail of the Vitos and can be removed in a few simple steps. Décor: Pearl Black.

11701

1699,-



Curtain set, Mercedes-Benz V-Class

For 2 sliding doors and tailgate with window to open. Living room curtains guided in rails above and below. Driver's cab w/ push buttons.

19246

448,-



Sleeping/seating bench adapter for Mercedes-Benz EQV, V-Class, Vito

To convert the sleeping/seating bench to the original Mercedes-Benz Vito bench rails.

59659

534,-



Cartridge stove Camp Bistro DLX

With safety lock system and piezo ignition. Power: 2200 W, dims.: W37xD28xH12 cm, weight: app. 1.9 kg.

706474

64,99

REIMO TRIOSTYLE - MERCEDES-BENZ VITO

Based on Mercedes-Benz Vito long estate (length 514 cm) from YOC. 8/2014

Five stars on wheels.

- Exclusive camping full equipment
- 5 three-point seatbelts allow driving with 5 people (up to 7 people with optional individual seats)
- Ample storage space in rear as well as under bench
- Seat sliding and easily removable
- Swivel work / dining table
- Easily accessible water/wastewater canisters in the stern



A clever expansion highlight is the storage flap, which is integrated into underside of bed. It allows quick access to travel utensils and luggage in the trunk from inside the vehicle when the bench seat is converted into a sleeper bench.

This means you don't necessarily have to leave the vehicle, which is especially handy in bad weather.

For further equipment and options, please contact your specialist dealer. Fig. partly show optional equipment that is not incl. in scope of delivery.

Technical specifications

Sleeps on sleeping/seating bench:	2
Sleeping berths w/ optional sleeping roof:	4
Bed size sleeping roof:	200x120 cm
Light bed measure:	198x132 cm sleeping/ seating bench: Variotech® 3000
Seats with three-point seat belts:	5
Stove:	2-burner gas stove*
Cooling unit:	Compressor refrigerator (39 l)*
Gas capacity:	Space for 2x 5 kg gas bottle
furniture constr.:	Poplar plywood with HPL laminated and postforming edges
Fresh water / waste water:	2x 12 / 27 liters*
Closet:	ca. 57 x 24 x 82 cm / ca.112 liters

Tall cabinet:	117 x 126 x 33 cm
Overhead cabinet:	97x36 x9 cm / app. 32 l
Rear storage space	
- with / without bench:	2700 l / 4100 l
- under bed extension:	WxHxD 112x37x63 cm
- under the bench:	65 x 55 x 26 cm / 93 l

*Incl. in techn. package

Payload example:

Base vehicle Mercedes-Benz Vito long "Tourer Base	
Total permissible mass:	3050 kg
Payload w/o. sleeping roof:	app. 840 kg
payload w/ sleeping roof:	app. 770 kg



Day position

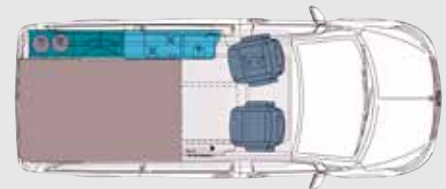

Night position





Sleeping/seating bench Variotech® 3000

Three-seater, Gr. 8 Total width: 1155 mm, cushion width: 1100 mm, sleeping surface: 1980x1320 mm. 3 integrated, retractable head restraints, 3 seat belts, Isofix attachment points for a max. of 2 child seats (middle seat cannot be used when using a child seat), fold-up rear cushion Rear cushion (storage space height under rear cushion: 42 cm, storage space height under seat bench: 31 cm), w/ side panel. Ready upholstered incl. rear cushion. Bench sliding and removable. Rail spacing 700 mm. Fabric design: Classic gray, 2-tone.

5045000 4390,-

"Grizzly" slide rail set

2 aluminum slide rails, silver anodized for Vito long. Length: 2540 mm, 4 different driving positions.

58326 529,-

Floor adaptation made of steel

Prescribed for installation of slide rail.

Right type 1 **58327 239,-**

Center type 2 **583271 289,-**

Fastening kit

For fastening the slide rails to the vehicle floor. Rail spacing 700 mm (Vito long).

58328 339,90



1 Drawer optionally available

Provides additional storage space for e.g. shoes, cables or on-board tools. The drawer can be removed for loading long parts. Dims.: WxHxD: app. 49,5x17x69,5 cm. Décor: Basalt

5045090 679,-

2 Front panel optionally available

Mounting is made on the bench instead of a drawer. Front panel is removable and therefore offers a through-loading option for e.g. surfboard or skis up to a maximum length of 2.4 m. (Loading dimensions under the bench: WxH app. 60x31 cm. Décor: Basalt

5045080 249,-



Base plate 3-piece.

made of waterproof chipboard w/ PVC covering. For MB Vito (long). Rail spacing 700 mm Décor: ship's bottom

16807 449,-

X-Trem insulator, 15 mm thickness

Extremely heat insulating & very light insulation. Needed under the base plate. Supplied as panels with a 2 x 1 m. (3x for SWB)

50009 29,20



Furniture unit as finished part w/o. tech. package

Chic furniture part incl. tall cabinet w/ sliding door, linen compt., storage compartment for 2x 5 kg gas bottles. 2 drawers. A roller blind-cabinet offers plenty of space (e.g. forhem. Porta-Potti Qube 335 chem. toilet, 660102). Cutouts for laying gas, water, hot air and electric are already made. Furniture line w/o. technology, appliances & inst. Décor: White laminate.

15081 2899,-



Technology package-in above furniture line installed

Technical package includes: Sink-stove combination w/ glass cover, 2x 12 l fresh water canister, 27 l waste water canister, water tap, submersible pump 18 l & hoses, compressor refrigerator (Dometic CRP 40, app. 39 l), gas system prepared for 2x 5 kg gas bottle. 12 V/230 V system with Reimo fuse panel 714, Carbest switch-mode charger 15 A, circuit breaker 13 A with Fi, CEE input socket and connection parts. 24 LED aluminum line light in kitchen part.

191005E 3999,-



Truma gas heater VarioHeat eco

Built in furniture unit, incl. fireplace. Opening for chimney as well as the chimney still have to be attached to the vehicle.

720304E 2529,-



Table system with swivel table frame

multifunction table with integrated table frame in the bottom. It allows the table to be placed outside the vehicle and thus also serves as a camping table. Table top ca. 85x47 cm, material: laminate. Table decor: Pearl, silver table edge. Delivery includes stainless steel swivel table frame for mounting on the front panel of the bench.

10694S 679,-



Overhead locker

As a prefabricated part above the rear bench seat for additional storage space. Cabinet pre-assembled. Only in combination with sleeping roof. Décor: Apple laminate.

15082 449,-



Post. camping toilet Porta Potti 335

Suitable for furniture line. High quality plastic for maximum hygiene.

660102 149,-

REIMO CITYVAN - MERCEDES-BENZ VITO

Based on Mercedes-Benz Vito long estate (length 514 cm) from YOC. 8/2014

True multifunctional mobile.

- Multifunctional driving pleasure in perfection with extensive standard equipment for high demands.
- The generous space concept and the convertibility open up limitless possibilities.



Technical specs.

REIMO CityVan short wheelbase:

Sleeps on sleeping/seating bench:	2 - 4
Sleeping berths w/ sleeping roof:	4
Bed size sleeping roof:	200x120 cm
Light bed measure:	198x140 cm sleeping/ seating bench: Variotech® 3000
Seats with three-point seat belts:	5 - 6
Stove:	1-Flame gas, or spirit
Cooling unit:	Compressor cooler (26 l)
furniture constr.:	Poplar plywood with HPL laminated and postforming edges
Fresh water / waste water:	13 l / 13 l
Closet:	app. 57 x 24 x 82 cm / app. 112 l
Overhead cabinet:	123 x 27 x 11 cm / app. 36 l
Rear storage space	
- with / without bench:	2900 l / 4400 l
- under bed extension:	WxHxD 121x37x60 cm
- under the bench:	60 x 31 cm
through-loading option:	2,4 m

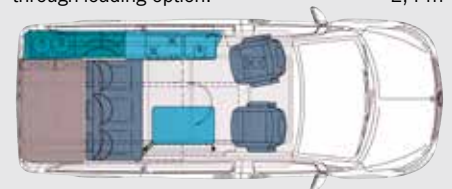

Day position

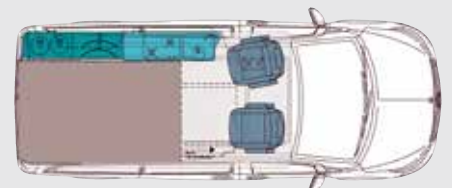

Night position



For further equipment and options please contact
Your specialist dealer. Fig. show partly special equipment,
which are not included in scope of delivery.





Sleeping/seating bench Variotech® 3000

Three-seater, Gr. 14, total width: 1305 mm. Upholstery width: 1250 mm, sleeping surface: 1980x1400 mm.

3 integrated retractable headrests, 3 seat belts, Isofix attachment points for a maximum of 2 child seats (middle seat cannot be used when a child seat is used), fold-up rear upholstery (storage height under rear upholstery: 46 cm), side panel. Ready upholstered incl. rear cushion. Bench sliding and removable. Rail spacing 1050 mm.

Fabric design: Classic gray, 2-tone.

5045000 4390,-

Slide rail set "Grizzly"

2 aluminum slide rails, silver anodized for Vito long. Length: 2540 mm, 4 different driving positions.

58326 529,-

Floor adapter for steel

For slide rail set "Grizzly" for long wheelbase. For fastening the slide rails to the vehicle floor. Rail spacing 1050 mm.

Right type 1 **58327 239,-**

Center type 2 **583271 289,-**

Fastening set For slide rail set "Grizzly" for short wheelbase. For fastening the slide rails to the vehicle floor. Rail spacing 1050 mm

58328 339,90



1 Drawer

Provides additional storage space for e.g. shoes, cables or board tools. The drawer can be removed for loading long parts. Dims. WxHxD: app. 66,5x17x69,5 cm. Décor: Basalt

5045090 679,-

2 Front panel

Mounting is made on the bench instead of a drawer. Front panel is removable and therefore offers a through-loading option for e.g. surfboard or skis up to a maximum length of 2.4 m. (Loading dims. unde bench: WxH app. 75x31 cm. Décor: Basalt

5045080 249,-



Base plate 3-piece .

made of waterproof chipboard w/ PVC covering. Rail spacing 1050. For MB VITO Décor: ship's bottom

168071 449,-

X-Trem insulator, 18 mm thickness

Extremely heat insulating & very light insulation. Is needed under the base plate 3x for LWB. Supplied as panels with a 2 x 1 m.

50009 29,20



Furniture line as a finished part w/o.

technical pack. Elegant furn. part w/ cover flaps. Prepared for installation of water system, compact sink and cooler box.

Series decor:high gloss anthracite-silver.

15083 2989,-



Tech. package inst.above furniture line

Water system consisting of: Stainless steel basin 325 x 176 mm, automatic water tap, 2x 13-liter canister, submersible pump, 12 V connection parts, water hose (10 and 19 mm), & small parts. Slim cooler with plenty of space and only about 200 mm deep. Temperature range from +1° C to 10° C. External cooling unit, Danfoss BD 2.5 compressor.

Dims.: app. WxHx 50x36x20 cm Weight app. 18.9 kg. built in.

Water systems **60004E 399,-**

Water systems with fuse channel 713

60004EE 699,-

Compressor cooler 26 l **71177E 1319,-**



Cartridge stove Camp Bistro DLX

With safety lock system and piezo ignition. Power: 2200 W, dims.: WxHxD 37x12x28x12 cm, Weight: app. 1,9 kg

706474 64,99



Diesel parking heater Carbest VanHeat 2.0-DH

For mounting under passenger seat, power 2 kW, incl. alt. kit up to 5,000 m and digital control panel. Incl. Tank removal set and extensive mounting material.

48182 649,-

Mounting bracket under front passenger seat **481821 49,95**

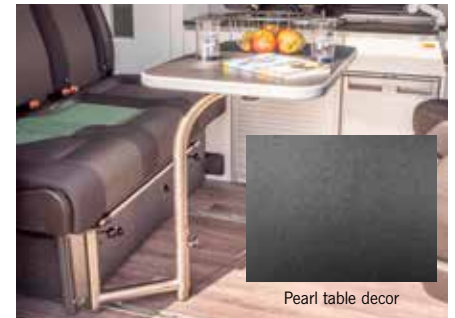

Pearl table decor

Table system with swivel table frame

multifunction table with integrated table frame in the bottom. It allows the table to be placed outside the vehicle and thus serves as a camping table. Table top ca. 85x47 cm, material: laminate. Table decor: Pearl, silver table edge. Delivery includes stainless steel swivel table frame for mounting on the front panel of the bench.

10694S 679,-



Hanging roof cupboard for Easy Fit sleeping

roof w/ slatted bed As prefabricated part above rear bench seat for add. storage space. Cabinet pre-assembled. For short or long wheelbase with decor: high-gloss anthracite-silver.

15085 459,-



Porta-Potti Box

made of HPL laminate with upholstered pad. (Without toilet) Decor: Anthracite silver

10696 839,-

Portable camping toilet Porta Potti 335

Suitable for Porta Potti kit. High quality plastic for maximum hygiene.

660102 149,-

REIMO WEEKENDER - MERCEDES-BENZ VITO

Based on Mercedes-Benz Vito long estate (length 514 cm) from YOC. 8/2014

Large capacity van for up to 5 people.

- Large flat sleeping surface over entire inner width with high lying comfort - without disturbing seams or straps
- Sliding and removable 3-person bench seat with integrated 3-point seat belts as well as retractable headrests and Isofix mounts for 2 child seats
- Through-loading option for long parts when removing the drawer or front panel



Whether for business, everyday life or leisure - the REIMO Weekender is the perfect first vehicle for any occasion.

All-rounder Weekender is large-capacity sedan for everyday & professional use, w/ plenty of room for passengers to move around & ample storage space in rear.

In spare time it becomes with the optional kitchen block the perfect travel companion with 2 - 4 full sleeping places (sleeping roof optional).



For further equipment and options please contact Your specialist dealer. Fig. show partly special equipment, which are not included in scope of delivery.

Technical specs.:

Sleeps on sleeping/seating bench:	2-4
Sleeping berths w/ optional sleeping roof:	4
Light bed size with storage box:	198x140 cm
Bed size sleeping roof:	200x120 cm
sleeping/sitting bench:	Variotech® 3000
Seats with three-point seat belts:	5
Rear storage space	
- with / without bench:	3400 l / 5200 l
- under bed extension:	WxHxD 126x37x60 cm

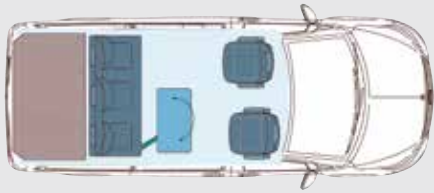

Day position



Night position



Sleeping/seating bench Variotech® 3000

For vehicles w/o. sideways . Plastic cladding. Three-seater, Gr. 17, total width bench: 1380 mm. Upholstery width: 1330 mm, sleeping surface: approx. 1980x1600 mm. 3 integrated retractable headrests, seat belts. Isofix attachm. points for max. 2 child seats (middle seat not usable when using a child seat), fold-up rear upholstery (storage space height under rear upholstery: 2 cm) Rear cushion (storage space height under rear cushion: 46 cm), front panel & side panel. Ready upholstered incl. rear cushion. Bench sliding and removable. Rail spacing 1050 mm. Fabric design: Classic gray, 2-tone.

5045100 4590,-

Slide rail set "Grizzly"

For Variotech® 3000. Length: 2540 mm.

58326 529,-

Floor adaptation steel

for rail spacing 1050 mm

58327 239,-

Fastening set

For slide rail set "Grizzly" for short wheelbase. For fastening the slide rails to the vehicle floor. Rail spacing 1050 mm.

583282 185,90



1 Drawer

Provides additional storage space for e.g. shoes, cables or on-board tools. The drawer can be removed for loading long parts. Dims. WxHxD: app. 83,5x17x69,5 cm. Décor: Basalt

5045190 679,-

2 Front panel

Mounting is made on the bench instead of a drawer. Front panel is removable and therefore offers a through-loading option for e.g. surfboard or skis up to a maximum length of 2.4 m. (Loading dimensions under the bench: WxH app. 60x31 cm. Décor: Basalt

5045180 249,-



Base plate 3-piece.

made of waterproof chipboard w/ PVC covering. For original Mercedes-Benz Vito sill trim Décor: ship bottom

168071 449,-

X-Trem insulator, 18 mm thickness.

Extremely heat insulating & very light insulation. Is needed under the floor panel 3x for long wheelbase. Supplied as panels of 2 x 1 m each.

50009 29,20



Diesel parking heater Carbest VanHeat 2.0-DH

For mounting under passenger seat, power 2 kW, incl. alt. kit up to 5,000 m and digital control panel. Incl. Tank removal set and extensive mounting material.

48182 649,-

Mounting bracket under front passenger seat
481821 49,95

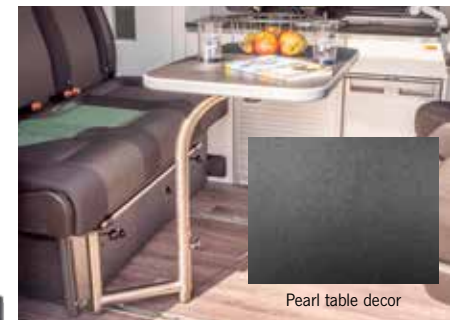

Pearl table decor

Table system with swivel table frame

multifunction table with integrated table frame in the bottom. It allows the table to be placed outside the vehicle and thus serves as a camping table. Table top ca. 85x47 cm, material: laminate. Table decor: Pearl, silver table edge. Delivery includes stainless steel swivel table frame for mounting on the front panel of the bench.

10694S 679,-



Hanging roof cupboard for Easy Fit sleeping roof w/ slatted bed As prefabricated part above rear bench seat for add. storage space. Cabinet pre-assembled. For long wheelbase with decor: apple laminate.

15085 459,-

REIMO VAN-CONCEPT

RENAULT TRAFIC OPEL VIVARO FIAT TALENTO NISSAN NV 300

The REIMO TrioStyle camping equipment for Renault, Opel, Fiat and Nissan leaves nothing to be desired on vacation or in your free time.

Exclusive furniture line w/ full equipment & plenty of storage space offers highest comfort for individual vacation trips.

The large sleeping area, which extends over the entire width of the vehicle, guarantees best sleeping comfort on the road.



-CONTENT-

REIMO TRIOSTYLE	88-89
REIMO WEEKENDER	90-91



REIMO TRIOSTYLE - RENAULT/FIAT/NISSAN/OPEL

Based on Renault Trafic/Fiat Talento/Nissan NV300 (SWB) from YOC. 7/2014/ Opel Vivaro B Station Wagon until YOC. 3/2019

Travel without compromise.

- The exclusive camper with full equipment and chic furniture line
- For up to 7 passengers, with two additional individual seats (all seats with three-point seat belts)
- Rample storage space in the rear thanks to sliding and removable sleeper/seat bench



Sleeping/seating bench for 3 persons. Exclusive kitchenette with all comforts: large 40 L compressor refrigerator, closet with linen compartment, storage compartment, suitable for portable camping toilet, swivel work and dining table.



For further equipment and options, please contact your specialist dealer. Equipment for the long wheelbase can be found at: www.reimo.com. Fig. partly show opt. equipment not included in scope of delivery.



Technical specifications REIMO TrioStyle SWB:

Sleeps on sleeping/seating bench:	2
Sleeping berths with optional sleeping roof:	4
Light bed measure:	200 x 125 cm
Dim. roof bed:	187 x 140 cm
Sleeping/sitting bench:	Variotech@ 3000
Seats with three-point seat belts:	5
Stove:	2-burner gas stove
Cooling unit:	Dometic CRP 40 compressor refrigerator (app. 39 l)* Gas capacity:
Space for 2x 5 kg gas bottle furniture constr.:	Poplar plywood with HPL laminate
Fresh water / waste water:	2x 12 l / 43 l
tall unit:	104 x 127 x 38 cm
Overhead cabinet:	123 x 27 x 11 cm / app. 36 l
Rear storage space	
- with / without bench:	2260 l / 3950 l
- under bed extension:	WxHxD 106x40x65 cm
- under the bench:	75x28x43 cm / 90 l
	*incl. in technology package

Total permissible mass:	2700 kg
payload without sleeping roof:	app. 380 kg
payload w/ sleeping roof:	app. 320 kg

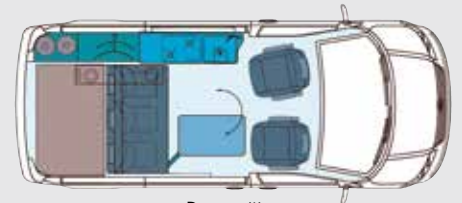

Day position

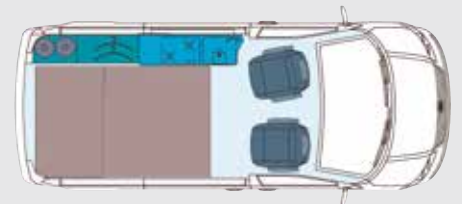

Night position





Sleeping/seating bench Variotech® 3000

Three-seater, Gr. 10 Total width: 1205 mm, cushion width: 1150 mm, sleeping surface: 1960x1210 mm. 3 integrated, retractable head restraints, 3 seat belts, Isofix attachment points for a maximum of 2 child seats (middle seat cannot be used when using a child seat), fold-up rear cushion (storage space height under rear cushion: 46 cm), 1 side panel. Ready upholstered incl. rear cushion. Bench sliding and removable. Rail spacing 673 mm. Fabric design: Classic gray, 2-tone.

5044000 4440,-

"Grizzly" glide bar set

For Variotech® 3000. Length: 2489 mm.

58128 499,-

Bottom reinforcement, steel 1-piece.

Prescribed for installation of floor rail. Short/Long wheelbase.

581251 Front 229,-

581252A Rear 389,90

Fastening set

For slide rail set "Grizzly" for short wheelbase. For fastening the slide rails to the vehicle floor. Rail spacing 673 mm.

58133 218,90



1 Drawer

Provides add. storage space for e.g. shoes, cables or on-board tools. The drawer can be removed for loading long parts. Dims. WxHxD: app. 49,5x17x69,5 cm. Décor: Basalt

5044090 679,-

2 Front panel

Mounting is made on the bench instead of a drawer. The front panel is removable & therefore offers a through-loading option for e.g. surfboard or skis up to a maximum length of 2.4 m. (Load-through dims. under bench:

WxH app.. 31x60x31 cm. Décor: Basalt

5044080 249,-



Base plate 3-piece .

made of waterproof chipboard w/ PVC covering. For Renault Trafic etc... 673 mm rail spacing Décor: ship's bottom

141142 459,-

X-Trem insulator, 18 mm thickness

Extremely heat insulating & very light insulation. Is needed under the base plate, 2x for SWB. Supplied as panels of 2 x 1 m each.

50009 29,20

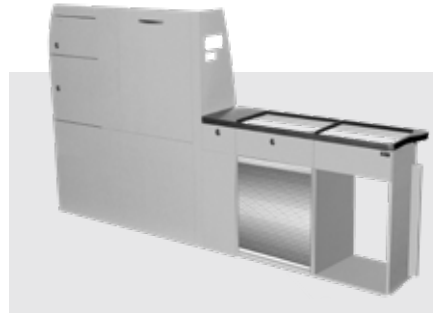

Furniture unit as prefabricated part, w/o. techn. package

Excl. furniture unit w/ full-length front in apple decor. Large closet w/ sliding door, linen comp. & storage compartment for 2x 5 kg gas bottles. With 2 drawers & a roller cabinet, kitchen section offers you space for Porta-Potti Qube 335 (660102) chemical toilet, as well as plenty of room for provisions and equipment. Recesses for the installation of gas, water, hot air, electricity and other installation preparations have already been made. Decor furniture line: Laminate high gloss silver.

16050 3799,-



Technical package includes:

Sink-stove combination with glass cover, 2x 12 l fresh water canister, 27 l waste water canister, water tap, submersible pump 18 l and hoses, compressor refrigerator (Dometic CRP 40, approx. 39 l), gas system prepared for 2x 5 kg gas bottle. 12 V/230 V system with Reimo fuse panel 714, Carbest switch-mode charger 15 A, circuit breaker 13 A with FI, CEE input socket and connection parts. 24 LED aluminum line light in kitchen part.

191005E 3999,-



Truma gas heater VarioHeat eco

Built in furniture unit, incl. fireplace. Opening for chimney as well as the chimney still have to be attached to the vehicle.

720304E 2529,-

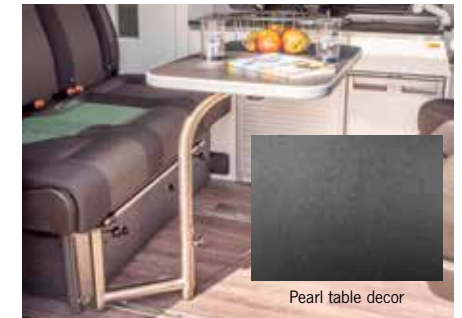

Table system with swivel table frame

multifunction table with integrated table frame in the bottom. It allows the table to be placed outside the vehicle and thus serves as a camping table. Table top ca. 85x47 cm, material: laminate. Table decor: Pearl, silver table edge. Delivery includes stainless steel swivel table frame for mounting on the front panel of the bench.

10694S 679,-



Hanging roof cupboard for Easy Fit sleeping roof w/ slatted bed As prefabricated part above rear bench seat for add. storage space. Cabinet pre-assembled. For short or long wheelbase with decor: laminate, high-gloss silver.

160547 479,-



Portable camping toilet Porta Potti 335

Suitable for TrioLoft furniture line. High quality plastic for maximum hygiene.

660102 149,-

REIMO WEEKENDER - RENAULT/FIAT/NISSAN/OPEL

Based on Renault Trafic/Fiat Talento/Nissan NV300 (SWB) from YOC. 7/2014 Opel Vivaro B Kombi until YOC. 3/2019

Large capacity van for up to 5 people.

- Large flat sleeping surface over entire inner width w/ high lying comfort - without disturbing seams or straps
- Sliding and removable 3-person bench seat with integrated 3-point seat belts as well as retractable headrests and Isofix mounts for 2 child seats
- Loading option for long parts when removing the drawer or front panel



Whether for business, everyday life or leisure - the REIMO Weekender is the perfect first vehicle for any occasion.

REIMO Weekender is a large-capacity all-rounder sedan for everyday & professional use, w/ plenty of room for passengers to move around & ample storage space in rear.

In the spare time it becomes w/ optional kitchen block the perfect travel companion with 2 - 4 full sleeping places (sleeping roof optional).



Please ask for further equipment and options at your specialist dealer. Fig. show partially special-equipment that are not incl. in scope of delivery.



Technical specifications REIMO Weekender:

Sleeps on sleeping/seating bench:	2
Sleeping berths with optional sleeping roof:	4
Bed size sleeping roof:	187x140 cm
Light bed measure:	200 x160 cm sleeping/ sitting bench: Variotech® 3000
Seats with three-point seat belts:	5
Rear storage space	
- with / without bench:	3000 l / 5000 l
- under bed extension:	DxWxH 65x126x40 cm

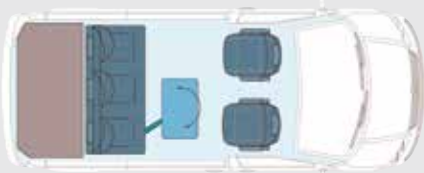

Day position



Night position



Sleeping/seating bench Variotech® 3000

For vehicles w/o. sideways. Plastic cladding. Three-seater, Gr. 17, total width bench: 1380 mm. Upholstery width: 1330 mm, sleeping surface: app. 1960x1600 mm. 3 integrated retractable headrests, seat belts. Isofix attachment points for max. 2 child seats (middle seat not usable when using a child seat), fold-up Rear cushion (storage space height under rear cushion: 46 cm), front & side panel. Ready upholstered incl. rear cushion. Bench sliding and removable. Rail spacing 1020 mm. Fabric design: Classic gray, 2-tone.

5044300 4390,-

"Grizzly" glide bar set

For Variotech® 3000. Length: 2489 mm.

581280 499,-

Fastening set

For slide rail set "Grizzly" for short wheelbase. For fastening the slide rails to the vehicle floor. Rail spacing 1020 mm.

58135 244,-



1 Drawer

Provides add. storage space for e.g. shoes, cables or on-board tools. The drawer can be removed for loading long parts. Dims. WxHxD: app. 83,5x17x69,5 cm. Décor: Basalt

5044390 679,-

2 Front panel

Mounting is made on the bench instead of a drawer. Front panel is removable and therefore offers a through-loading option for e.g. surfboard or skis up to a maximum length of 2.4 m. (Loading dimensions under the bench: WxH app. 60x31 cm. Décor: Basalt

5044380 249,-



Base plate 3-piece .

made of waterproof chipboard w/ PVC covering. For original TRAFIC & others 1020 mm rail spacing Décor: ship's bottom

141146 459,-

X-Trem insulator, 18 mm thickness

Extremely heat insulating & very light insulation. Is needed under the base plate, 2x for SWB. Supplied as panels with a 2 x 1 m.

50009 29,20



Pearl table decor.

Table system with swivel table frame

multifunction table with integrated table frame in the bottom. It allows the table to be placed outside the vehicle and thus also serves as a camping table. Table top ca. 85x47 cm, material: laminate. Table decor: Pearl, silver table edge. Delivery includes stainless steel swivel table frame for mounting on the front panel of the bench.

10694S 679,-



REIMO VAN-CONCEPT

FORD TRANSIT CUSTOM

The comfort camper with plenty of space.

Thanks to its wider interior compared to similar models in its vehicle class, Ford Transit Custom offers noticeably more living space in the vehicle.

In combination with REIMO TrioStyle camping equipment, your individual camping dream vacations are guaranteed even before you start your trip.

▪ CONTENT ▪

REIMO TRIOSTYLE FOR FORD TRANSIT CUSTOM94-95

REIMO TRIOSTYLE - FORD TRANSIT

Based on Ford Transit Custom, SWB station wagon (L1/H1) + flat roof, YOC. 2013-2022

Five stars on wheels.

- Exclusive camping full equipment
- 5 three-point seatbelts allow driving with 5 persons (up to 6 persons with optional single seat)
- Ample storage space in rear as well as under bench
- Seat sliding and easily removable
- Swivel work / dining table
- Easily accessible water/wastewater canisters in stern



A clever expansion highlight is storage flap, which is integrated into underside of the bed. It allows quick access to travel utensils and luggage in the trunk from inside the vehicle when the bench seat is converted into a sleeper bench.

This means you don't necessarily have to leave the vehicle, which is especially handy in bad weather.



Sideboard as bed widening optionally available (see right side - 50420M)



Sleeping/sitting bench for 2/3 persons. Kitchen with all comforts: refrigerator*, large closet with linen compartment and swivel work and dining table.

Technical specifications

Sleeps on sleeping/seating bench:	2
Sleeping berths with optional sleeping roof:	4
Light bed measure:	209x134 cm
Bed size sleeping roof:	202x130 cm
Sleeping/sitting bench: Variotech®	3000
Seats with three-point seat belts:	5
Stove:	2-burner gas stove*
Cooling unit:	Compressor refrigerator Dometic CRP 40 (39 l)*
Gas capacity:	Space for 2x 5 kg gas bottle
furniture constr.:	Poplar plywood with HPL laminate and postforming edges
Fresh water / waste water:	2x 12 liters*
Closet:	ca. 57x82x24 cm / ca.112 liters

Tall cabinet:	58 x120/82x26/20 cm / 120 l
Overhead cabinet:	97x36x9 cm / app. 32 l
Rear storage space	
- with / without bench:	2700 l / 4200 l
- under bed extension:	WxHxD 115x40x61 cm
- under the bench:	75x28x43 cm / 90 l

*Incl. in technology package

Total permissible mass:	3000 kg
payload without sleeping roof:	app. 598 kg
payload w/ sleeping roof:	app. 543 kg

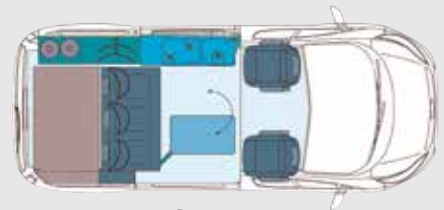

Day position

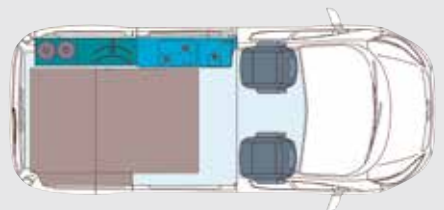

Night position



For further equipment and options please contact Your specialist dealer. Fig. show partly special equipment, which are not incl. in scope of delivery.



Sleeping/seating bench Variotech® 3000

Three-seater, Gr. 10, total width: 1205 mm, upholstery width: 1150 mm, sleeping surface app. 2020x1340 mm. 3 integrated retractable headrests. 3 seat belts, Isofix attachment points for a maximum of 2 child seats for the outer seats (middle seat cannot be used when using a child seat), fold-up rear cushion (storage space height under rear cushion: 46 cm), side panel. Ready upholstered incl. rear cushion. Bench slidable and removable. Rail spacing 766 mm. Fabric design: Classic gray, 2-tone.

5042000 4440,-

Inclusive "Grizzly" slide rail set

2 aluminum slide rails, Silver anodized for Ford Transit Custom. Length: 2860 mm, 4 different driving positions.

581960 569,-

Steel floor adapter 4-piece.

For installation of the slide rail prescribed with screw set.

58193 515,90



1 Drawer

Provides additional storage space for e.g. shoes, cables or on-board tools. The drawer can be removed for loading long parts. Dims. HxWxD: app. 17x49,5x69,5 cm. Décor: Basalt

5042090 679,-

2 Front panel

Mounting is made on the bench instead of a drawer. Front panel is removable and therefore offers a through-loading option for e.g. surfboard or skis up to a maximum length of 2.4 m. (Loading dimensions under the bench: WxH app. 60x31 cm. Décor: Basalt

5042080 249,-



Base plate 3-piece.

made of waterproof chipboard w/ PVC covering. Rail spacing: 766 mm. For Ford Custom short wheelbase. Décor: ship's bottom

105230 419,-

Including base plate insulation. X-Trem insulator, 18 mm thickness.

Extremely heat insulating & very light insulation. Needed under the base plate. Plate size 2 x 1 m. (You need 3 plates). 1 pc.

50009 29,20



Furniture unit as prefabricated part w/o. technical package

Chic furniture part w/ large closet w/ sliding door, linen compartment & storage comp. for 2x 5 kg gas bottles. Kitchen section offers space for Porta-Potti Qube 335 chemical toilet with 2 drawers and a tambour cabinet (660102), as well as plenty of space for provisions and equipment. Cutouts for laying gas, water, hot air and electric are already made. Décor: High gloss silver

180806 3999,-



Technology package-in above furniture line built in

Built into furniture line as standard. Sink and stove with glass cover fit perfectly into the slate-colored countertop. Gas system prepared for 2x 5 kg gas bottle, compressor refrigerator Dometic CRP 40 (app. 39 l), 12 V/230 V system with Carbest switch-mode charger 20 A, 12 and 230 V socket, circuit breaker 13 A with FI, AGM battery 100 Ah, input socket and LED light are supplied for connection in the vehicle. 2x 12-l fresh water canister with tap and 18-l submersible pump. 27-liter waste water tank w/ mounted connections is supplied for installation in vehicle behind kitchen section.

191005E 3999,-



Truma gas heater VarioHeat eco

Built in furniture unit, incl. fireplace. Opening for chimney as well as the chimney still have to be attached to the vehicle.

720304E 2529,-



Table system with swivel table frame

multifunction table with integrated table frame in the bottom. It allows the table to be placed outside the vehicle and thus also serves as a camping table. Table top ca. 85x47 cm, material: laminate. Table decor: mandarin, table edge silver. Delivery includes stainless steel swivel table frame for mounting on the front panel of the bench.

10694S 679,-



Overhead locker

As prefabricated part above rear bench seat. Can be used as add. storage space. Only in combination w/ sleeping roof. High gloss silver

180816 469,-

Sideboard (see left side)

The sideboard is next to the bench and also serves as a bed widening incl. cushion.

50420M 549,-



Portable camping toilet Porta Potti 335

Suitable for TrioStyle furniture line. High quality plastic for maximum hygiene.

660102 149,-



▪ CONTENT ▪



REIMO TRIP 98-99

FURNITURE DECORS & UPHOLSTERY FABRICS 100-101

REIMO VAN-CONCEPT

CITROËN SPACETOURER PEUGEOT TRAVELLER TOYOTA PROACE VERSO OPEL ZAFIRA D LIFE FIAT ULYSSE

With the REIMO Trip extension your everyday vehicle becomes a true all-rounder with smart camping equipment.

Modern design language and high-quality materials create a feel-good ambience in the vehicle and the enormous variability offers a completely individual use for vacation and leisure.



REIMO TRIP - CITROËN SPACETOURER

Based on Citroën SpaceTourer M and identical, with original seating in rail system

The all-rounder with smart camping equipment

- Modular furniture line with elegant design
- Highest variability due to mounting in the original floor rails
- Thereby possibilities of use as 2-8-seater, camper and transporter
- Both furniture modules can be used independently
- Bed module using the original 2-person bench



With REIMO trip extension based on Citroën SpaceTourer/Peugeot Traveller or identical vehicles, you are particularly flexible on road thanks to modular extension.



Modern design language, noble and robust materials and the enormous variability in use make the extension an all-rounder and design highlight.

Maximum variability is achieved by anchoring in the original floor rails: This enables use as a camper as well as an everyday vehicle (2-8 seater) and van in equal measure. The modules can either be permanently installed or removed without tools. No modification to the base vehicle is required to install the modules.

Also suitable for following vehicles:

Peugeot Traveller from YOC. 2016, Toyota Proace Verso from YOC. 2016, Opel Zafira D Life (length 4.96 cm) from YOC. 2019
Fiat Ulysse from YOC. 2022

Technical specifications CitroënSpaceTourer

Sleeps on sleeping/seating bench:	1
Sleeping berths with optional sleeping roof:	3
Bed size sleeping roof:	198x120 cm
Light bed measure:	198 x 85/95 cm sleeping/ seating bench: 2 series bench
Seats with three-point seat belts:	4 to 8
Refrigerator: Compressor cooler	(40 l)
Stove:	1 flame gas cartridge
Fresh water:	16 Ltr. Canister
Waste water:	16 Ltr. Canister
Rear storage space under bed:	app. 140 x 65 x 43 cm
Storage space by bench:	60 x 65 x 43 cm

(data according to manufacturer)

Vehicle length (SWB)	app. 4956 mm
Vehicle width	app. 1920 mm
Vehicle height w/o. roof (SWB)	app. 1890 mm
Vehicle height w/ roof (SWB)	app. 2000 mm

Total permissible mass:	app. 2780 kg
Payload:	app. 1360 kg



Day position



Night position



For further equipment and options please contact Your specialist dealer. Fig. show partly special equipment, which are not incl. in scope of delivery.



Bed module

The module is screwed into the floor rails of the vehicle and can be removed. Comfortable single bed w/ sleeping surface app. 198 x 90 cm. The bed consists of a frame and foldable cushions that lay on the folded original bench. Cover black 100% polyester.

18373

770,-



Kitchen module as prefabricated part w/o. built-in technology

Kitchen module does not contain technology. This can be assembled and installed according to your own wishes. In the countertop of the kitchen module is already installed stainless steel sink. Prepared for 2 x 16 l water canisters. The kitchen module offers enough space for camping equipment and the optional 1-flame cartridge stove. The module is screwed into the original floor rails of the vehicle and can be removed in a few simple steps. W/ 2 roller shutter doors. Decor Pearl Black

18370

1999,-

Kitchen module as prefabricated part w/ built-in technology

In the kitchen module is already installed stainless steel sink and water system with removable faucet and hose for outdoor shower function. Submersible pump 18 l & 1x 16 l fresh & waste water canister each as well as cable connectors are part of equipment. Decor Pearl Black

18379

3499,-



Cooling box module as prefabricated part w/o. built-in technology

Cooling box module does not contain any technology, but has the cut-out in cover plate & is prepared for installation 40-l compressor cooling box, which is loaded from top.

The module is screwed into the original floor rails of the vehicle and is removable. In rear area there is storage compartment with door. Decor Pearl Black

18371

1799,-

Cooling box module as prefabricated part w/ built-in technology

Cooling box module is equipped w/ a complete technology package. Included are: 40 l compressor cooler, 12 V system with 60 Ah AGM battery, charge booster and cable plug-ins. Decor Pearl Black

18380

3999,-

Technical package 230 V as kit

Consisting of: Carbest switch-mode charger 20 A, CEE input socket, 13 A circuit breaker with RCD switch, charge booster, 1 x 230 V built-in socket and 12 V built-in socket. The 230 V kit is installed under the passenger seat and supplied as a kit.

18378

349,-



Table system w/ wall bracket With folding table base & bracket to hang on kitchen module. Table top HPL Pearl Metallic 15 mm Size: 76 x 46 cm. The table is stored behind the furniture line.

18372

299,-



Cartridge stove Camp Bistro DLX With safety lock system and piezo ignition. Power: 2200 W, Dims.: WxHxD37x12x28 cm, Weight: app. 1.9 kg

706474

64,99



FURNITURE DECORS - FLOOR TILES

Overview of furniture decors & floor panels for all finishing furniture

Furniture decors

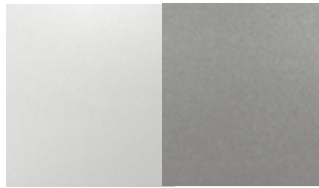

High-gloss white or silver
Poplar plywood with 0.6 mm HPL coating (High Pressure Laminate), both sides



Pearl black
Poplar plywood with 0.6 mm HPL coating (High Pressure Laminate), both sides



Anthracite metallic
Poplar plywood with 0.6 mm Laminate coating, both sides



High gloss olive
Poplar plywood with 0.6 mm HPL coating (High Pressure Laminate), on both sides



Walnut
Poplar plywood with 0.6 mm HPL coating (High Pressure Laminate), both sides



Apple
Poplar plywood with 0.6 mm HPL coating (High Pressure Laminate), both sides



Poplar plywood natural- T3
on both sides



Granitto -T3/T4/T5/T6
Poplar plywood with 0.6 mm HPL coating (High Pressure Laminate), both sides

Expansion Furniture decor	VW Caddy	VW T3	VW TrioLoft	VW Multi-Style	VW Sport Camper	VW Travel Style	VW Week-enderPlus	TrioStyle	VW/ Mercedes CityVan	Citroën Trip
High gloss white	● Camp			○				○ VW/Ford ● Mercedes	○	
High gloss silver								● Ford ● Renault		
Pearl black										●
Anthracite metallic							●		●	
High gloss olive/white	● Active		●							
Walnut						●				
Apple				●	●					
Poplar plywood nature		● Jolly								
Granitto		● Speedy ● Florida								
Floor panels										
Ship floor	● Camp	●	●	●	●	●	●	●	●	
Ticino		○	○	○	○	○	○	○	○	
Quad		○	○	○	○	○	○	○	○	
Granitto	● Active									

● Standard equipment / ○ Option with surcharge

Floor panels



Base plate ship's floor (series)
Waterglued chipboard with vinyl floor covering- coveringthickness: 10 mm



Base plate Tessin (surcharge)
Waterproof glued chipboard w/ robust vinyl floor covering , thickness: 10 mm



Quad base plate (surcharge)
Waterproof glued chipboard with vinyl floor covering, thickness: 10 mm

UPHOLSTERY FABRICS BENCHES

Upholstery fabric series all vehicles

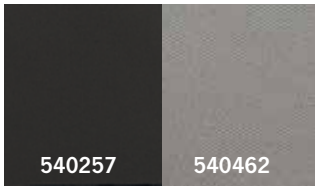

Series fabric
Classic dark gray/gray
 100% polyester, 3 mm foam laminated



Volkswagen Transporter upholstery fabrics at extra charge



Titanium black/bricks
 VW T6.1 original fabric, 100% polyester, 4 mm foam-laminated

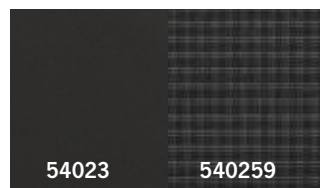

Titanium black/double grid
 VW T6.1 original fabric, 100% polyester, 3 mm foam-laminated

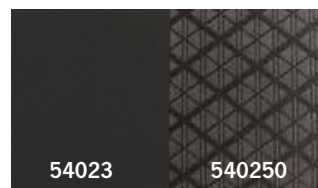

Titanium black/square
 VW T6.1 original fabric, 100% polyester, 3 mm foam-laminated

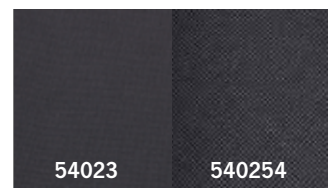

Titanium black/Austin 2-colored
 VW T6 original fabric, 100% polyester, 4 mm foam-laminated

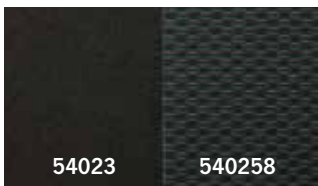

Titanium black/Simora 2-colored
 VW T6 original fabric, 100% polyester, 4.5 mm foam-backed

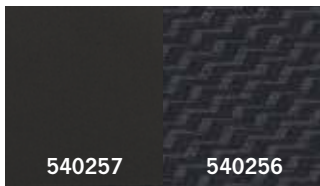

Dark gray/Tasamo 2-colored
 VW T5 original fabric, 100% polyester, 4.5 mm foam-backed



Classic gray/T5 Austin 2-colored
 VW T5 original fabric, 100% polyester, 4 mm foam-backed



Classic Grey/Inka 2-colored
 VW T5 original fabric, 100% polyester, 5 mm foam-backed

Upholstery Mercedes-Benz against surcharge

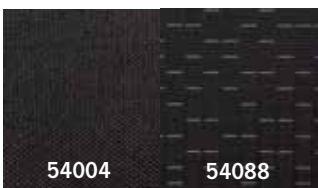

Uni black/caluma 2-colored
 Original Mercedes-Benz Vito fabric, flat fabric made of polyester, polyurethane, nylon.

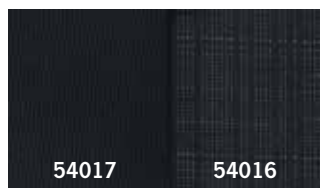

Black/Tunja 2-colored
 Original fabric Mercedes-Benz Vito, 100% polyester, flat weave.

Upholstery fabrics Ford against surcharge



Trend/Blue Stripe 2-colored
 Original fabric Ford, 100% polyester, 2 mm foam-backed

Upholstery fabrics Renault, Opel, Nissan, Fiat at extra cost

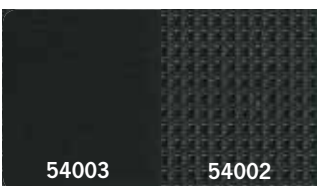

Black/Compo, 2-colored
 Renault original fabric, 100% polyester, 2 mm foam laminated and flat weave. Surcharge



Black/Black Patterned, 2-colored - from 2014
 Renault original fabric, 100% polyester, 2 mm foam laminated and flat weave. Surcharge

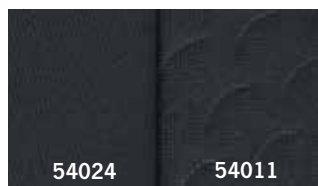

Black/Black scale, 2-colored
 Opel original fabric, 100% polyester, 2 mm foam-laminated and flat weaves. Surcharge



REIMO VAN-CONCEPT

REIMO MAXICAMPER

REIMO furniture modules that turn your Mercedes-Benz Sprinter into an individual camper.

With REIMO do-it-yourself kits you can turn your van into a maxicamper according to your individual wishes & requirements.

▪ CONTENT ▪

FURNITURE MODULES FOR MERCEDES-BENZ SPRINTER ..	104-105
BANK SYSTEMS FOR VOLKSWAGEN CRAFTER	106
BODY EXTENSIONS	107

FURNITURE MODULES FOR MAKERS

With the new REIMO self conversion kits for Mercedes-Benz Sprinter you build your individual camping bus according to your needs! With little effort, you can also use the modules variably.

Furniture decor: Olmo



Sleeping places/storage room

Sleeping roof

Do they need 2 more sleeping places, our maxivan sleeping roof is the right thing for you. Suitable for Sprinter, Crafter, Ducato as well as universal roof for almost all large panel vans. More info in REIMO camping bus conversion pro catalog on pg. 136.

Transverse bed in rear, furniture decor white
1,91x1,32 m (with side widening) consists of:

Storage cabinet left w/ compartment for 2 gas bottles 11 kg, space for combi C- gas heater/boiler, large compt. for up to 2 living room batteries & storage space, dims. app. 130x85x62 cm.

Storage cabinet right, intended for 105 l fresh water tank 61199, add. storage space. App. dims. 124x85x44 cm. Storage space for a camping table in front of rear door. Alternatively, a canister water system can be placed in the kitchen section.

Folding bed frame, ventilated

Between the wardrobes under the bed is provided a storage area 73 cm wide

1569001 1669,-

Bed cushion for rear bed, ready covered, 3 pieces, high quality foam 10 cm thick. The dimensions of the bed cushion are adapted to the rope body extension (Art. No. 15096).

1569002 529,-



Washroom/shower tray

Washroom for series high roof

2 side walls, back wall, ceiling and double-leaf door with magnetic lock

Dimensions WxHxD 91x190x79 cm

1569004 1249,-

Shower tray made of high quality GRP, extension of washroom to shower room, with wheel housing cover, intended for toilet cassette CT4110, raw size 110x85 cm, adaptable

16042 563,-



Overhead cabinets

Storage space above bench or in sleeping area. The overhead cabinets are particularly easy to install, the shelves sit in recesses provided in the roof rails on the right and left and are then bolted to the beams at the top. Door position upwards with high quality mechanics. Prepared for indirect LED lighting on the bottom edge

Roof hanging cabinet front left

WxHxD 100x38x25 cm

1569010 519,-

Overhead cabinet rear left

WxHxD 114x38x25 cm

1569011 559,-

Roof hanging cabinet rear right

WxHxD 114x38x25 cm

1569012 559,-



06
Base plate
 The basis for its further expansion is available as a ready-cut plate with a robust PVC coating or as a universal plate to cut to size yourself. Insulation of 15 mm with the Reimo X-Trem isolator is provided.

09
Cladding/insulation
 After the installation of windows and insulation of the wall and roof is a matter of cladding the walls and doors. Depending on your preference, you can buy from Reimo 3 mm cladding panels, prefabricated wooden cladding kits or thermoformed cladding parts. For the side and roof cladding we recommend our 3 mm cladding panels in combination with X-Trem insulator for insulation. Open sheet metal surfaces can be well covered with X-Trem Stretch Carpet felt.

Base plate contour milled
 10 mm waterproof glued chipboard, PVC covering decor Ticino,
 Dimensions app. 3,32x1,78m
15905 419,-

Cladding panel Galloway
 3 mm plywood coated, 1,22x2,50 m
510071 74,95

Stretch Carpet Dark gray 10 sqm,
500840 139,-

You will find further products in our accessories program.

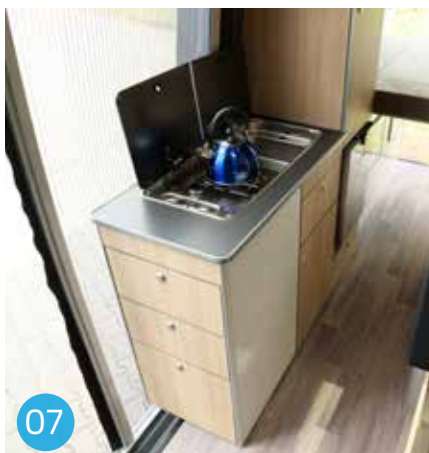

Bench

Depending on their tastes and needs, they have great options with the bench, which combines well with the table system.

Whether with an optional three-point harness frame for 2 more registered seats or just a large, comfortable seat box. Rear furniture is required for mounting the backrest

Seatbox as a cozy seating area, with ample storage space. WxHxD 74x36x57 cm (not approved for passenger transport).

1569006 249,-

Foam set for seat box
 wedge cut for better seating comfort
1569007 169,-

Upholstery set seat and backrest Original fabric Sprinter uni black,
1569008 319,-

Alternatively, you can also use a universal belt buck from our program, clarify the registration in advance with your TÜV



07
Kitchen module
 Kitchen block w/ ample storage space. With space for sink and stove, drawer for cutlery and space for pots and dishes. 4 drawers, 1 cabinet compt.
 Decor Olmo, worktop Pearl black, dimensions app. WxHxD 93x91x46 cm
1569005 1249,-



10
Windows
 The agony of choice. If I want good insulation, I choose frame windows with double glazing. If the vehicle should not be immediately recognizable as a motorhome, I choose rigid or sliding all-glass windows. Reimo offers more than 10 different types of windows. For more details look in the catalog or on our homepage.



05
Table system
 Suspension table with solid single table base and 2-piece swing-out table top.
1569009 349,-



08
Closet
 w/ compt. for compressor refrigerator 50 l (713570) and cabinet area, storage drawer as access aid at the bottom
 Dims. app. WxHxD 42x190x50 cm
1569003 799,-



11
Car body extension
 for 6 m Mercedes-Benz Sprinter, only for driver's side, extends interior by app. 80 mm, material: GRP, surface gelcoat white, paintable, mounting with Sikaflex
15096 499,-

RIDE COMFORT & EQUIPMENT

For large panel vans



Single seat A400

The approved seat with three-point seat belt for Mercedes-Benz Sprinter, Volkswagen Crafter and Fiat Ducato.

In conjunction with the aluminum slide rail, the seat can be moved or removed. Choose from 2 plinth heights to find their comfort position. You will need one right and one left socket. Maximum 3 seats can be mounted in one row.

Single seat A400 with 2 armrests

Belt connection left	59372	1199,-
Belt connection right	59371	1199,-

Seat base height 23 cm (seat height 41 cm)

left	59366	137,90
right	59365	137,90

Seat base height 28 cm (seat height 46 cm)

left	59368	137,90
right	59367	137,90

Aluminum slide rail

double-row for attaching one seat or several seats in a row. Approx. 1 meter seat rail required per seat.

Length 2,40 m	59379	376,-
---------------	--------------	--------------

Special glue (600 ml)

for gluing the bottom rail	593795	28,95
----------------------------	---------------	--------------

BODY EXTENSIONS

For large panel vans

For Mercedes-Benz Sprinter from YOC. 2006 (NCV3, VS 30) length 593 mm and Volkswagen Crafter 1 and 2 / MAN TGE, length 593 cm and 599 cm respectively

Fitting a body widener to Sprinter & Crafter extends bed width in rear of vehicle by app. 110 mm on the driver's side (left) and by app. 60 mm on the passenger side (right).

The widened space makes it easy to install a transverse bed in the rear of your maxi camper. Increase sleeping comfort by equipping both sides of the vehicle with a body extension. The aerodynamic GRP shapes adapt very well to the vehicle contours and increase the vehicle width by only a few centimeters.

Assembly: The extensions are firmly bonded to the body and stably connected to the vehicle wall by means of additional rivets. Available for driver side (MB Sprinter, VW Crafter, MAN) & passenger side (VW Crafter, MAN).



Fig. shows widening left, MAN

For Volkswagen Crafter 2 / MAN TGE

For VW Volkswagen 2 / MAN TGE from YOC. 2016, vehicle length: 593 cm or 599 cm. Material: GRP, surface: gelcoat black, paintable.

Position: left, extends the interior space by app. 110 mm.

15095 529,- Position: right behind the sliding door. Extends the interior space by app. 60 mm.

150951 529,-

Optional accessories:

Sliding door spacer kit for Volkswagen Crafter 2 / MAN TGE

The sliding door clearance kit is required if a body extension is fitted on the right. The kit extends the distance between the open sliding door and the vehicle body. This means that the sliding door can be opened completely even when the body extension is fitted.

28500 139,-



Fig. shows widening Volkswagen Crafter 2, right

For Volkswagen Crafter 1 / Mercedes-Benz Sprinter 2

For Volkswagen Crafter 1 / Mercedes-Benz Sprinter 2 from YOC. 2006 (NCV3, VS 30), vehicle length: 593 cm. Material: GRP, Surface: Gelcoat. Color black (VW Crafter 1), color white (MB Sprinter), paintable. **Position: left**, extends the interior by app. 80 mm.

15096 499,-



Fig. shows widening Mercedes-Benz Sprinter 2, left

REIMO VAN-CONCEPT

VEHICLE- THOUGHTS

The extensive range of REIMO roofs offers a unique variety of variants for different base vehicles and use.

Whether sleeping roof, high roof or elevating roof, here you will find the solution for your needs.



▪ CONTENT ▪

ROOF VARIANTS/ADVANTAGES REIMO SLEEPING ROOFS.....	110-113
EASYFIT SLEEPING ROOF VOLKSWAGEN T6.1/T6/T5	114-121
SLEEPING/SUPER FLAT/HIGH AND LIFT ROOFS FOR VOLKSWAGEN T6.1/T6/T5	122-124
SLEEPING / HIGH AND LIFT ROOFS FOR VOLKSWAGEN T4	125-126
SLEEPING / HIGH AND LIFT ROOFS FOR VOLKSWAGEN T3	127
VOLKSWAGEN CADDY MAXI SLEEPING ROOF	129
SLEEPING ROOFS FOR FORD/FIAT SCUDO	130
SLEEPING ROOFS FOR CITROËN BERLINGO / JUMPY	131
SLEEPING AND HIGH ROOFS FOR MERCEDES VITO/SPRINTER	132-133
SLEEPING AND LIFTING ROOFS FOR RENAULT TRAFIC	134-135
SLEEPING ROOFS FOR MAXIVANS	136-137
UNIVERSAL LIFTING ROOFS.....	138-139
REIMO ROOF VARIANTS	140
ACCESSORIES SLEEPING ROOFS	141-142
SOLAR SYSTEMS SLEEPINGROOFS/ACCESSORIES FOR HIGH ROOFS	. 143
SPARE PARTS FOR SLEEPING & LIFTING ROOFS	144-145



THE RIGHT ROOF FOR YOUR CAR

Sleeping roof, elevating roof and high roof features

Solar technology
for roofs on page
139

Why a sleeping roof?

The Reimo sleeping roof offers the possibility to set up an additional bed with a lying surface of approx. 120 x 200 cm in a compact vehicle.

When set up at an angle, depending on type of vehicle, interior height achieved is app. 180 - 240 cm.

Depending on the model, the roof is equipped with up to 3 windows with mosquito nets, which, depending on model, can be opened & provide good ventilation.

On most REIMO sleeping roofs you can transport loads up to approx. 30 kg (surfboard or other). Optionally, the sleeping roofs can be equipped with solar panels.



Advantages of a high roof

The REIMO high roof has a solid GRP plastic shell and provides additional storage and living space. It is the solution for the camper who wants to be on the road in almost every season. The fiberglass-reinforced plastic shell is perfect for this, even in bad weather. The aerodynamic shape of the Reimo high roof keeps fuel consumption in check.

Depending on the vehicle type, the roof cutout can be of different sizes (between the crossbars or from windshield to rear). For some roofs Reimo offers a GRP inner shell, ie: You have a clean, smooth and easy to clean interior surface in a simple, convenient way.

Reimo offers a velour interior trim for the Ergoline series. Here you will be supplied with velour fabric covered, pre-glued 20 mm insulation panels.



The classic interior cladding with cladding panels: Here, a lath framework must be glued to the shell with Sikaflex adhesive, then insulated and the wooden cladding attached to it.

In a Reimo high roof can be mounted roof hoods or windows for additional ventilation.

For the transport of surfboards or similar, we recommend our carrier systems (see pages 142-143).

Lifting roof: The inexpensive solution

REIMO elevating roof: The inexpensive variant when standing height is only required in kitchen/dressing area.

The interior under the elevating roof is raised by app. 45 cm, allowing standing height on an area of app. 1 m².

Depending on type of vehicle, the roof adds about 6-12 cm. Good ventilation is provided by 3 windows w/ mosquito net insert that can be closed w/ tent fabric.

The elevating roof must be set up in parallel. Installation is usually carried out in area of sliding door.



NOTE: To ensure that you can enjoy your correctly installed sleeping roof for a long time, we only sell sleeping roofs & raised roofs to specialist dealers trained by us.

TENT BELLOWS VARIANTS

What are the options?

Climagic tent bellows Larger windows, top breathability



This new tent bellows for Volkswagen Transporter 6.1/6/5 short wheelbase is made of a new synthetic material specially developed for this application. This features improved weather resistance, breathability and durability, as well as easier maintenance.

The new tent bellows design with 3 large mosquito windows ensures a particularly airy room experience, best ventilation and plenty of light inside. (window can be closed by means of inner cover).

All 3 mosquito nets are zip-on.



OpenSky Tent Bellows More fresh air and view

For Volkswagen Transporter 6.1/6/5 Easy Fit sleeper roof, high front, short and long wheelbase,

Enjoy the view and plenty of fresh air with the OpenSky Tent Bellows. Easy to open with the sewn-in zipper and attach to the roof with loops.

NOTE: For your own safety and that of your children, do not sleep with the tent bellows open so no one can fall out.

For more information, visit www.reimo.com



Sleeping roofs with this symbol are suitable for OpenSky

Conventional tent bellows Living comfort with light and air

For Volkswagen Transporter 6.1/6/5, front and rear high, short and long wheelbase.

Also the normal tent bellows offer plenty of light and air through 2 large side windows and a foil window in the front. The side windows are equipped with mosquito nets that can be opened and provide protection from annoying insects.

An easy-to-open blackout is provided by all 3 windows. A forced ventilation system w/ mosquito netting is located underneath roof shell in front area and provides additional fresh air in the vehicle.



ADVANTAGES OF REIMO SLEEPING ROOFS

10 decisive advantages why REIMO roof is a good decision



Low vehicle height

Your vehicle fits into most standard garages (usual: 2,00 - 2,04 m, please measure)

Simple operation

Easy, almost automatic erection of the roof, high reliability due to gas struts.

Open Sky Tent Bellows (opt.)

Tent bellows that can be opened w/ a zipper. So you can enjoy the view. Please observe the safety instructions at www.reimo.com

Quick-Lock locking system (optional)

Safe and reliable closing without straps and Bowden cables.

Living comfort with light & air

Velour roof lining for best insulation, feel and moisture balance. 2 large mosquito net windows to open. Windows darkenable, 1 forced ventilation for 1 foil window. (Equipment varies acc. to vehicle & roof type)

Foot clearance

A large, high scissor achieves ample space in the footwell of the bed. New stainless steel comfort shear offers up to 45 cm of foot clearance.

An extra double bed in the roof

In the additional roof bed creates a sleeping area of about 190-200 cm in length and a width of 120-130 cm.

Top aerodynamics

Aerodynamic shape for low wind noise and fuel economy.

Insulation & stability through sandwich construction

Roof shell in sandwich construction w/ integrated insulation & reinforcement for roof load up to max. 30 kg.



Insulation & stability through sandwich construction

- ① Gelcoat
- ② Fiberglass shell
- ③ laminated inner frame
- ④ Reinforcement material
- ⑤ Glass fiber top layer
- ⑥ Isovelours with lamination

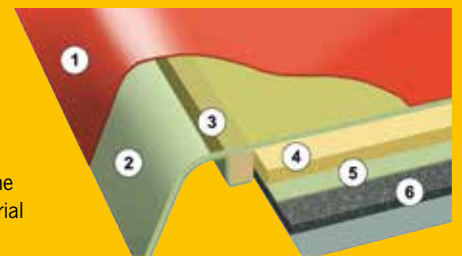

Our roofs are Made in Germany.





Open Sky Tent Bellows

Sleep like at home - the new REIMO luxury beds for sleeping roofs AT REIMO LUXURY BECOMES THE NEW STANDARD



Aperture of the entrance opening



Luxury beds w/ spring system for perfect sleeping comfort on the road

Luxury beds have a large number of plastic spring elements and offer you the highest level of sleeping comfort, just like at home. A 40 mm thick mattress provides the best lying comfort, a fabric panel for the roof access provides a homely look for easy access to the roof bed. Gas springs assist in raising and lowering the bed. For EasyFit sleeper roof for Volkswagen Transporter 6.1/6/5, Mercedes-Benz Vito and Citroën SpaceTourer.

- As a new standard, new luxury beds are available for the REIMO EasyFit sleeping roofs for Volkswagen, Mercedes-Benz Vito and Citroën SpaceTourer
- A plastic spring system provides maximum comfort and ensures a pleasant sleep
- Comfortable, 40 mm foam mattress



Color confess

with the colored sleeping roof-Tent bellows from REIMO



Bring color to your camping vacation with a colored sleeping roof tent bellows. Individualize so your camper and give their vehicle an independent look and a noble appearance.

The colored tent bellows are available for sleeping roof Easy Fit w/ standard tent bellows, Open Sky or Climagic tent bellows, for the vehicles VW T6.1 / T6 / T5 short wheelbase front high.

You will find our configurator on page 117.

Choose from 4 colors your tent bellows.

LIGHT GRAY (STANDARD)

RED

BLUE

ANTHRAZITE

REIMO

EasyFit sleeping roof

Sleep like on clouds



MADE IN
GERMANY



Decisive advantages of the EasyFit sleeping roof

- The REIMO EasyFit sleeping roof is extremely flat & aerodynamic
- The GRP roof shell is already provided with integrated insulation during manufacture
- Textile interior lining with foam lamination, - insulating, noise absorbing and moisture compensating
- The Easy-Up system facilitates the closing of the roof and protects the tent bellows
- The separate front spoiler ensures low wind noise
- Installation possible in app. 6 hrs. (without cladding roof cutout)
- Simple and reliable operation due to gas struts
- Headroom with open roof incl. bed approx. 205 cm front, 150 cm rear (start of roof cutout/start of C-pillar)
- Secure roof closure with 2 straps or optional Quick-Lock closure system
- Reinforcement frames integrated and available in two versions:
 - Standard for vehicles with hardboard interior trim
 - Optional for vehicles with molded headliner/climate headliner
- Various tent bellows options
- Optional roof bed -sleeping area approx. 195 cm x 120 cm
- Foot clearance in bed under scissors about 45 cm

The following EasyFit variants are available:

- Configured to your requirements for VW T6.1/T6/T5 short wheelbase, front high, page 119
- VW T6.1/T6/T5 short wheelbase, rear high, page 118
- VW T6.1/T6/T5 long wheelbase, front/rear high, page 118
- Ultraflat for VW T6.1/T6/T5 short wheelbase, front high, page 119
- Citroën Jumpy/SpaceTourer & similar, page 131
- Mercedes-Benz Vito length 514 cm, front high, page 132
- Renault Trafic, Fiat Talento, Opel Vivaro short wheelbase, front high, page 134

YOUR EASYFIT DESIRED SLEEPING ROOF

For Volkswagen T6.1/T6/T5 - Short wheelbase - Front high



Tent bellows Climagic in gray



Tent bellows OpenSky in gray

Configure your dream sleeping roof:

Our EasyFit sleeping roof is available in numerous variants and is manufactured individually according to your wishes.

You get the proven REIMO quality with every roof. Set up with the patented Slider sleeper roof shears in stainless steel for more leg room and comfort set up.

The composition is done step by step with a configurator.



Based on the EasyFit Standard sleeping roof: Shell Standard, Frame Standard, Strap Closure, Tent Bellows Standard Gray - Item no. 21150XXX- 4269,- your selection of the individual components results in the final price.

HOW TO CONFIGURE YOUR INDIVIDUAL EASYFIT SLEEPING ROOF

For Volkswagen T6.1 / T6 / T5 with short wheelbase
Item number 21150XXX, base price 4269,-
(the base price includes prices of standard equipment)

1. Select the shell type:

1.1 EasyFit Standard shell: GRP shell with integrated insulation and reinforcement frame. **Series 21150XXX 4269,-**

1.2 EasyFit V-Tec shell: The EasyFit V-Tec construction is a GRP sandwich construction of inner and outer shell, light and stable with integrated reinforcements and insulation. The elegant, smooth surface is easy to clean inside and out. **Surcharge 400,-**

2. Select the type of EasyFit frame, suitable for:

2.1 Transporter/station wagon vehicles **Series 0,-**

2.2 Vehicles w/ molded headliner/ climate headliner **Surcharge 70,-**

3. Select the shutter type:

3.1 strap lock: Safe and reliable locking with 2 tension straps **Series 0,-**

3.2 QuickLock closure: Quick and easy unlocking via the handles, similar to a car door lock **Surcharge 390,-**

3.3 Electrical installation and locking: Echain drive with a stainless steel chain opens and closes the roof at the touch of a button **Surcharge 1490,-**

4. Choose the tent bellows type and color

4.1 Standard tent bellows: With 2 side windows and mosquito nets (zip-on) and foil front window. All windows with blackout. Forced ventilation w/ mosquito net at top of front.

4.1.1. light gray: **Series 0,-**

4.1.2. anthracite: **Surcharge 99,-**

4.1.3. blue: **Surcharge 99,-**

4.1.4. red: **Surcharge 99,-**

4.2 Climagic* tent bellows: For sun campers. With 3 enlarged windows, each equipped with mosquito netting and blackout. All mosquito nets can be opened.

4.2.1. light gray: **Surcharge 249,-**

4.2.2. anthracite: **Surcharge 349,-**

4.2.3. blue: **Surcharge 349,-**

4.2.4. red: **Surcharge 349,-**

4.3 Tent bellows OpenSky*: Features like standard bellows. An additional circumferential zipper opens the complete front area far into the side, you are virtually in the open air. Attention, fall hazard: not suitable for small children.

4.3.1. light gray: **Surcharge 199,-**

4.3.2. anthracite: **Surcharge 299,-**

4.3.3. blue: **Surcharge 299,-**

4.3.4. red: **Surcharge 299,-**

*In extreme weather conditions it may be necessary to close the roof or use additional climate protection.

5. Special equipment solar panel

5.1st version standard: without solar module **Series 0,-**

5.2. Version with bonded solar module 120-130W:

A flexible solar module is glued to the sleeping roof and the cable is laid up to the Easyfit frame. A suitable charge controller is included.

Solar panel installed, **Surcharge 999,-**

6. Active beam profile

6.1st version Standard: w/o. active support profile **Series 0,-**

6.2 Active support profiles installed: 4 aluminum profiles, each 400 mm long, are screwed and glued to the sleeping roof shell. This allows the installation of roof racks with a roof load of 30 kg. **Surcharge 369,-**

ACCESSORIES (not included in the configuration):

Luxury sleeping roof bed (description page 119) 211530 729,-

Tent bellows insulation (description page 141) 373981 459,-

Climate protection hood (description page 141) 37391 499,-

Roof cladding for the standard EasyFit frame (description page 118) 10583-2 189,-

ALL INFO AND CONFIGURATOR AT WWW.REIMO.COM

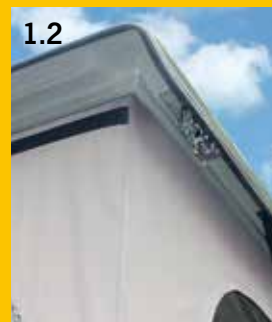

VOLKSWAGEN T6.1/T6/T5 - SLEEPING ROOF EASYFIT

Short and long wheelbase, set up front or rear high



- Standing height (roof open) app. 205-150 cm
- 3-section sleeping roof, integrated GRP reinforcement frame, pre-assembled
- a total weight short wheelbase app. 60 kg, long wheelbase app. 70 kg
- Color white

Low vehicle height, high everyday utility. Caution: The vehicle heights vary depending on the model. Please remeasure your vehicle.

Sleeping roof EasyFit for Volkswagen T6.1/T6/T5 long wheelbase, installation front high

Part number 21162XXX, base price 5190,-

1. Select the shell type:

1.1 tray EasyFit Standard front high	Series	5190,-
1.2 Tray for electric roof front high	Surcharge	400,-

2. Select the type of EasyFit frame, suitable for:

2.1 Transporter/station wagon vehicles	Series	0,-
2.2 Vehicles w/ molded headliner/climate headliner	Surcharge	70,-

3. Select the shutter type:

3.1 strap closure:	Series	0,-
3.2 QuickLock fastener	Surcharge	390,-
3.3 Electrical installation and interlocking	Surcharge	1490,-

4. Choose type of tent bellows

4.1 Tent bellows standard:	Series	0,-
4.2 Tent bellows OpenSky:	Surcharge	199,-

5. Special equipment solar panel

5.1 version standard: without solar module	Series	0,-
5.2 version with bonded solar panel 120-130W	Surcharge	999,-

6. Active beam profile

6.1 version standard: w/o. active support profile	Series	0,-
6.2 active beam profiles installed	Surcharge	369,-

Sleeping roof bed LUXURY, incl. disc spring system, front high

Disc spring system for increased sleeping comf., ventilated from below. Sleeping surface app. 132 x 197 cm, comfort cushion app. 108 x 200x4 cm.

A screen covers the ascent opening during travel.

LWB, front high	211670	855,-
-----------------	--------	-------



Sleeping roof EasyFit for Volkswagen T6.1/T6/T5

Installation rear high Long wheelbase:

With strap closure	2116203	5490,-
W/ belt buckle & air-conditioned headliner	2116203C	5590,-

Matching sleeping roof beds for EasyFit sleeping roof rear high

Sleeping roof bed laminate gray. Pre-assembled, gas spring assisted. Sleeping surface approx. 126 x 209 cm. Cushion dimensions app 107 x 200x4 cm, cover 100% polyester, removable & cleanable.

LWB, rear high	21158	799,-
----------------	-------	-------

Short wheelbase:

With strap closure	2115003	4990,-
--------------------	---------	--------

Matching sleeping roof bed for EasyFit sleeping roof rear high

Sleeping roof bed laminate gray. Pre-assembled, gas spring assisted. Sleeping surface app. 125 x 191 cm. Cushion dims. app. 107 x 184 x 4 cm, 3 cm thick. Cover 100% polyester, removable and cleanable.

SWB, rear high	21156	799,-
----------------	-------	-------

EasyFit roof lining for EasyFit sleeping roofs front and rear high

(not for climate headliner) For climate headlining, the original roof trim is reused) For cladding the roof cutout/roof lining in the living area, 3 mm hardboard, raw (uncoated).

Long wheelbase	105843	189,-
----------------	--------	-------



Freight flat rate sleeping roofs: For delivery within Germany or collection from specialist dealer

225	104,-
-----	-------

VOLKSWAGEN T6.1/T6/T5 - EASYFIT ULTRAFLAT SLEEPING ROOF

Short wheelbase



ULTRAFLAT EASYFIT sleeping roof

Vehicle height under 2 m

- Um 30 mm flatter design compared to the common EasyFit design
- The overall height of most T6.1/T6/T5 base vehicles of 2 m is not exceeded
- Easy-Up mechanism facilitates opening and closing of the roof
- The higher comfort scissors have enabled a foot clearance of approx. 45 cm (compared to the EasyFit design)
- Rear seat height for persons up to 170 cm tall (in combination with luxury bed 211530)

EasyFit Ultraflat sleeping roofs for VW T6.1/T6/T5 short wheelbase, set up front high, pre-assembled



Standing height (roof open) app. 205-150 cm. 3-piece sleeping roof, integrated GRP reinforcement frame, total weight approx. 60 kg. Color white.
With strap closure **2806401** **4690,-**

Optionally available:
Open Sky Tent Bellows, extra charge **2929981** **199,-**

Matching sleeping roof bed for EasyFit Ultraflat sleeping roof

Luxury sleeping roof bed with spring system

A variety of plastic spring elements provide increased sleeping comfort High lying comfort due to 40 mm thick mattress. No suitable orifice for entry opening.
 Sleeping surface app. 198 x 123 cm. Cushion dimensions app. 185 x 108 x 4 cm.
SWB, front high **211530** **729,-**

Freight flat rate sleeping roof: For delivery within Germany or collection from specialist dealer **225** **104,-**



YOUR EASYFIT V-TECH II DESIRED SLEEPING ROOF

For Volkswagen T6.1/T6/T5 – Short wheelbase – Front high



Configure your dream sleeping roof:

Our EasyFit V-Tech II sleeping roof is available in numerous variants and is manufactured individually according to your wishes.

You get the proven REIMO quality with every roof. Set up with the patented Slider sleeper roof shears in stainless steel for more leg room and comfort set up.

The composition is done step by step with a configurator.

Based on the EasyFit V-Tech II standard sleeping roof:

**EasyFit V-Tech II shell, Standard frame,
Strap closure, tent bellows standard gray -
Article no. 21190XXX- 4399,-**

your selection of the individual components results in the final price.

HOW TO CONFIGURE YOUR INDIVIDUAL EASYFIT V-TECH II SLEEPING ROOF

For Volkswagen T6.1 / T6 / T5 with short wheelbase
Item number 21190XXX, base price 4399,-
(the base price includes prices of standard equipment)

EasyFit V-Tec II shell: The EasyFit V-Tec II body is a GRP sandwich construction, lightweight and strong with integrated reinforcements and insulation. The elegant, smooth surface is easy to clean inside and out.

1. Select the type of EasyFit frame, suitable for:

- | | | |
|---|------------------|-------------|
| 1.1 Transporter/station wagon vehicles | Series | 0,- |
| 1.2 Vehicles with molded headliner/climate headliner | Surcharge | 70,- |

2. Select the shutter type:

- | | | |
|---|------------------|---------------|
| 2.1 strap lock: Safe and reliable locking with 2 tension straps | Series | 0,- |
| 2.2 QuickLock closure: Quick and easy unlocking via the handles, similar to a car door lock | Surcharge | 390,- |
| 2.3 Electrical installation and locking:
Echain drive with a stainless steel chain opens and closes the roof at the touch of a button | Surcharge | 1490,- |

3. Choose the type of tent bellows

- 3.1 Standard tent bellows:** With 2 side windows and mosquito nets (zip-on) and foil front window. All windows with blackout. Forced ventilation w/ mosquito net at top of front.
- 3.2 Climagic* tent bellows:** For sun campers. With 3 enlarged windows, each equipped with mosquito netting and blackout. All mosquito nets can be opened.
- 3.3 Tent bellows OpenSky*:** Features like standard bellows. An additional circumferential zipper opens the complete front area far into the side, you are virtually in the open air. Attention, fall hazard: not suitable for small children.

*In extreme weather conditions it may be necessary to close the roof or use additional climate protection.

4. Special equipment solar panel

- | | | |
|--|------------------|--------------|
| 4.1. version standard: without solar module | Series | 0,- |
| 4.2. Version with bonded solar module 120-130W:
A flexible solar module is bonded to the sleeping roof and the cable is laid into the Easyfit frame. A suitable charge controller is included.
Solar panel installed, | Surcharge | 999,- |

5. Active beam profile

- | | | |
|---|------------------|--------------|
| 5.1st version Standard: without active support profile | Series | 0,- |
| 5.2. Active support profiles installed: 4 aluminum profiles, each 400 mm long, are screwed and glued to the sleeping roof shell. This allows the installation of roof racks with a roof load of 30 kg. | Surcharge | 369,- |

ACCESSORIES (not included in the configuration):

- | | | |
|--|----------------|--------------|
| Luxury sleeping roof bed (description page 119) | 211530 | 729,- |
| Roof cladding for the standard EasyFit frame (description page 118) | 10583-2 | 189,- |

ALL INFO AND CONFIGURATOR AT WWW.REIMO.COM

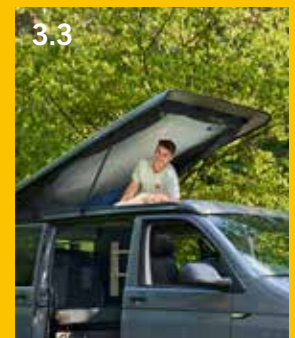



SLEEPING ROOF SUPER FLAT - VOLKSWAGEN T6.1/T6/T5

Short and long wheelbase

Super sleep in REIMO super flat roof



Features Sleeping roof super flat Short and long wheelbase, fronte high and rear high

- With parts certificate
- Vehicle elevation approx. 7 cm
- Tent bellows breathable
- Good ventilation thanks to 3 windows that can be closed from inside w/ tent fabric (2 side windows w/ removable mosquito net insert, front window foil)
- Headroom (roof open) approx. 195 - 245 cm
- Color white
- When assembling the roof scissors and the tent bellows are attached to the vehicle
- Installation frame required for mounting, is mounted on the roof cutout of the vehicle roof



Extra sturdy scissor mechanism



2 side mosquito net windows



The sleeper roof super flat short wheelbase is supplied with a rubber spoiler as standard.



Sleeping roof super flat long wheelbase, front and rear high, comes standard with an aerodynamic spoiler.



Sleeping roof super flat for VW T6.1/T6/T5 short wheelbase, installation front high

With strap closure **210960 2990,-**

Sleeping roof bed Volkswagen Transporter SWB from 2003

Gray, wooden panel 2-piece incl. foam and cover gray, 100% polyester. The divided sleeping roof bed guarantees high freedom of movement in living position. Sleeping surface app. 200 x 120 cm. Cushion dims. app 182 x 110 x 3 cm thick.

21097 599,-

Folding bed for sleeping roof Volkswagen Transporter SWB Multivan w/ Klimatronic. Suitable only for mounting frame 210931.

Wooden top 3-piece incl. foam and cover gray, 100% polyester. Sleeping surface about 210x120 cm. Mattress about 4 cm thick. Incl. Material to convert a Multivan with Klimatronic and GPS.

Graffiti laminate **21099 719,-**

Installation frame for Multivan w/ Klimatronic **210931 489,-**



Sleeping roof super flat for VW T6.1/T6/T5 long wheelbase, Set up front high, with spoiler

With strap closure **21085 3690,-**

Sleeping roof bed Transporter long wheelbase

Sleeping surface app. 210x120 cm. Cushion dims. app. 182x110x3 cm thick. Color gray. **21082 619,-**



Sleeping roof super flat for VW T6.1/T6/T5 long wheelbase, Set up rear high, with spoiler

With strap closure **21075 3590,-**

Sleeping roof bed Transporter long wheelbase

Sleeping surface app. 210x120 cm. Cushion dims. about 200x110x4 cm thick. Color gray. **21076 639,-**

Required installation frame for sleeping roof long wheelbase, front and back high

Roof cutout incl. driver's cab

Left-hand drive **21081 608,83**

righthanddrive **21081R 599,-**



Sleeping roof super flat for VW T6.1/T6/T5 short wheelbase, Line up rear high

With strap closure **21069 3390,-**

Sleeping roof bed Volkswagen Transporter SWB, from 2003

Wooden plate gray incl. foam and cover gray, 100% polyester. Sleeping surface app. 200 x 120 cm. Cushion dims. about 200 x 110 x 3 cm thick. **21070 639,-**

Required installation frame for sleeping roof short wheelbase from 2003, front and rear high

Roof cutout incl. driver's cab.

Left-hand drive **21093 469,-**

righthanddrive **21093R 469,-**



Freight flat rate sleeping roof:

For delivery within Germany or collection from specialist dealer **225 104,-**

*only valid with our offered mounting frames. Standard color of the roofs white, illustrations partly show additional equipment. For additional charge, we are happy to paint your vehicle roof in your preferred colour.



LIFTING ROOFS - VOLKSWAGEN Transporter 6.1/6/5

Long and short wheelbase

LIFTING ROOF EASYFIT ULTRAFLAT

For Volkswagen Transporter T6

- The new elevating roof with EasyFit subframe
- Vehicle increase by only 5 cm
- Less noise at higher speeds due to integrated front spoiler

The EasyFit subframe allows perfect adaptation to the roof structure of the vehicle. The roof provides standing height in an area of 98 x 92 cm. 3 closable tent fabric windows with mosquito net insert.

Tent bellows gray.

Suitable for VW T6 between B-pillar and C-pillar. Roof elevation app. 5 cm, extended headroom 5 cm with the roof closed and 50 cm with the roof open.

Roof cutout W 100 x L 95 cm

2118501 2790,-



LIFTING ROOF SUPERFLAT- VOLKSWAGEN T6.1/T6/T5

Long and short wheelbase

For Volkswagen Transporter T6/T5, short or long wheelbase, from YOC.

2003. Parallel and gas spring assisted setting up. Interior elevation app. 45 cm.

3 closable tent fabric windows with mosquito net insert.

Tent bellows gray

Roof cutout app. L106 x W101 cm.

Vehicle elevation app. 7 cm.

Roof size app. L170 x B130 x H11 cm.

Weight app. 37 kg.

Roof shell color white (R9002).

With parts certificate*

21185 2190,-

*only valid with our offered mounting frames.

Standard color of the roofs white, illustrations partly show additional equipment. For additional charge, we also paint your vehicle roof in color of your choice.

Flat-rate freight charge for lifting roof:

For shipment within GER or collection from specialist dealer

227 53,40



VOLKSWAGEN T6.1/T6/T5 - HIGH ROOF SPORTLINE

Short wheelbase, from YOC. 2003



Sporty and aerodynamic. With parts certificate*, standing height app. 185 cm. Van character. Roof dims. app. L293 x W153 x H56 cm. Vehicle elevation app. 45 cm. Bed not useful. Color white
21090 1469,-
Interior trim 21060 1099,-

Mounting frame Volkswagen Transporter from 2003

TÜV approved. Available with or without cab cutout:

With cab cutout

Advantage: headroom in the driver's cab, easy "walking to the rear".

Roof cutout approx. 280 x 110 cm. Not possible w/ Sunroof in driver's cab.



 Left-hand drive		 righthanddrive	
21093	469,-	21093R	469,-

Without cab cutout

Advantage: storage space above driver's cab. Storage

compartment possible

(not for sleeping roof) Roof cutout approx. 240 x 110 cm.

 Left-hand drive		 righthanddrive	
21094	399,-	21094R	399,-



VOLKSWAGEN T6.1/T6/T5- HIGH ROOF ERGOLINE

Short or long wheelbase, from YOC. 2003



High roof Ergoline for short wheelbase, w/ parts certificate*.

Classic, smooth roof shape. Vehicle elevation app. 73 cm.

Headroom app. 208 cm. Color white **21048 1699,-**

Interior paneling

20 mm insulation material with gray isovelours **21049 1199,-**

Mounting frame Volkswagen Transporter SWB (Fig. p. 122)

With cab cutout. TÜV incl., bed support integrated, with Cab cutout (roof

cutout app. 280 x 110 cm). Advantage: headroom in the driver's cab, easy

"walking to the rear". Not with Sunroof in the cab.

 Left-hand drive		 righthanddrive	
21093	469,-	21093R	469,-

Without cab cutout (Aperture: approx. 203x113 cm).

Advantage: storage space above driver's cab. Storage compt. possible

(not for sleeping roof)

Especially for vehicles with Klimatronic 210931 489,-

High roof bed Volkswagen Transporter SWB

Wooden plate gray incl. foam mattress about 6 cm thick and cover gray,
 100% polyester. Sleeping surface app. 190 x 110 cm. **21089 619,-**

Freight flat rate high roof: For shipment within Germany
 or collection from the dealer **226 203,-**

Ergoline high roof for long wheelbase

With parts certificate*. High roof bed possible. Standing height approx. 205

cm. Classic roof shape. Smooth outer shape. Vehicle elevation: ca. 65 cm.

Window side and rear: max. 70 x 30 cm. Sunroof possible.

Color white **21058 1749,-**

Interior trim



Homely ambience, velor gray. Cladding and insulation (20 mm)

in one. Complete incl. mounting material **21059 1299,-**

Mounting frame with cab cutout for Transporter LWB from 2003 onwards

Advantage: headroom in the driver's cab, easy "walking to the rear".

Integrated bed pad. Not with Sunroof in the cab.

 Left-hand drive		 righthanddrive	
21081	608,83	21081R	599,-

Mounting frame without cab cutout for Transporter LWB from 2003 onwards

 Left-hand drive		 righthanddrive	
21084	469,73	21084R	469,73

High roof bed Volkswagen Transporter LWB

Wooden plate apple incl. foam mattress, about 6 cm thick and cover gray, 100%
 polyester. Sleeping surface about 210 x 120 cm. **18058 890,-**

*only valid with our offered mounting frames. Standard color of the roofs white, illustrations partly show additional equipment. For additional charge, we are happy to paint your vehicle roof in color of your choice. Windows & roof hoods installed in high roofs & shown are not included in scope of delivery.



VOLKSWAGEN T4 - SLEEPING ROOF SUPER FLAT

Short wheelbase, up to YOC. 2003, front high

Pre-assembled, w/ assembly materials & instructions (without bed & mounting frame). With parts certificate*. Standing height with open roof ca. 195 - 245 cm. Vehicle height with roof approx. 200 cm (depending on design and load). Sleeping surface app. 108 x 195 cm. 2 side windows in the tent bellows with mosquito netting, 1 foil window integrated in front. Roof shell color white

21115 3290,-

Matching bed for super flat sleeping roof

Lightweight poplar plywood, tripartite, 2-fold folding, upholstery thickness 40 mm, incl. removable cover (100% polyester)

Sleeping surface: 187x108 cm, color gray 21113 499,-

Bed with gas spring support

Lightweight 15 mm poplar plywood, 3 parts, each with 2 gas dampers and support struts. 40 mm foam with removable polyester cover.

Sleeping surface: 187x108 cm, color gray 21111 599,-

Necessary for body reinforcement:

Mounting frame VW Transporter until 2003, short WB

Mounting frame parts incl. rivets, glue, building instructions.

Roof cutout incl. driver's cab.

Left-hand drive 21003 519,-

righthanddrive 21003R 519,-



Mounting frame

Flat-rate freight for sleeping roof:

For delivery within GER or collection

from specialist dealer 225 104,-



VOLKSWAGEN T4 - SLEEPING ROOF SUPER FLAT

Long wheelbase, up to YOC. 2003



Gas spring assisted roof installation front high. With parts certificate*. Standing height with open roof app. 195 - 245 cm. Vehicle elevation app. 6 cm. Integrated rain gutter. 3 windows in the tent bellows (1 of them with foil), mosquito net with zipper. Sleeping surface app. 200 x 120 cm. Cover 100% polyester. Glass sliding roof and solar cell possible. Concealed mounting of active rail without add. vehicle increase in height possible. Roof shell color white. 21121 3490,-

Inst. frame for sleeping roof super flat

Roof cutout incl. driver's cab cutout

Left-hand drive 21023 559,-

righthanddrive 21023R 559,-

Sleeping roof bed super flat

Wooden top 2-piece (laminated board gray), including foam and cover.

The two-part bed guarantees high freedom of movement in living position.

Sleeping surface app. 197x108 cm. Foam mattress 4 cm.

21112 599,-



Mounting frame

Flat-rate freight for sleeping roof:

For delivery within GER or collection from specialist

dealer 225 104,-



VOLKSWAGEN T4 - SLEEPING ROOF EASYFIT

Short wheelbase, up to YOC. 2003, front high

Vehicle increase by app. 6 cm, roof cutout incl. driver's cab.

Tent bellows 100% cotton. Roof shell color white.

Tent bellows not pretensioned. Suitable for right or left hand drive.

Scope of delivery: sleeping roof w/ tent bellows & subframe (w/o. bed).

21140S 4390,-

Matching bed for Easy Fit sleeping roof front high

Scope of delivery: bed to sleeping roof Easy Fit with foam and cover

(100% polyester).



21140B 729,-





VOLKSWAGEN T4 - LIFTING ROOF / HIGH ROOF

Short or long wheelbase, up to YOC. 2003



VOLKSWAGEN T4 lifting roof super flat

Headroom in the entrance area (with the roof open) app. 190 cm.
Roof installation gas spring assisted. 2 side windows with mosquito netting, 1 foil window integrated in the front.

Incl. Mounting frame. Vehicle elevation app. 6 cm.

Roof dims. app.: L175 x B130 x H9 cm.

Roof cutout approx. L107.5 x W101 cm.

Lifting roof position between B-pillar & C-pillar. Roof shell color white.

Incl. Parts certificate*.

(Delivery time approx. 4-6 weeks)

21210

2190,-

Flat-rate freight charge for lifting roof: For shipment within GER or collection from specialist dealer

227

53,40



High roof Aeroline for short wheelbase

Elegant roof shape. With parts certificate*. Roof dims. app. L297 x B149 x H75 cm. Vehicle elevation app. 64 cm. Headroom app. 210 cm. Windows side and rear max. 70 x 30 cm. Sleeping surface about 185x115 cm, foam thickness 3 cm. Option: concealed active carrier system high roof bed & small sliding roof hatch possible. Roof color white

21005 1699,-

Matching accessories: Active rail 2 m

41300 59,10

Inner shell for Aeroline 20 mm insulation possible.

21006 1389,-

Interior trim set for Aeroline for gluing in

Prefabricated cladding elements for the high roof. 20 mm insulation-material cut, pasted with gray isovelours.

21008 1099,-

Sleeping roof bed

Wooden top 2-piece (laminated board gray), including foam and cover. The two-part bed guarantees high freedom of movement in living position. Sleeping surface app. 197x108 cm. Foam mattress 4 cm.

21112 599,-



High roof Aeroline for long wheelbase

Elegant roof shape. Roof dimensions app. L335 x B149 x H85 cm. Vehicle elevation app. 74 cm. Headroom app. 210 cm. Windows side and rear max. 70 x 30 cm. Option: concealed active carrier system and sliding roof hatch 52 x 54 cm possible. With parts certificate*. Roof color white

21010

1799,-

Inner shell for high roof Aeroline long wheelbase

20 mm insulation possible.

21011

1449,-

Active support system, 1 rail, length 2 m

41300

59,10

*only valid with our offered mounting frames. Standard color of the roofs white, illustrations partly show additional equipment. For additional charge, we are happy to paint your vehicle roof in color of your choice. Windows & roof hoods installed in high roofs & shown are not included in scope of delivery.

VOLKSWAGEN T4 MOUNTING FRAME

TÜV-tested - Bed support integrated - With or without cab cut-out

① **Mounting frame with cab cutout Volkswagen T4**
Roof cutout approx. 284 x 110 cm

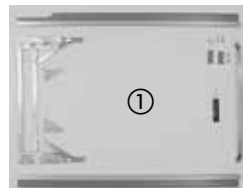

② **Installation frame without cab cut-out Volkswagen T4**
(not for sleeper roof). Roof cut-out approx. 243 x 110 cm



Left hand drive short wheelbase 21003 519,-
Left hand drive long wheelbase 21023 559,-

righthanddriveshort wheelbase 21003R 519,-
righthanddrivelong wheelbase 21023R 559,-

Left hand drive short wheelbase 21004 437,63
Left hand drive long wheelbase 21022 429,-

righthanddriveshort wheelbase 21004R 437,63
righthanddrivelong wheelbase 21022R 429,-



VOLKSWAGEN T3 - SLEEPING ROOF SUPER FLAT

Short wheelbase, YOC. 1980 to 1990



Ready pre-assembled, roof installation front high. Vehicle height with roof is about 2 m. Delivery without sleeping roof bed, foam and cover. Vehicle elevation: app. 11 cm. Standing height with the roof open: ca. 200 - 240 cm. Roof cutout: approx. 109 x 103 cm.

With parts certificate*. Roof shell color white, surface smooth
20136 3290,-

Luggage tray for sleeping roof

Forms a harmonious roof finish at the front and provides further storage space. A pack sack, for example, can be stowed in the trough.

Color: white, surface smooth 20137 890,-

Sleeping roof bed - bed area: approx. 185 x 112 cm

With foam (approx. 3 cm thick) and cover (100% polyester) in classic gray.
20121 629,-

Freight flat rate sleeping roof: For delivery within Germany or collection from the dealer 225 104,-



VOLKSWAGEN T3 - HIGH ROOF AEROLINE

Short WB, up to YOC. 1990



Aerodynamic shape, high quality, proven for years. Roof dims. app. L344 x W142 x H77 cm. Vehicle elevation app. 64 cm. Headroom app. 202 cm. Rear window approx. 70 x 40 cm, side approx. 60 x 18 cm. Sliding roof hatch approx. 52 x 54 cm. With parts certificate*. Color: White 20000 1649,-

Mounting frame for aeroline roof

Wooden frame for roof cutout L110 x W104 cm 29440 80,20

Flat-rate freight charge for high roof:

For delivery within Germany or collection from the dealer you will receive on request.



VOLKSWAGEN T3 - LIFTING ROOF SUPER FLAT

Until YOC. 1990



The inexpensive alternative. Headroom in the sliding door area. Easy and quick installation. Roof dimensions app. L161 x W128 x H11 cm. Vehicle elevation app. 5 cm. Headroom with roof open: interior plus app. 45 cm. Roof cutout app. L110 x W104 cm. Incl. Wooden mounting frame, cladding profile for cutout and small parts. With parts certificate*. Roof shell color white 20200 1990,-

Freight flat rate lifting roof:

For shipment within Germany or collection from the dealer 227 53,40



*only valid with our offered mounting frames. Standard color of the roofs white, illustrations partly show additional equipment. For an additional charge we paint Your vehicle roof also gladly in your desired color. Windows & roof hoods installed in high roofs & shown are not included in scope of delivery.





VOLKSWAGEN CADDY 5 - sleeper roof

Long wheelbase, YOC. as of 08/2020



Sleeping roof super flat for Caddy V Maxi from YOC. 08/2020, rear high

Sleeping roof offers an airy roof bed in "upper floor" with a sleeping area of app. 195 x 100 cm and of course the so valuable standing height in living area, which gains feeling of space enormously. The at least equally important parking garage suitability is given by an overall height of the vehicle of app. 193 cm.

Release in preparation.

Reinforcing frame	22117136	3149,-
	22117R01	699,-

Sleeping roof bed

Sleeping surface app. 195 x 100 cm, cushion thickness 4 cm

22124	649,-
--------------	--------------



VOLKSWAGEN CADDY 4 MAXI - SLEEPER ROOF

Long wheelbase, YOC. 2008 to 08/2020



Sleeping roof for Caddy Maxi up to YOC. 08/2020 with long wheelbase transforms your Caddy into a "mini camper" with comfortable standing height. Headroom front 170 cm, rear 205 cm. Comfortable sleeping roof bed for 2 persons. Sleeping surface app. 193 x 93 cm, foam thickness 4 cm. The front spoiler provides good aerodynamics and reduces wind noise. 3 windows in the tent bellows provide fresh air. Vehicle height w/ sleeping roof app. 196 cm.

	2211801	3740,-
Reinforcing frame	22122	519,-
Sleeping roof bed	22123	649,-

Fairing frame for all Caddy Maxi until 05/2015 and Caddy Maxi station wagon from 06/2015 (commercial vehicle, without rear plastic interior trim), 4-piece, hard fiber uncovered + aluminum profiles

10560	229,-
--------------	--------------

Trim frame for Caddy Maxi from 06/2015 - 2020

with shaped headliner (passenger car), only aluminum profiles

10561	169,-
--------------	--------------



Attention: For vehicles with head airbag in the second row of seats, the roof mounting is not approved by Volkswagen!



FORD TRANSIT CUSTOM / TOURNEO CUSTOM V710 - EASYFIT SLEEPING ROOF

Length L1 (5000 mm), from year of construction 2023



EasyFit sleeper roof, high front installation for Ford Custom V710, L2 H1 (length 5 m, height 2 m), tent bellows tensioned.

Scope of delivery:

GRP frame, spoiler, installation frame.

Sleeping roof bed available separately.

Available from Q1 2024



All information about the product



FORD TRANSIT CUSTOM - SLEEPING ROOF SUPER FLAT

Length L1 (4972 mm), from YOC. 07/2013 to 2022



Roof installation front high. 3 windows in the tent bellows, mosquito nets removable. Bed dims.: app. 203 x 130 cm. Headroom with roof open: 205 cm front, 150 cm rear.

Tent bellows mounted. Without frame, without bed. Separately available mounting frame required for reinforcement. Individual acceptance required.

Without cab cutout.

22115 3890,-

With cab cutout.

221150 3890,-

Sleeping roof bed, front high, for sleeping roof without cab cutout for sleeping roof with cab cutout

22116B 599,-

22115B 689,-

Installation frame

without cab cutout, front high

20113 1399,-

with cab cutout, front high

20114 1499,-

A manufacturer's release is available for the roof without cab cutout.

Freight flat rate sleeping roof: For delivery within Germany or collection from the dealer

225 104,-



FIAT SCUDO - SLEEPING ROOF SUPER FLAT

Length L2 (5135 mm), YOC. 2006 to 2016



Sleeping roof up front. Vehicle height app. 200 cm. Sleeping roof w/ front part, roof shell in gelcoat. A large window in front (can be used as an emergency exit). On the side 2 smaller windows with mosquito net.

Without parts certificate. Individual acceptance required.

Roof shell color white.

28140 3290,-

Installation frame set with cab cutout

28141 559,-

Sleeping roof bed

Sleeping surface 200 x 120 cm. Made of 15 mm poplar plywood (light) in light-gray laminate. 1-piece and gas spring supported. Mattress made of 3 cm foam with gray cover (100% polyester), cleanable.

28142 649,-

Freight flat rate sleeping roof: For delivery within Germany or collection from the dealer

225 104,-

*only valid with our offered mounting frames. Standard color of the roofs white, illustrations partly show additional equipment. For an additional charge we paint Your vehicle roof also gladly in your desired color. Windows and roof hoods installed in roofs and shown are not included in scope of delivery.



MERCEDES-BENZ VITO - EASYFIT SLEEPER ROOF



For Mercedes-Benz Vito, V-Class, Metris, Valente, V-Class, long, body length 514 cm/L2

About 10 cm more Legroom thanks to new comfort scissors

Easy-Up function for easy Open and close



Sleeping roof EasyFit for Mercedes-Benz Vito long, body length 514 cm, L2, installation front high

Part number 23160XXX, Base price 4690.-

Gas spring assisted roof installation front high. Ready pre-assembled, incl. front spoiler. 2 side windows (mosquito net removable), 1 foil window integrated in the front. Vehicle height incl. roof app. 197 cm. Standing ht. app. 170 - 222 cm. Tent bellows 100% polyester. Roof shell color white. **Incl. Parts cert.**

1. Select the shell type:

1.1 tray EasyFit Standard front high 23160XXX 4690,-

2. Select the type of EasyFit frame, suitable for:

2.1 Transporter/station wagon vehicles Series 0,-

2.2 Vehicles w/ molded headliner/climate headliner Surcharge 70,-

3. Select the shutter type:

3.1 strap closure: Series 0,-

4. Choose the tent bellows type and color

4.1 Tent bellows standard: Series 0,-

4.2 Tent bellows OpenSky: Surcharge 199,-

5. Special equipment solar panel

5.1 version standard: without solar module Series 0,-

5.2 version with bonded solar panel 120-130W Surcharge 999,-

6. Active beam profile

6.1 version standard: w/o. active support profile Series 0,-

6.2 active beam profiles installed Surcharge 369,-

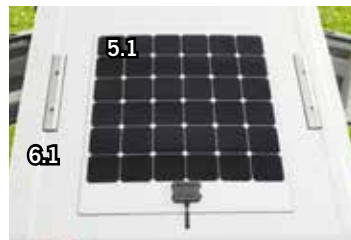

SIUXURY sleeping roof bed, incl. plastic spring system

Disc spring system for incr. sleeping comfort, ventilated from below. 4 cm comfort padding, sleeping surface 200 x 120 cm. Cover 100% polyester, removable and cleanable

23162 729,-



MERCEDES-BENZ VITO - SUPERFLAT SLEEPER ROOF



For Mercedes-Benz Vito/Viano compact/long/extra long, from YOC. 2004 (also from YOC. 2014)



Vito/Viano compact/long/extra long

Sleeping roof Vito/Viano compact Roof set-up front high. Vehicle length 4895 mm/L1. 2 side windows (mosquito net removable), 1 foil window integrated in the front. Vehicle elevation app. 7 cm. Tent bellows 100% polyester.

With parts cert.* Roof shell color white 23140 3090,-

Sleeping roof Vito/Viano long Identical w/ sleeping roof compact.

Vehicle length 5140 mm/L2. 23130 3390,-

Sleeping roof Vito/Viano extra long Identical w/ sleeping roof compact.

Vehicle length 5370 mm/L3. 23150 3590,-

Sleeping roof bed 15 mm poplar plywood in gray, laminate. Foam 6 cm and cover gray. 100% polyester. Sleeping surf. app. 200 x 120 cm

Vito/Viano compact 23141 759,70

Vito/Viano long 23131 759,70

Vito/Viano extra long 23151 759,70

Installation frame Vito/Viano compact/long/extra long incl. cab cutout. Cutout size approx. 210 x 105 cm. Last 50 cm of original sheet metal roof is retained for roof suspension cabinet support. 23132 534,-

Freight flat rate sleeping roofs: For delivery within Germany or collection from the dealer 225 104,-

*only valid with our offered mounting frames. Standard color of the roofs white, illustrations partly show additional equipment. For additional charge, we will paint your vehicle roof in color of your choice.





MERCEDES-BENZ VITO - SUPERFLAT SLEEPER ROOF



Until YOC. 2003

Super flat sleeping roof for Mercedes-Benz Vito until YOC. 2003. Roof placement at the front high. 2 side windows (mosquito nets removable). Vehicle elevation app. 11.5 cm. Vehicle height with roof app. 198 cm. Standing height (roof open) app. 185 - 230 cm. Tent bellows 100% polyester. With parts cert.* Roof shell color white

Front high, with belt closure	23115	4190,-
Sleeping roof bed w/ foam st. and cover gray 100% polyester. Sleeping surface about 200x120 cm Front high	23116	699,-
Installation frame incl. cab cutout. Front high	23117	555,33

Freight flat rate sleeping roof: For delivery within Germany or collection from the dealer	225	104,-
---	------------	--------------



MERCEDES-BENZ VITO - HIGH ROOF ERGOLINE

For Mercedes-Benz Vito / Viano from YOC. 2004 (also suitable from YOC. 2015)

Vehicle length 4993 mm. Classic, smooth roof shape. Glass fiber reinforced plastic shell. Vehicle elevation app. 65 cm. Bed install. possible. With parts cert.* Roof shell color white

Interior trim set Vito/Viano	23127	1149,-
Installation frame incl. cab cutout. Cutout size approx. 210 x 105 cm. Last 50 cm of original sheet metal roof is retained for roof suspension cabinet support.	23132	534,-
High roof bed for Ergoline high roof	23128	866,70



MERCEDES-BENZ SPRINTER - HIGH ROOF ERGOLINE

For Mercedes-Benz Sprinter from YOC. 2006/VW Crafter YOC. 2006-2017, medium wheelbase

Standing height in roof ca. 232 cm. Classic, smooth roof shape. Glass fiber reinforced plastic shell. Vehicle elevation app. 66 cm. Bed install. possible. Without parts cert*. Dims. app. 403 x 164 x 75 cm

Roof shell color white	23092	2399,-
Interior trim set Crafter/Sprinter	23046	1399,-
Mounting frame without cab cutout. Cutout size approx. 293 x 146 cm.	23094	416,23
High roof bed for Ergoline high roof	23047	694,43

Kit. Includes foam and cover.

Freight flat rate high roofs: For delivery within Germany or pickup from the dealer is available on request.



*only valid with our offered mounting frames. Standard color of roofs white, illustrations partly show additional equipment. For additional charge we paint Your vehicle roof also gladly in your desired color. Windows and roof hoods installed in high roofs and shown are not incl. in scope of delivery.

RENAULT TRAFIC - SLEEPING ROOF EASYFIT

For Trafic, Nissan NV300, Fiat Talento (from VOC. 8/2014), Opel Vivaro B (until VOC. 3/2019), short or long wheelbase

- With front window and 2 side windows
- The front can be opened with zipper
- Side windows with mosquito nets
- Sky (100% Polyester)
- Tent bellows gray (100% polyester)

- Mounting frame included
- Roof shell color white
- Gas spring assisted
- With parts cert.*



EasyFit V-Tec Sleeping Roof for Renault Trafic SWB, front high installation. Headroom 175 / 227 cm.
With safety lock **2806016** **6390,-** 

The EasyFit V-Tec sleeping roof has a sandwich construction of inner and outer shell with integrated reinforcements.

The safety lock is screwed through the shell. Elegant smooth surface inside and outside, easy to clean. Incl. Mounting frame

Sleeping roof bed LUXURY, incl. disc spring system
 Disc spring system for increased sleeping comfort, ventilated from below. Sleeping surf. app. 190 x 140 cm, upholst. dims. app. 186 x 130 x 4 cm. With aperture for entry opening. **280720** **749,-**

Sleeping roof EasyFit for Renault Trafic SWB, installation front high 

With strap closure **2806011** **5690,-**
with QuickLock locking system **2806012** **6190,-**

Sleeping roof bed LUXURY, incl. disc spring system
 Disc spring system for increased sleeping comfort, ventilated from below. Sleeping surf. app. 190 x 140 cm, upholst. dims. app. 186 x 130 x 4 cm. With aperture for entry opening. **280720** **749,-**



Sleeping roof EasyFit for Renault Trafic long wheelbase, installation front high 

With strap closure **2806111** **6690,-**

Sleeping roof bed LUXURY, incl. disc spring system Disc spring system for incr. sleeping comf., ventilated from below. Sleeping surf. app. 190 x 140 cm, upholst. dims. app. 186 x 130 x 4 cm. Orifice for entry opening not suitable for LWB **280720** **749,-**

Sleeping roof EasyFit for Renault Trafic long wheelbase, installation rear high 

With strap closure **2806113** **6790,-**
Sleeping roof bed, classic
 Sleeping surface 215 x 130 cm incl. cushion **28069** **715,83**

Freight flat rate sleeping roofs: For delivery within Germany or collection from the dealer **225** **104,-**

*only valid with our offered mounting frames. Standard color of roofs white, illustrations partly show additional equipment. For additional charge, we also paint your vehicle roof in color of your choice. Windows & roof hoods installed in roofs & shown are not included in the scope of delivery.



RENAULT TRAFIC SWB - SUPERFLAT SLEEPER ROOF

For Renault Trafic, Opel Vivaro, Nissan Primastar, SWB, up to YOC. 6/2014

Gas lift assisted, roof mounted front high. 2-piece . with front window, active rail can be mounted, w/o. additional acc. Vehicle increase. Mosquito net with zipper. The front can be opened with zipper. Vehicle height w/ roof about 200 cm. Sky (100% polyester), tent bellows gray (100% polyester). With parts cert.*. Roof shell color white **280502** **3290,-**
2-section bed, 15 mm wooden top (high freedom of movement in living position). Sleeping surf. app. 188 x 132 cm.

With 4 cm thick foam and gray cover (100% polyester).
Incl. Bed pads **28054** **799,-**

Mounting frame

with cab cutout. TÜV approval. Bed pad integrated. Headroom in the cab, easy "walk behind". Roof cutout app. 240 x 108 cm. Not with Sunroof in the cab

280482 **789,-**

Freight flat rate sleeping roof: For delivery within Germany or collection from the dealer

225 **104,-**



RENAULT TRAFIC - LIFTING ROOF EASYFIT ULTRAFLAT

For Renault Trafic, Nissan NV300, Fiat Talento (from YOC. 2014) / Opel Vivaro B (until YOC. 3/2019)



New elevating roof with EasyFit subframe and integrated front spoiler. The EasyFit subframe allows perfect adaptation to the roof structure of the vehicle. The roof provides standing height in an area of 98x92 cm. Between B-pillar and C-pillar 50 cm more height with roof open, 5 cm with roof closed. Vehicle height with closed roof approx. 203 cm.

HD Ultra Flat for Renault Trafic **2022111** **2690,-**

Flat-rate freight charge for lifting roof: For shipment within GER or coll. from specialist dealer

227 **53,40**



*only valid with our offered mounting frames. Standard color of roofs white, illustrations partly show additional equipment. For additional charge, we also paint your vehicle roof in color of your choice. Windows & roof hoods installed in roofs & shown are not included in the scope of delivery.

SLEEPING ROOF FOR MAXI VANS

For 2 more sleeping places in your camper



Sleeping roof Ducato II with chic front spoiler in black. High aerodynamics, less wind noise.



- The sleeping roof offers 2 more sleeping places
- Easy, manual set up due to gas spring
- High comfort scissors with app. 45 cm legroom
- Roof bed-Sleeping surf. up to 200 x 120 cm
- Equipped with 3 windows as standard, 2 of them incl. mosquito nets
- Mounting of an awning possible

Sleeping roof for Maxivan offers 2 additional comfortable sleeping places in your van.

It is always delivered consisting of 3 parts to make the assembly as easy as possible: Roof shell including pre-assembled mechanics and tent bellows, the GRP subframe and the front spoiler.

GRP subframe is glued to the body, the roof shell is mounted on it and the tent bellows is attached in the classic way with tent bellows strips.

The GRP frame requires a mounting surface of 275 x 145 cm. The front spoiler requires a body length of approx. 45 cm, but can also be mounted in the area of the front roof slope or omitted, as long as it is ensured that the airstream is directed over the roof.

Entire assembly takes place above roof sheet, as a roof cutout is sufficient, e.g. the hatch opening of a Hekis. Roof locking with straps. Bed cushion lies directly on roof sheet in under-ventilated position.



Access hatch with access ladder



45 cm legroom in the roof bed for high sleeping comfort

Sleeping roof Fiat Ducato* from length L2, H2

The positioning of the roof is intended so that an existing cutout from a heki directly behind the cab can be used as a hatch.

The GRP frame then ends exactly in area of transverse bead of roof sheet. Roof hatches, located behind transverse bead, can be retained. The positioning results in a roof bed length from the cutout of 180 cm, extendable to 2 m with an additional part if required (optional). Body height app. 18 cm.

Simultaneous installation of awning is possible thanks to awning adapter cutouts on sleeping roof. If an awning is not installed, an optionally available cover set can be inserted into the recesses.

Sleeping roof for Fiat Ducato L2 H2, White	28066906	5290,-
Sleeping roof for Fiat Ducato L4 H2, White	28066902	5190,-
Sleeping roof for Fiat Ducato L4 H2, Black	28066903	5690,-

Roof bed Maxivan Ducato		
Bed cushion 120 x 180 cm	280670	438,70

Bed extension Maxivan Ducato		
Sliding board with bed cushion 120 x 20 cm, for extending the roof bed to 2 m sleeping length	280672	149,-

Access ladder for easy access to the roof bed	42122	199,-
--	--------------	--------------

Cover set for awning adapter cutouts	28066-2	Price on demand
---	----------------	------------------------

*also suitable for Citroën Jumper, Peugeot Boxer from YOC 2006, Opel Movano from YOC. 2021, Ram Promaster from YOC. 2009



More maxi van sleeping roofs:

Sleeping roof Volkswagen Crafter from YOC. 2017, H3 vehicle height 262 cm, at 6 m vehicle length

The roof is positioned so that the hatch can be accessed in the roof hatch area behind the spar in the sliding door area. Body height app. 24 cm.

28066541	5490,-
-----------------	---------------

Sleeping roof Mercedes-Benz Sprinter from YOC. 2006, at 6 m vehicle length body height app. 22 cm.

28066361	5490,-
-----------------	---------------

NEW: Ford Transit V363 L3 H2 sleeper roof, vehicle H 2411 mm, 6 m vehicle L

28066721	5290,-
-----------------	---------------

Universal sleeping roof for large vans e. g. Renault Master, Ford Transit or Hyundai H 350.

Note: Lower frame, spoiler and, if necessary, frame must be adapted.

28066001	5390,-
-----------------	---------------

Roof bed Volkswagen Crafter, Mercedes-Benz Sprinter and Universal suitable for the roofs listed above

Bed cushion 120 x 200 cm, ventilated	28067	438,70
--------------------------------------	--------------	---------------

UNIVERSAL ELEVATING ROOFS

For vehicles for which REIMO does not offer special roofs



More
Housing quality
through a
Lifting roof

Lifting roof ultra flat EasyFit for Renault Trafic, Opel Vivaro, Nissan NV300, Fiat Talento LWB from YOC. 2014 on page 135



Notes for the self-builder: TÜV individual acceptance required

- Provided that no bows have to be cut or injured in the cut-out area, there are usually no additional requirements for conversion.
- If bows are removed or relocated, the vehicle manufacturer's installation guidelines must always be observed.
- This intervention should be discussed in advance with the expert of the TÜV, who will also accept the vehicle later.
- Particular attention must be paid to the force-locking connection to the adjoining roof bows.
- Example: square tube 40 x 20 x 1.5 mm with lugs to the transoms, or bent sheet metal profile that absorbs the body weakening through the cutout.
- The modification made will invalidate the vehicle's operating permit.
- The conversion of vehicle must be presented to official expert in accordance with §19/STVZO. (Change of vehicle documents)
- A spoiler profile / wind deflector in front of elevating roof is useful for vehicles that reach over 140 km/h or shape of roof dictates insufficient aerodynamics.



Lifting roof T6/T5 on pg. 123



Lifting roof T4 on pg. 126



Lifting roof T3 on pg. 127

- Universally applicable
- Gas spring assisted
- Set up in parallel
- Mechanics for vehicles with very low or higher roof camber
- Surface dyed white, paintable
- Increasing ht. of interior by about 45 cm
- Ventilation: 3 closable tent fabric windows with mosquito nets
- Tent bellows gray, 100% cotton
- Incl. Wood mounting frame

Lifting roof for panel vans/vans (e.g. Ford Transit Custom, Renault Trafic, Opel Vivaro)

Lifting roof EasyFit Universal w/ integrated spoiler

Height of lifting roof closed: 50-150 mm, height open: 445 mm. Lifting roof Easy Fit subframe is not adapted to the body. Roof shell size: W 1300 x L 1700 mm Roof cut-out size: W 1040 x L 970 mm **2022101 2590,-**



Item no. 2022101

Lifting roof for minicamper

(Kangoo, Berlingo, etc.)

Lifting roof Universal Standard

For vehicles with small roof area. Roof size approx. L145 x W108 x H17 cm, roof cutout approx. L107.5 x W88.5 cm or smaller. Distance of the mechanism approx. 92 cm

Roof support angle 90° **20212 1890,-**



Item no. 20212

Lifting roof with normal shell for roofs with normal width

Lifting roof universal super flat, roof support angle 90°

Mechanics for vehicles w/ slight curvature of roof. Roof size app. L175 x B132 x H14 cm. Dist. of mechanism about 107 cm.

Roof cutout approx. L107.5 x W101 cm or smaller **20210 1990,-**

Roof cutout approx. L130 x W104 cm or smaller **202100 2090,-**



Item no. 202100

Freight flat rate lifting roof: For shipment within Germany or collection from the dealer **227 53,40**
Subject to technical changes.W.

As **wind deflector**, we recommend mounting spoiler profile: **29365 (1.6 m bar)** in front of super flat lift roofs

REIMO ROOF VARIANTS

which REIMO roof fits your vehicle



Sleeping roof (SD)

- Suit. for underground parking (ht. depends on model)
- Additional sleeping places possible
- Inclined installation
- Standing height in living area
- 2 large closable mosquito net windows
- Roof rack possible (30 kg)
- Large foil windows
- Solar cell possible
- Vehicle elevation app. 7-15 cm



High roof (HOD)

- All-weather
- Standing height in living area
- Additional storage space possible
- Additional sleeping places poss.
- Aerodynamic shape
- Ventilation through skylight possible
- Roof rack possible
- Sunroof / hood possible
- Vehicle elevation app. 45-75 cm



Lifting roof (HD)

- Inexpensive
- Headroom in living area - 45 cm additional on ca.1 m length
- Good ventilation (3 closable mosquito net windows)
- Setting up parallel
- Universal possible for many vehicles
- Vehicle elevation app. 6-12 cm

Welches Reimo Dach passt auf Ihr Fahrzeug (Die Ziffer im Kreis steht für die Fahrzeuglänge)																		
Hersteller	Typ	Baujahr	baugleich	SD Easyfit hinten hoch	SD Easyfit vorne hoch	SD superflach vorne hoch	SD superflach hinten hoch	SD MaxiVan*	HOD Aeroline	HOD Sportline	HOD Ergoline	Hubdach	Fahrzeuglänge (Radstand) in mm					
													Höhe ohne Dach ca. m	①=L1	②=L2	③=L3	④=L4	
Citroen	Berlingo	2018-	14	Ⓢ									1,9	4403(R2785)	4753(R2797)	-	-	
	Spacetourer	2016-	12		②							Uni*	1,9	4606(R2925)	4956(R3275)	5308(R3275)	-	
	Jumpy	2016-	12		②							Uni*	1,9	4606(R2925)	4956(R3275)	5308(R3275)	-	
	Jumper	1994-2006	1									Uni*	2,1	4749(R2850)	5099(R3200)	5599(R3700)	-	
Fiat	Jumper	2006-	13					②③④				①②	2,5	4963(R3000)	5413(R3450)	5998(R4035)	6363(R4035)	
	Fiat Scudo	2006-2014				②*							2	4805(3000)	5135(3122)	-	-	
	Ducato	1994-2006	1									①②	2,1	4749(R2850)	5099(R3200)	5599(R3700)	-	
	Ducato III	2006-	13					②③④					2,5	4963(R3000)	5413(R3450)	5998(R4035)	6363(R4035)	
Ford	Talento	2016-	8	Ⓢ	①②							①②	2	4999(R3098)	5399(R3498)	-	-	
	Transit Custom	2013-				①						Uni*	2	4972(R2993)	5339(R3300)	-	-	
Hyundai	H1	2008-			①*							Uni*	1,9	4685(R2800)	-	-	-	
Mercedes	Vito W447	2014-	11		②	①②③					②	Uni*	1,9	4748(R3200)	5140(R3200)	5370(R3430)	-	
	Viano W447	2014-	11		②	①②③					②	Uni*	1,9	4748(R3200)	5140(R3200)	5370(R3430)	-	
	V-Klasse/EQV W447	2014-	11		②	①②③					②	Uni*	1,9	4748(R3200)	5140(R3200)	5370(R3430)	-	
	Vito (W/V639)	2003-2013	6			①②③					②	Uni*	1,9	4763(R3200)	4993(R3200)	5223(R3430)	-	
	Viano	2003-2013	6			①②③					②	Uni*	1,9	4748(R3200)	4993(R3200)	5223(R3430)	-	
	Vito (W638)	1996-2003	5			①						Uni*	1,9	4660(R3000)	-	-	-	
	V-Klasse	1996-2003	5			①					①	Uni*	1,9	4660(R3000)	-	-	-	
	Sprinter (VS30)	2018-						②③④					2,6	5267(R3259)	5932(R3924)	6967(R4325)	7367(R4325)	
Nissan	Sprinter (NCV3)	2006-2018	4					②③④			②	Uni*	2,6	5245(R3250)	5910(R3665)	6945(R4325)	-	
	Sprinter (T1N)	1996-2006	3							①②	①②③	Uni*	2,4	4889(R3000)	5639(R3550)	6589(R4025)	-	
	NV300	2014-	8	Ⓢ	①②		②					Uni*	2	4999(R3098)	5399(R3498)	-	-	
Opel	Combo	2018	14	Ⓢ									1,9	4403(R2785)	4753(R2797)	-	-	
	Primostar	2001-2013	7				①					Uni*	2	4782(R3098)	5182(R3498)	-	-	
	Vivaro X82	2014-	8	Ⓢ	①②							①②	2	4999(R3098)	5399(R3498)	-	-	
	Vivaro	2001-2013	7			①						Uni*	2	4782(R3098)	5182(R3498)	-	-	
Peugot	Rifter	2018-	14	Ⓢ									1,9	4403(R2785)	4753(R2797)	-	-	
	Traveller	2016-	12		②							Uni*	2	4606(R2925)	4956(R3275)	5308(R3275)	-	
	Expert	2016-	12		②							Uni*	2	4606(R2925)	4956(R3275)	5308(R3275)	-	
	Boxer	1994-2006	1									①②	2,5	4749(R2850)	5099(R3200)	5599(R3700)	-	
RAM	Boxer II	2006-	13					②③④				Uni*	2,5	4963(R3000)	5413(R3450)	5998(R4035)	6363(R4035)	
	Promaster	2009-	13					②③④				Uni*	2,5	4963(R3000)	5413(R3450)	5998(R4035)	6363(R4035)	
Renault	Traffic X82	2014-	8	Ⓢ	①②							①②	2	4999(R3098)	5399(R3498)	-	-	
	Traffic	2001-2013	7			①						Uni*	2	4782(R3098)	5182(R3498)	-	-	
Toyota	ProAce	2016-	12		②							Uni*	1,9	4606(R2925)	4956(R3275)	5308(R3275)	-	
	ProAce City	2018-	14									Uni*	1,9	4403(R2785)	4753(R2797)	-	-	
	Hiace H200**	2004-			①*							Uni*	1,9	-	4695(R2570)	-	-	
	Hiace / Granvia	1995-2002						①*				Uni*	1,9	4750(R2985)	-	-	-	
VW	Regius	1997-2002						①*				Uni*	1,9	4750(R2985)	-	-	-	
	Caddy (Maxi)	2015-2020	11				②					Uni*	1,9	4408(R2682)	4878(R3006)	-	-	
	Caddy (Maxi)	2003-2014	11				②					Uni*	1,9	4406(R2681)	4876(R3006)	-	-	
	Caddy (Maxi)	2021-					②	④*				Uni*	1,9	-	4878(R3006)	-	-	
	T6, T6.1	2015-	9	①②	①②	①②	①②				①	①②	①②	2	4892(R3000)	5292(R3400)	-	-
	T5	2003-2014	9	①②	①②	①②	①②				①	①②	①②	2	4892(R3000)	5292(R3400)	-	-
	T4	1990-2003			①	①②	①②					①②	①②	2	4707(R2920)	5107(R3320)	-	-
	T3	1979-1990/92				①						①	①	1,9	4600(R2460)	-	-	-
Crafter	Crafter	2006-2016	4					②③④			②	Uni*	2,6	5245(R3250)	5910(R3665)	6945(R4325)	7340(R4325)	
	Crafter	2017-						②③④				Uni*	2,6	-	5986(R3640)	6836(R4490)	7391(R4490)	
	LT2	1996-2006	3							①②	①②③	Uni*	2,4	4889(R3000)	5639(R3550)	6589(R4025)	-	

*=Einzelabnahme erforderlich, derzeit kein Teilgutachten/Herstellerefreigabe vorhanden. **=kein deutsches Modell

⚡= Teilgutachten in Arbeit

Baugleich heißt: gleiches Dach passt // Achtung, bei Kopfairbags in der Regel kein Dacheinbau möglich

Alle Angaben ohne Gewähr, Längenbezeichnungen L1-L4 können typspezifisch von Herstellerbezeichnungen abweichen

Alle Angaben nach bestem Wissen ohne Gewähr, Stand August 2022

ACC. FOR SLEEPING ROOFS

Short and long wheelbase



Weather protec. hood Climacover

Ideal protection from rain, snow, ice and dirt. With windows and vents. Mounting over the complete roof.

Climacover for Volkswagen Transporter 6/5 from year 2003

For SWB, Easy Fit roof and California, front high	37391	499,-
For LWB, Easy Fit roof, front high	37394	559,-
For SWB, sleeping roof super flat, front high	37393	479,-
For SWB, sleeping roof SCA 194, front high	37360	519,-

Climacover for EasyFit roof front high w/ high scissors as of 2021

For VW T5/T6 SWB/California/California Beach as of 2003	373941	559,-
For VW T5/T6 LWB	373940	499,-
For Mercedes-Benz Vito long	373942	559,-

NEW: Climacover for Pössl Campster with SCA roof from 2006 **373943** **559,-**



Sleeping roof tent bellows insulation inside

Protection from intense heat or cold. Can be opened by means of a zipper on the windows. Additional ventilation opening with zipper. Mounting: by means of Velcro strips and Velcro discs (enclosed).

Interior insulation for Volkswagen Transporter 4

For VW T4 SWB, super flat roof front high	37395	489,-
For VW T4 California	37399	459,-

Interior insulation for Volkswagen Transporter 6/5

For SWB, super flat roof, front opening	37396	449,-
For SWB, super flat roof, rear opening	37385	445,-
For SWB, EasyFit SD, front opening	37398	459,-
For LWB, super flat roof, rear and front opening	37397	419,-
For LWB, EasyFit SD, front opening	37388	459,-
For California from 2003, California Beach 06/2010	37389	459,-

Insulation for EasyFit roof front high w/ high scissors from 2021 onwards

For VW T5/T6 SWB	373981	459,-
For VW T5/T6 LWB	373881	449,-
For Mercedes-Benz Vito long	373882	439,-

NEW: for Pössl Campster with SCA roof from 2016 **373883** **479,-**



Tent bellows tension rubber w/ quick release skewer

Thanks to this practical elastic band folds your sleeping roof tent bellows optimally. simply placed around bellows of tent and fixed with the quick release. Individually shortenable, 8 m, Black.

442201 **7,-**



ACC. FOR SLEEPING ROOFS

① Active support rail set installed on the sleeper roof

(please order separately, can be difficult to fit later) Ideal for concealed mounting of a roof rack. 4 pieces of app. 40 cm (mounted).

41320 380,-

② Active support profile 40 cm for retrofitting

Counterpanel visible from inside can be covered with Isovelour (51015). 4 pcs. w/ counter plate, seal & screws

41303 290,-

③ Active supp. profile 198 cm long

For mounting on sleeping/high roofs. Bar undrilled.

1 piece 41300 59,10

Basic equipment for all types of vehic. w/ REIMO active carrier profile

④ Atera Signo fixed carrier ASF - Basic carrier for vehicle roof

- Atera Signo is the perfect base for sports equipment attachments such as ski and bike racks, roof boxes and roof tents
- Complete sets - support legs (4 pcs.) & support tubes (2 pcs.) - pre-assembled in package
- Surface protection thanks to rubberized clamping jaws

Highly stable roof support system for mounting in REIMO active carrier profile. Material: Glass fiber reinforced plastic / aluminum / rubber lips.

Maximum load: 100 kg

Fixed point support ASF 41283 284,-

Suitable adapter kit for mounting the fixed carrier in the Reimo active rail

expected to be available from 2. Quarter 2024 - Item no.: 41308 (Information will follow on www.reimo.com)



ASF with aero profile



Roof rack for REIMO Multirail

Support feet (2 pieces) especially suitable for Reimo Multirail rail, Reimo Active rail and for rain gutter mounting. Max. load 100 kg Pair of support legs: Height 20 cm

41180 104,95

Supp. tube: L 165 cm for above supp. foot. Square tube 32 x 22 mm, black plastic coating. TÜV tested. Before opening the sleeping roof, the roof rack must be removed. Per piece

41125 43,10

NOTE: Order accessories when ordering the sleeping roof. Retrofitting is possible, but usually involves significantly higher costs and technical compromises. Standard color of the roofs white, illustrations partly show additional equipment. Subject to technical changes and printing errors.

SOLAR TECHNOLOGY FOR HIGH & SLEEPING ROOFS

Ultra-flexible high-performance solar modules, factory mounted on sleeping roofs

Ideal for sleeping roofs. The modules are only 3 mm thick and therefore do not affect the vehicle height. The honeycomb structure reduces heating by the sun. Sunpower cells deliver a significant increase in elec. yield even when angle to sun is not optimal.

Solar panel Ultra 130W white flexible version incl. charge controller PRS 300. Dims.: 920 x 800 x 3 mm, glued onto sleeping roof. For all REIMO sleeping roofs exc. Caddy **1SW21 1000,-**

Solar system for Caddy Maxi 110W white flexible design incl. charge contr. PRS 300. Dims.: 1125 x 540 x 3 mm, glued on the sleeping roof. **1SW22 1099,-**



Panels on sleeping roof VW T5/T6 SWB

Panels on Caddy Maxi



Solar module sets for retrofitting for roofs w/ 110-150 watt module output

- **MPPT charge controller incl.**
- **Including roof duct**

Profiflex-110 Set White or Black: Price banger set with the Carbest 110 W solar panel. For example, for light, water pump, occasionally heating

Profiflex-150 Set Black: Set with the Carbest 150 W solar panel. e.g. for light, pump, TV/Sat, heating and possibly compressor refrigerator

Material supp. plate: Blk. modules made of sturdy fiberglass, white modules made of more flexible highly bendable TPT.

All sets with **MPPT charge controller** 12 V/150 W (12.5 A) for gel, AGM, acid or LiFePO4 batteries. 2 separate battery circuits. 2 panels can be connected, standby consumption: 5 mA **TIP:** For bonding the modules on the vehicle roof, we recommend cleaner 29415, primer 294470 and adhesive 294112.

Solar complete set	PF-110 White	PF-110 Black	Square-135 white	PF-150 Pro Black
Module power WP	110 W	110 W	135 W	150 W
Power Wh/day	400	400	400	540
Solar panel	1 x 853170	1 x 853172	1x 853175	1 x 853176
Position controller	851005	851005	851005	851005
Controller power	165 W	165 W	165 W	165 W
Cable gland	85201	85201	85201	85201
Dims. in mm	1125 x 540 x 3	1100 x 540 x 2,5	860 x 800 x 3	1475x540x3
Suitable for	Caddy sleeper roof, high roof	Caddy sleeper roof, high roof	REIMO sleeping roofs	REIMO high roof
Art. No.	85272	85269	85277	85278
Price	369,-	519,-	469,-	599,-

MPPT controllers delivered up to 25% more current than conv. charge controllers in our tests.

ACCESSORIES FOR HIGH ROOFS

① **Aluminum high roof pop-up window** Ideal window for Reimo high roofs or alcoves. Very good ventilation in roof. Mounting on side with sturdy outer frame in silver with a wall thickness of 30-35 mm. Cut-out dim. 460 x 160 mm. During assembly, a wooden subframe (not included) must be mounted. Depending on inst. situation, must be manufactured by customer. **34432 299,-**

Replacement sash for window 34432: 34433 223,-

② **S-4 pop-up window** including inner frame, insect screen and blackout roller blind **31201 399,-**

Window covering profiles

Perfect transition to the interior trim. The profile is cut to the depth of the respective wall thickness, glued or fastened with cap screws (not included).

③ **Inner profile bar**

2m Light gray **38000 17,30**



Sealing compound

For installation of windows, roof hoods, trunk lids and other elements with frames. On the exterior surfaces of motorhomes, vans and caravans.

DEKASEAL 8936 swabable sealant

Color: anthracite 310 ml **50030 18,90**

GP 37,90/ 1 liter

Color: Light gray 310 ml **500306 18,90**

GP 37,90/ 1 liter

Sika Lastomer 710 permanently elastic sealant

Does not harden excessively under UV radiation

Color: White 310 ml **38062 14,50**

GP 35,45/ 1 liter

Color: Black 310 ml **38060 14,50**

GP 35,45/ 1 liter

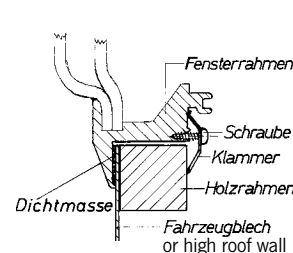

Installation tip window

Insert window from outside into the cutout (approx. 1 mm larger than frame dimension) and screw it against the necessary wooden frame with clamps and screws. Use the above sealant for sealing. Finish inside with interior window trim.

SPARE PARTS FOR SLEEPING ROOFS

Ex.: Sleeping roof (SD) Universal



- ① Seal profile, ② Shears, ③ Gas springs
- ④ Rubber seal for SD scissors 29307 8,99
- ⑤ Top gas spring retainer. Attachment gas spring to SD shell
- ⑥ Gas spring holder at bottom. Fastening gas spring to body
- ⑦ Seal for gas spring holder app. 100 cm 29308 4,67
- ⑧ Plastic handle, Spare part hole spacing 150 mm, gray 293204 2,95
- ⑨ Closing bracket (door retaining cramp) metal, black 29471L 4,20
ditto, plastic brown 40 mm 29425 1,75
- ⑩ Reimo special belt approx. 60 cm long with very robust buckle. 44208 4,90
Closing strap for our sleeping roofs

Spare parts for REIMO sleeping roofs can be found on REIMO website in spare parts store under REIMO/Sleeping roof spare parts.

Roof Part No.	Execution	① Sealing profile	Price per meter	Tent bellows	Price / piece	② Pair of shears	Price per pair	③ Gas spring	Price per piece	⑤ Gas fe-der holder top	Price per piece	⑥ Gas spring holder at bottom	Price per piece
SLEEPING ROOF EASYFIT													
2115001	SD VWT5/6 SWB EasyFit voho	294511	11,-	2929610	480,43	296095	320,-	293120	71,-	293900	23,63	293900	23,63
2115002	SD VWT5/6 SWB EasyFit voho	294511	11,-	2929610	480,43	296095	320,-	293120	71,-	293900	23,63	293900	23,63
2115003	SD VWT5/6 SWB EasyFit hiho	294511	11,-	2929610	480,43	296095	320,-	293120	71,-	293900	23,63	293900	23,63
2115004	SD VWT5/6 SWB EasyFit V-Tec	294511	11,-	2929610	480,43	296095	320,-	293120	71,-	293900	23,63	293900	23,63
2115005	SD VWT5/6 SWB EasyFit V-Tec	294511	11,-	2929610	480,43	296095	320,-	293120	71,-	293900	23,63	293900	23,63
2115008	SD with Easy UP mechanism	294511	11,-	2929611	469,73	296091	248,-	293120	71,-	293900	23,63	293900	23,63
2115009	SD VWT5/6 SWB Comfort Elekt	294511	11,-	2929611	469,73	29609	387,74	293120	71,-	293900	23,63	293900	23,63
2116201	SD T5/6 LWB EasyFit vo.ho.	294511	11,-	2929650	501,83	296095	320,-	293120	71,-	293900	23,63	293900	23,63
2116202	SD VWT5/6 LWB EasyFit white	294511	11,-	2929650	501,83	296095	320,-	293120	71,-	293900	23,63	293900	23,63
2116203	SD VWT5/6 LWB EasyFit white	294511	11,-	2929650	501,83	296095	320,-	293120	71,-	293900	23,63	293900	23,63
2316001	SD Vito Easyfit LWB Harness	294511	11,-	29164	480,43	296095	320,-	293120	71,-	293900	23,63	293900	23,63
2316003	SD Vito Easyfit LWB Harness	294511	11,-	291641	299,-	296091	248,-	293120	71,-	293900	23,63	293900	23,63
2806015	SD Traffic SWB Easyf. V-Tec	294511	11,-	29223	480,43	296095	320,-	293120	71,-	293900	23,63	293900	23,63
2806016	SD Traffic SWB Easyf. V-Tec	294511	11,-	29223	480,43	296095	320,-	293120	71,-	293900	23,63	293900	23,63
2806017	SD Traffic SWB EF V-Tec Ad.	294511	11,-	29223	480,43	296095	320,-	293120	71,-	293900	23,63	293900	23,63
2806111	SD Traffic/Vivaro LWB Easyf	294511	11,-	292241	439,-	296095	320,-	293120	71,-	293900	23,63	293900	23,63
2806113	SD Traffic/Vivaro LWB Hiho	294511	11,-	292241	439,-	296095	320,-	293120	71,-	293900	23,63	293900	23,63
2806401	SD VWT5/6 SWB ultrafla. Ea	294511	11,-	2929612	642,-	296091	248,-	293120	71,-	293900	23,63	293900	23,63
2806501	SD Spacetour. o Roof. vh	294511	11,-	29208	319,93	296091	248,-	293120	71,-	293900	23,63	293900	23,63
21150001	SD VWT5/6 SWB EasyFit voho	294511	11,-	21150Z01	469,-	296091	248,-	293120	71,-	293900	23,63	293900	23,63
21162001	SD T5/6 LWB EasyFit vo.ho.	294511	11,-	2929650	501,83	296091	248,-	293120	71,-	293900	23,63	293900	23,63
28066001	SD Maxivan Comfort Univer	29451	12,10	28066Z01	512,53	296091	248,-	29317	84,48	293900	23,63	293900	23,63
28066361	SD Sprinter roof H2 LÄ.L2	29451	12,10	28066Z01	512,53	296091	248,-	29317	84,48	293900	23,63	293900	23,63
28066541	SD Crafter	29451	12,10	28066Z01	512,53	296091	248,-	29317	84,48	293900	23,63	293900	23,63
28066902	SD Ducato L4H2 white	29451	12,10	28066Z01	512,53	296091	248,-	293170	71,-	293900	23,63	293900	23,63
28051136	SD EF Berlingo 3 white,Gu.	294511	11,-	28051Z16	469,73	296091	248,-	293120	71,-	293900	23,63	293900	23,63
21140S	SD VWT4 SWB Easy Fit white	29451	12,10	29211	544,63	29325	290,-	293120	71,-	293900	23,63	29354	30,-
21162003	SD VWT5/6 LWB Conf. Elect.	294511	11,-	21162Z01	479,-	296091	248,-	293120	71,-	293900	23,63	293900	23,63
21150XXX	SD VWT5/6 SWB EasyFit voho	294511	11,-	21150Z01	469,-	296091	248,-	293120	71,-	293900	23,63	293900	23,63
2806501A	SD Spacet. Adria Comfort Hi	294511	11,-	29208	319,93	296091	248,-	293120	71,-	293900	23,63	293900	23,63

App. 10 m of staple tape (15 x 1.4 mm) is required for fixing tent bellows: 294331 4,25/lfm.

* You will need app. 10 m sealing prof.

SPARE PARTS FOR SLEEPING ROOFS/CANOPIES

Roof Part No.	Execution	① Sealing profile	Price per meter	Tent bellows	Price / piece	② Pair of shears	Price per pair	③ Gas spring	Price per piece	⑤ Gas fe-der holder top	Price per piece	⑥ Gas spring holder at bottom	Price per piece
SLEEPING ROOF SUPER FLAT													
20136	SD VWT3 sfl. white smooth	29450	12,40	29210	469,75	29301	450,-	293120	71,-	29352A	20,-	29375=li 29376=re	23,-
21069	SD VW T5/6 SWB hiho, white	294511	11,-	29269	523,23	296095	320,-	293120	71,-	293900	23,63	293900	23,63
21075	SD VWT5/6 LWB 2pcs.hiho sf	29451	12,10	292891	512,53	296095	320,-	293120	71,-	293900	23,63	293900	23,63
21085	SD VWT5/6 LWB sfl.llvoho	294511	11,-	292981	502,90	296095	320,-	293120	71,-	293900	23,63	293900	23,63
21115	SD VWT4SWB sfl.llvoho,white	29451	12,10	29211	544,63	29325	290,-	293120	71,-	29352A	20,-	29354	30,-
21121	SD VW91 sfl2 LWB white voho	29451	12,10	29213	523,23	29325	290,-	293120	71,-	29352A	20,-	29364	19,-
22115	SD FT SWB as of 07/13 vo.high	294511	11,-	29222	491,13	296095	320,-	293120	71,-	293900	23,63	293900	23,63
23130	SD Vito long version	29451	12,10	29235	491,13	29300	280,-	293120	71,-	293900	23,63	293900	23,63
23140	SD Vito Compact from 04	29451	12,10	29245	480,43	29300	280,-	29385	75,-	293900	23,63	293900	23,63
23150	SD Vito e-long wheelbase	29451	12,10	29240	491,13	29300	280,-	293120	71,-	293900	23,63	293900	23,63
210960	SD VWT5/6 SWB sfl ll voho	294511	11,-	292960	491,13	296095	320,-	293120	71,-	293900	23,63	293900	23,63
221150	SD FT SWB as of 07/13 vo.ho.2	294511	11,-	29222	491,13	296095	320,-	293120	71,-	293900	23,63	293900	23,63
280502	SD Opel Vivaro/Ren.Trafic	29451	12,10	292504	469,73	293271	257,-	29385	75,-	29352A	20,-	29352A	20,-
2211801	SD Caddy Maxi hi.ho white	29450	12,40	29294	448,33	296095	320,-	29385	75,-	293900	23,63	293900	23,63
22117136	SD VW CA5 L2 SF hh GV FH	29451	12,10	22117Z16	459,-	296091	248,-	293120	71,-	293900	23,63	293900	23,63
29365	Spoiler profile 1.6 m (black) for all super flat sleeping roofs		28,00										

Spare parts for lifting roofs

Spare parts for REIMO lifting roofs can be found on REIMO website in spare parts store under REIMO/lifting roof spare parts.

Roof Part No.	Designation	① Seal profile	Price per meter	Tent bellows	Price per piece	② Pair of scissors	Price per pair	③ Gas spring	Price per piece
20211	Universal Superflat 1100 x 1040 / 105°	29451**	12,10	29201	319,93	29306 (105°)	299,-	29310	48,10
20210	Universal Superflat 1100 x 1040 / 90°	29451**	12,10	29203	319,93	29303 (90°)	329,-	29310	48,10
20215	Universal Ultraflat 1 / 105°	29451**	12,10	29201	319,93	29306 (105°)	299,-	29310	48,10
20216	Universal Ultraflat 1 / 90°	29451**	12,10	29201	319,93	29303 (90°)	329,-	29310	48,10
202100	Universal Ultraflat 1 / 1300 x 1040	29451**	12,10	29202	319,93	29303 (90°)	329,-	29310	48,10
20220	Universal Ultraflat 2 / 105°	29451**	12,10	29190	319,93	29306 (105°)	299,-	29310	48,10
20214	Universal Ultraflat 2 / 90°	29451**	12,10	29190	319,93	29303 (90°)	329,-	29310	48,10
20213	Universal Standard / 105°	29451**	12,10	29205	319,93	29306 (105°)	299,-	29310	48,10
20212	Universal Standard / 90°	29451**	12,10	29205	319,93	29303 (90°)	329,-	29310	48,10
20200	Volkswagen Transporter 3	29451**	12,10	29204	319,93	29306 (105°)	299,-	29310	48,10
21185	Volkswagen Transporter 5 Superflat	29451**	12,10	29203	319,93	29303 (90°)	329,-	29310	48,10
21210	Volkswagen Transporter 4 Superflat 2	29451**	12,10	29203	319,93	29303 (90°)	329,-	29310	48,10
2022101	EasyFit Ultraflat Uni	29450	12,40	29206	256,80	29303	329,-	29310	48,10
2022111	EasyFit Renault Trafic	29450	12,40	29206	256,80	29303	329,-	29310	48,10
2118501	EasyFit VW T5/T6 Ultraflat	29450	12,40	29206	256,80	29303	329,-	29310	48,10

App. 5 m of staple tape (15 x 1.4 mm) is required for fixing tent bellows:

294331

4,25/lfm

** You need app. 7 m sealing profile

If you still have gas springs for screws, please order 2x screw ball head 29313 per gas spring.

All gas springs listed are equipped with a ball head mount.

Gas springs should always be replaced in pairs, otherwise the pressure could be different and possibly too weak!



Fastening profile set sleeping roof
4 Active beams app. 40 cm, drilled,
incl. counter plate **41303 290,-**
Active rails universal
198 cm long, drilled four times.
Per piece **41332 219,-**



PLEASE NOTE!

The locking straps for our lifting and sleeping roofs ⑫ article44208 must be checked for damage at regular intervals, at least before each major vacation! Straps where the seam breaks, damaged or torn straps must be replaced immediately.

We recommend (for your own safety) to replace the belts every 5 - 6 years.



REIMO VAN-CONCEPT

SLEEP SEAT- BANKSYSTEMS

In addition to proven REIMO sleeping & sitting bench systems, you will find other bench systems & individual seats from other suppliers in this section. The range is supplemented by belt supports, seat belts and a wide selection of swivel consoles.



▪ CONTENT ▪

ADVANTAGES OF REIMO SLEEPING & SITTING BENCHES	148-149
VARIOTECH® 1000 SINGLE SEATS	150
VARIOTECH® 3100 RIGID SEAT VW T6.1/T6/T5	151
VARIOTECH® 3000 FOR VW T6.1/T6/T5	152
VARIOTECH® 3000 FOR MERCEDES VITO	153
VARIOTECH® 3000 FOR RENAULT TRAFIC	154
VARIOTECH® 3000 FOR FORD TRANSIT	155
SAFETY BELTS	156
SITTING/SLEEPING BENCHES	157-159
SINGLE SEATS/PILOT SEATS	160
BELT TRESTLES	161-163
REVOLVING BRACKETS	164-168
BENCH FITTINGS	169

REIMO SLEEPING & SITTING BENCH SYSTEME

Many advantages for living and sleeping

For Volkswagen Transporter, Mercedes-Benz Vito, Ford Transit, Renault Trafic, Opel Vivaro, Nissan NV300, Fiat Talento



Figure shows V3100

REIMO offers you sleeping/seating bench systems in four different widths from 1155 mm to 1380 mm.

The benches consist of 3 registered seats. The bed is formed with the bench and the integrated rear cushion. The beds have a size depending on the bench or vehicle from about width 126 cm to 160 cm and a length of about 205 cm.

Furthermore, the benches must meet the stability requirements according to European regulations (ECE) to ensure the safety of the seats even while driving. That is why we have our benches extensively tested by TÜV. TÜV approved vehicle mounts are available for various vehicles.

SEAT BENCHES FOR VOLKSWAGEN TRANSPORTER: You want more variable driving positions for your bench seat?

By installing your bench seat at Reimo in the factory, more seating positions are possible while driving. Your dealer will be happy to coordinate this service with us for you. Seating benches can be sold only by specialized dealers trained by Reimo.



Top sleeping comfort due to completely flat sleeping surface. The beds have, depending on bench or vehicle, a width of ca. 126 cm to 160 cm and a length of ca. 205 cm.



Two Isofix mounts provide secure attachment of two child seats. To use it, you only need to open the zipper in the pad.



A storage flap is integrated into the rear shelf. With the seat converted into a bed, it allows quick access from the vehicle interior to travel utensils and luggage in the trunk. This means that it is not necessary to leave the vehicle to access the storage space. Especially practical in bad weather.



The storage space under the rear cushion is 46 cm high. High beverage crates can fit here w/o. any problems. With the rear cushion folded up, bulky items such as a washing machine or refrigerator can also be stowed. By moving the bench seat all the way forward behind the front seats, the storage space is increased accordingly.



Choice of optional bench fascia for more load-through capability or optional bench drawer for more storage space.

REIMO Variotech® V3000 - the sliding and removable bench

- W/ variable living & luggage compt. size
- Several driving pos. possible depending on vehicle & installation
- Safety belts integrated in the backrest
- Top sleeping comfort thanks to completely flat lying surface w/o. annoying belt buckles
- Quick bed construction in a few simple steps without moving the bench
- Good seating comfort on long journeys thanks to ergonomically shaped seat and backrest upholstery.
- Rear cushion can be folded up to expand the trunk loading volume
- Long parts can be loaded through when the optional front panel or drawer is removed
- All seats are equipped with 3-point safety belts
- Isofix mount for up to two child seats
- TÜV tested safety concepts according to ECE 14 & ECE 17
- TÜV app. for motorhome regist. (N1) & passenger car (M1) depending on type
- **Bed width (depending on bench or vehicle): 126 cm to 160 cm, length approx. 205 cm**
- **The retractable headrests do not need to be removed to make the bed**



The Variotech® V3000 with optionally available drawer. This provides add. storage space for shoes, cables or on-board tools, for example. The drawer can be removed for loading long parts. Dims. depending on width of bench: H 17 cm, D 69.5 cm & W from 49.5 - 66.5 cm.

REIMO Variotech® V3100 – the firmly bolted bench

The Variotech® V3100 bench offers the same advantages as the Variotech® 3000 except for shifting. This rigid bench seat is firmly attached to vehicle floor & is available for VW T6/T5 with short as well as long wheelbase. The beds have a width of about 126 to 160 cm and a length of about 190 cm, depending on the bench or vehicle.

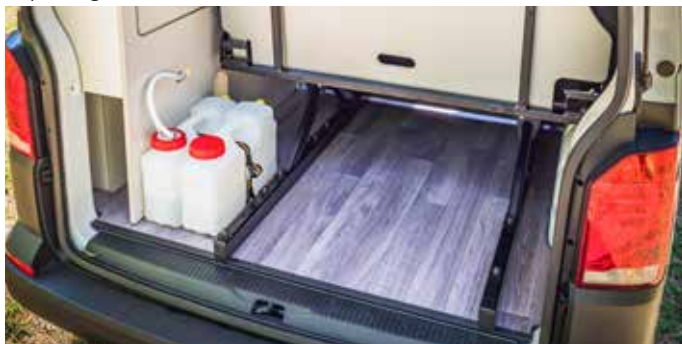

REIMO Variotech® V1000 – comft. individual seats

Comfortable single seats with plenty of legroom become comfort single beds. Dims.: 1x 200x 65 and 1x 190x65 cm. The single beds provide free access to the rear. Storage space app. 86 l. under each individual seat.

From bench to bed in a few seconds using the example of V3000®



1
Raised rear cushion with plenty of storage space in rear



2
Fold down rear cushion, storage space above and below



3
Folded backrest and semi-tilted seat



4
Seat completely swiveled.



5
The headrests remain installed and retract with



6
Finished flat sleeping position with comfort upholstery

See also our Youtube video in channel REIMO Camping/Seating/Sleeping benches for camping buses

VARIOTECH® 1000

Sleeping / single seats

- **Comfortable individual seats w/ plenty of legroom**
- **Comfort single beds 1x 200x 65 and 1x 190x65 cm**
- **Single beds provide free access to the rear**
- **Storage space under single seat app. 86 ltr. per seat**
- **Approval acc. to StVO motorhome**

1 seat incl. safety belt which is attached to the bar of the vehicle (see picture below). The seat is firmly bolted to the vehicle floor. Sitting on profiled seat and sleeping on the smooth back.

Overall width: Driver's side left 660 mm Passenger's side right 680 mm, cushion width 600 mm for both seats.

Sleeping surface: Driver side app. 200 x 65 cm, passenger side 190 x 65 cm,

V1000 sleeper/single seat for Volkswagen Transporter 6.1/6/5

Scope of delivery: Ready made, completely upholstered and pre-assembled with integrated, retractable headrest, safety belt, fastening material, safety belt. Additional pads are included.

Hint: For the additional cushion behind the seats you need a base (not included) which must be manufactured depending on the vehicle itself. The front cushion rests on the turned cab seat. Front panels cannot be supplied by Reimo and must be manufactured by the customer.

Single seat VW T5/T6 driver's side:

Fabric Bricks (2-color, 100% polyester)	5835042	2590,-
Fabric Double Grid (2-color, 100% Polyester)	5835044	2590,-
Classic gray, 2-color 100% polyester	5835000	2590,-
Tassamo T5, 2-colored 100% polyester	5835008	2690,-
Austin T5, 2-color, 100% polyester	5835024	2590,-
Austin T6, 2-colored 100% polyester	5835022	2590,-
Simora T6, 2-color 100% polyester	5835020	2590,-

Single seat VW T5/T6 passenger side:

Fabric Bricks (2-color, 100% polyester)	5835052	2690,-
Fabric Double Grid (2-color, 100% polyester)	5835054	2690,-
Classic gray, 2-color 100% polyester	5835010	2690,-
Tassamo T5, 2-color 100% polyester	5835018	2590,-
Austin T5, 2-color, 100% polyester	5835034	2590,-
Austin T6, 2-colored 100% polyester	5835032	2590,-
Simora T6, 2-color 100% polyester	5835030	2590,-

Sleeping/single seat V1000 for Mercedes-Benz Vito, Renault Trafic, Opel Vivaro B, Fiat Talento

Scope of delivery : Ready made, completely upholstered and pre-assembled with integrated retractable headrest, safety belt, fixing material, safety belt.

Notice: Additional padding for driver's seat and behind the backrest must be made by yourself and cannot be supplied by Reimo. Front panels cannot be supplied by Reimo and must be manufactured by the customer.

Single seats Renault Trafic, Opel Vivaro, Fiat Talento

Fabric Black Patterned, 2-color 100% polyester left	5837040	2279,-
Fabric Black Patterned, 2-color 100% polyester right	5837042	2590,-

Single seats Mercedes-Benz Vito

Fabric Tunja, 2 colors 100% polyester left	5838050	2590,-
Fabric Tunja, 2-color 100% Polyester right side	5838052	2590,-



Fastening the belt to the vehicle spar



VARIOTECH® 3100

Rigid version - not sliding

For Volkswagen Transporter 6.1/6/5

- For vehicles without side plastic trim
- 3 persons sleeping/seating bench fixed
- Ready upholstered for 3 seats incl. rear cushion
- 3 integrated retractable headrests and 3 seat belts
- Isofix attachment points for a maximum of 2 child seats (middle seat cannot be used when a child seat is used)
- Fold up Rear cushion, storage height under rear cushion: 42 cm
- 1 integral foam side panel (size 17: 2 side panels)
- Delivery incl. support feet, please order fixing material separately

Size 8: Total width 1155 mm Pad width 1105 mm

Fabric Classic Grey (2-color, 100% polyester)	5040500	3890,-
Fabric Bricks T6.1 (2 colors 100% polyester)	5040542	4090,-
Fabric Double Grid T6.1 (2-color 100% polyester)	5040544	4090,-
Basaltfront panel	5040580	259,-
Basaltdrawer	5040590	679,-

Size 10: Total width: 1205 mm -Pad width: 1155 mm -

Fabric Classic Grey (2-color, 100% polyester)	5040600	3890,-
Fabric Bricks T6.1 (2 colors 100% polyester)	5040642	4090,-
Fabric Double Grid T6.1 (2-color 100% polyester)	5040644	4090,-
Basaltfront panel	5040680	259,-
Basaltdrawer	5040690	549,-

Size 14: Total width 1305 mm - Padding width 1255 mm -

Fabric Classic Grey (2-color, 100% polyester)	5040700	4190,-
Fabric Bricks T6.1 (2 colors 100% polyester)	5040742	4390,-
Fabric Double Grid T6.1 (2-color 100% polyester)	5040744	4390,-
Basaltfront panel	5040780	279,-
Basaltdrawer	5040790	549,-

Size 17: Overall width 1380 mm - Pad width 1330 mm -

Fabric Classic Grey (2-color, 100% polyester)	5040800	4290,-
Fabric Bricks T6.1 (2 colors 100% polyester)	5040842	4490,-
Fabric Double Grid T6.1 (2-color 100% polyester)	5040844	4490,-
Basaltfront panel	5040880	299,-
Basaltdrawer	5040890	549,-

Headrests with integral foam Black Series		
Surcharge for fabric covers	5070012B	136,40

Mounting material bench:

Order required material for each bench type	Carrier 1 582081 32,95	Carrier 2 582082 44,95	Carrier 3 582083 59,95	Beam 4 582084 289,-
Mounting right (size 8-14)	1x	1x		1x
Mounting left (size 8-14)	1x		1x	1x
Center mounting (size 17)	2x	1x	1x	
In addition, 1 mounting kit each	58208 89.90 is required			

Base plate 1-piece. for original Volkswagen door sill decor ship's floor

SWB: app. L 246 cm	1053812	379,-	LWB: app. L 86 cm	1053712	449,-
SWB: app. L 246 cm	1053811	519,-	LWB: app. L 286 cm	1053711	499,-

Décor Ticino

SWB: app. L 246 cm	10538120	459,-	LWB: app. L 286 cm	10537120	469,-
--------------------	----------	-------	--------------------	----------	-------

X-Trem insulator, 15 mm thickness

Needed as insulation under the base plate (2x for SWB, 3x for LWB).

Plate size 2 x 1 m.	50016	23,95
---------------------	-------	-------



Figure shows optional equipment



Seat with fabric cover Double Grid T6.1. and Isofix attachment point

Further bench seats for vehicles with plastic side trim or for right-hand drive vehicles can be found at www.reimo.com/Ausbaushop.

VARIOTECH® 3000

Movable in REIMO Grizzly rails



Grizzly" glide bar set for Variotech® 3000

2 pieces, Grizzly rails, anodized aluminum Short wheelbase length 246 cm,
1 driving position **58200 419,-**
Long wheelbase Length 286 cm, 2 driving positions* **58201 559,-**
*3 travel positions with glued slide rails (by Reimo trained specialist companies)

Grizzly" fastening set for the slide rails

Adapter for screwing the Grizzly rails to the floor assembly

Rail spacing 997 mm, short wheelbase **58202 219,-**
Rail spacing 826 mm, short wheelbase **58203 239,-**
Rail spacing 651 mm, short wheelbase **58204 219,-**

Supplementary record

For long wheelbase station wagon/van **58205 40,95**
For panel van SWB/LWB **58206 56,50**

Floor panels 3-piece, short wheelbase

	Decor ship floor		D�cor Quad		Decor Ticino	
Rail spacing	Item no	Price	Item no	Price	Item no	Price
① 651 mm	1053822	439,-	1053821	519,-	10538220	439,-
② 826 mm	1053832	439,-	1053831	519,-	10538320	439,-
③ 997 mm	1053842	439,-	1053841	519,-	10538420	439,-

Floor panels 3-piece, long wheelbase

	Decor ship floor		D�cor Quad		Decor Ticino	
Rail spacing	Item no	Price	Item no	Price	Item no	Price
① 651 mm	1053722	469,-	1053721	529,-	10537220	469,-
② 826 mm	1053732	469,-	1053731	529,-	10537320	469,-
③ 997 mm	1053742	469,-	1053741	529,-	10537420	469,-

X-Trem isolator, 18 mm. Required for short wheelbase 2 plates and for long wheelbase 3 plates. **50009 29,20**

Hint: There are two options for mounting the seat rails: Rail bolting (1 seat position in the SWB, 2 seat positions in the LWB) or the special bonding procedure, which can only be carried out in companies equipped for this purpose. This allows for driving positions as well as additional individual seats. A separate rail is required, as well as other mounting materials. There are 6 possible rail positions. The benches listed here are designed to be mounted on the right (sizes 8, 10 & 14, or size 17 center) in the empty station wagon. If there is heat exchanger in the rear, for positioning on the left in the vehicle and other upholstery combinations, a different article number is required in each case (specialist trade information folder).

For Volkswagen Transporter 6.1/6/5

- For vehicles without side plastic trim
- 3 persons sleeping/seating bench sliding and removable for empty left-hand drive vehicle without side paneling
- Ready upholstered for 3 seats
- 3 integrated retractable headrests and 3 seat belts
- Isofix attachment points for a maximum of 2 child seats (middle seat cannot be used when a child seat is used)

① Size 8: Total width 1155 mm - Pad width 1105 mm

Sleeping surface app. 205x120 cm - Rail distance 651 mm

Fabric Classic Gray (2 colors, 100% polyester)	5040400	4290,-
Fabric Bricks T6.1 (2 colors 100% polyester)	5040442	4490,-
Fabric Double Grid T6.1 (2 colors 100% polyester)	5040444	4490,-
Fabric Place T5 (2-color 100% polyester)	5040426	4490,-
Fabric Tasamo T5 (2-color 100% polyester)	5040408	4490,-
Fabric Austin T5 (2-tone 100% polyester)	5040424	4490,-
Front panel mounted decor basalt	5040480	249,-
Drawer mounted, decor basalt	5040490	679,-

① Size 10: total width 1205 mm - cushion width 1155 mm - sleeping surface app. 205x126 cm - Rail distance 651 mm.

Fabric Classic Gray (2-tone, 100% polyester)	5040000	4340,-
Fabric Bricks T6.1 (2-color, 100% polyester)	5040042	4540,-
Fabric Double Grid T6.1 (2-color, 100% polyester)	5040044	4540,-
Front panel mounted, decor basalt	5040080	249,-
Drawer mounted, decor basalt	5040090	679,-

CityVan

② Size 14: total width 1305 mm - cushion width 1255 mm - sleeping surface app. 205x136 cm - Rail distance 826 mm.

Fabric Classic (2-color, 100% polyester)	5040100	4890,-
Fabric Bricks T6.1 (2-color, 100% polyester)	5040142	5090,-
Fabric Double Grid T6.1 (2-color, 100% polyester)	5040144	5090,-
Front panel mounted, decor basalt	5040180	249,-
Drawer mounted, decor basalt	5040190	679,-

Weekender Plus

② Size 14: total width 1305 mm - cushion width 1255 mm - sleeping surface app. 205x136 cm - Rail distance 826 mm.

Fabric Classic (2-color, 100% polyester)	5040200	4890,-
Fabric Bricks T6.1 (2-color, 100% polyester)	5040242	5090,-
Fabric Double Grid T6.1 (2-color, 100% polyester)	5040244	5090,-
Front panel mounted, decor basalt	5040280	249,-
Drawer mounted, decor basalt	5040190	679,-

Weekender for the whole width of vehicle, center adjusted

③ size 17: total width 1380 mm - cushion width 1330 mm - sleeping surface app. 205x136 cm - rail spacing 997 mm.

Fabric Classic (2-color, 100% polyester)	5040300	4990,-
Fabric Bricks T6.1 (2-color, 100% polyester)	5040342	5190,-
Fabric Double Grid T6.1 (2-color, 100% polyester)	5040344	5190,-
Front panel mounted, decor basalt	5040380	249,-
Drawer mounted, decor basalt	5040390	679,-

Swivel table support stainless steel mounted on front panel (without table top) **571300M 317,90**

Further bench seats for vehicles with plastic side trim or for right-hand drive vehicles can be found at www.reimo.com/Ausbaushop.

VARIOTECH® 3000

Movable in REIMO Grizzly rails

For Mercedes-Benz Vito long

- For vehicles without side plastic trim
- 3 persons Sleeping/seating bench slidable and removable for empty vehicle without side panel
- Ready upholstered for 3 seats
- 3 integrated retractable headrests and 3 seat belts
- Isofix attachment points for a maximum of 2 child seats (middle seat cannot be used when a child seat is used)

Size 8: total width 1155 mm - cushion width 1105 mm - sleeping surface ca. 195x126 cm -Rail distance 700 mm.

Fabric Classic Gray (2-tone, 100% polyester)	5045000	4390,-
Fabric Mercedes Caluma (2-color, 100% polyester)	5045060	4590,-
Fabric Mercedes Tunja (2-color, 100% Polyester)	5045050	4590,-
Front panel mounted, decor basalt	5045080	249,-
Drawer mounted, decor basalt	5045090	679,-

Size 14: total width 1305 mm - cushion width 1255 mm - sleeping surface app. 205x136 cm - Rail distance 1050 mm.

Fabric Classic Gray (2-tone, 100% polyester)	5045200	4540,-
Fabric Mercedes Caluma (2-color, 100% Polyester)	5045260	4740,-
Fabric Mercedes Tunja (2-color, 100% polyester)	5045250	4740,-
Front panel mounted, decor basalt	5045280	249,-
Drawer mounted, decor basalt	5045290	679,-

Size 17: center adjustable: total width 1380 mm - pad width 1330 mm - sleeping surface approx. 205x136 cm rail distance 1050 mm.

Fabric Classic (2-color, 100% polyester)	5045100	4590,-
Fabric Mercedes Caluma (2-color, 100% Polyester)	5045160	4790,-
Fabric Mercedes Tunja (2-color, 100% Polyester)	5045150	4790,-
Front panel mounted, decor basalt	5045180	249,-
Drawer mounted, decor basalt	5045190	679,-

Swivel table support stainless steel mounted on front panel / drawer (without table top) **571300M 317,90**

Grizzly" glide bar set for Variotech® 3000

2 pieces, Grizzly rails, anodized aluminum
Vito long, length 2540 mm, 4 driving positions **58326 529,-**

Fastening set "Grizzly" for the slide rails

Adapter for screwing the Grizzly rails to the floor assembly Rail spacing 700 mm, Vito long **58328 339,90**
Rail spacing 1050 mm, Vito long **583282 185,90**

NEW: Cover profile for "Grizzly" slide rail

2 m length, plastic, black, ribbed **58188 25,99**

Floor adaptation steel

for rail spacing 700 mm: Order outer rail 1 pc **58327 239,-**
Order inner rail 1 pc **583271 289,-**
for rail distance 1050 mm: order 2 pieces, price per piece **58327 239,-**

Floor panels 3-piece, Vito long

Rail spacing	Decor ship floor		Décor Quad		Decor Ticino	
	Item no	Price	Item no	Price	Item no	Price
700 mm	16807	449,-	16808	469,-	168070	435,-
1050 mm	168071	449,-	168081	469,-	1680710	449,-

X-Tremisolator 18 mm. Need 3 plates for Vito long. **50009 29,20**



Attention: New decor bottom plate, picture not binding.



Hint: The Vito with existing seat mounting threads in the vehicle floor is required as the base for the rail mounting. Adapter plates are screwed and glued to these, to which the rails are attached. If the threads are not available, the rails can be mounted using a special bonding process by a company equipped for this purpose. In the rear area is always provided underbody reinforcement. The rails allow 4 driving positions as well as additional individual seats in the front area (depending on the distance to the furniture line).

Further bench seats for vehicles with plastic side trim or for right-hand drive vehicles can be found at www.reimo.com/Ausbaushop.

VARIOTECH® 3000

Movable in REIMO Grizzly rails



Note: The rails are bolted and additionally bonded with Sikaflex and the vehicle floor is reinforced with underbody beams. Peculiarity is that there are two rails different in the attachment, one for the outside and another for the inside.

The rails allow 3 driving positions as well as 1-2 additional individual seats in the front area, depending on the distance to the furniture line. There are 4 possible rail positions in vehicle, benches sizes 8 & 10 listed here are for mounting on right, bench size 17 is for mounting in center of empty station wagon. If there is a heat exchanger in rear, for positioning on left in the vehicle and other upholstery combinations, a different article number is required in each case (specialist trade info folder).

For Renault Trafic, Fiat Talento from YOC. 8/2014/
Opel Vivaro B until YOC. 3/2019

- For vehicles without side plastic trim
- 3 persons Sleeping/seating bench sliding and removable for empty left-hand drive vehicle without side paneling
- Ready upholstered for 3 seats
- 3 integrated retractable headrests and 3 seat belts
- Isofix attachment points for a maximum of 2 child seats (middle seat cannot be used when a child seat is used)

Size 8: Total width 1130 mm - Pad width 1080 mm - Rail spacing 673 mm.

Fabric Compo (2-color, 100% polyester)	5044150	4590,-
Fabric Classic Gray (2-color, 100% Polyester)	5044400	4390,-
Fabric Black Patterned (2-color, 100% polyester)	5044140	4590,-
Front panel mounted, decor basalt	5044180	249,-
Drawer mounted, decor basalt	5044190	679,-

Size 10: total width 1205 mm - pad width 1155 mm - rail spacing 673 mm.

Fabric Compo (2-color, 100% polyester)	5044050	4640,-
Fabric Classic Gray (2-color, 100% polyester)	5044000	4440,-
Fabric Black Patterned (2-color, 100% Polyester)	5044040	4640,-
Front panel mounted, decor basalt	5044080	249,-
Drawer mounted, decor basalt	5044090	679,-

Grizzly" glide bar set for Variotech 3000® -Renault Trafic
2 pieces, Grizzly rails, anodized aluminum, 3 driving positions

SWB, length 2490 mm, rail spacing 673 mm	58128	499,-
LWB, length 2890 mm, distance between rails 673 mm	581285	629,-

Size 17, center adjusted: Total width 1380 mm - Pad width 1330 mm - Rail spacing 1020 mm.

Fabric Compo (2-color, 100% polyester)	5044350	4590,-
Fabric Classic (2-color, 100% polyester)	5044300	4390,-
Fabric Black Patterned (2-color, 100% polyester)	5044340	4590,-
Front panel mounted, decor basalt	5044380	249,-
Drawer mounted, decor basalt	5044390	679,-

Grizzly" glide bar set for Variotech 3000® -Renault Trafic
2 pieces, Grizzly rails, anodized aluminum

SWB, length 2490 mm, rail distance 1020 mm	581280	499,-
LWB, length 2890 mm, rail spacing 1020 mm	581288	629,-

Swivel table support stainless steel
mounted on front panel (without table top) 571300M 317,90

Grizzly" fastening set for the slide rails
Adapter for screwing the Grizzly rails to the floor assembly

Rail spacing 673 mm, Kombi SWB/LWB	58133	218,90
Rail spacing 1020 mm, SWB/LWB combination	58135	244,-

Floor reinforcement steel

for rail spacing 673 mm 1x floor reinforcement front	581251	229,-
1x rear shelf support	581252A	389,90

	Decor ship floor		Décor Quad		Decor Ticino	
Wheelbase	Item no	Price	Item no	Price	Item no	Price
briefly	141142	459,-	141144	459,-	1411420	459,-
long	141143	459,-	1411441	459,-	1411430	459,-

Base plate 3-part, rail spacing 673 mm

	Decor ship floor		Décor Quad		Decor Ticino	
Wheelbase	Item no	Price	Item no	Price	Item no	Price
briefly	141146	459,-	141147	459,-	1411460	459,-
long	141148	459,-	141149	509,-	1411480	459,-

Base plate 3-part, rail spacing 1020 mm X-Tremisolator

18 mm. Required for short wheelbase 2 plates and for long wheelbase 3 plates.	50009	29,20
---	-------	-------

Further bench seats for vehicles with plastic side trim or for right-hand drive vehicles can be found at www.reimo.com/Ausbaushop.

VARIOTECH® 3000

Movable in REIMO Grizzly rails

For Ford Transit Custom from YOC. 8/2013

- For vehicles without side plastic trim
- 3 persons Sleeping/seating bench sliding and removable for empty left-hand drive vehicle without side paneling
- Ready upholstered for 3 seats
- 3 integrated retractable headrests and 3 seat belts
- Isofix attachment points for a maximum of 2 child seats (middle seat cannot be used when a child seat is used)

Size 8: total width 1155 mm - pad width 1105 mm - rail spacing 766 mm.

Fabric Classic Gray (2-tone, 100% polyester)	5042100	4290,-
Front panel mounted, decor basalt	5042180	249,-
Drawer mounted, decor basalt	5042190	679,-

Size 10: total width 1205 mm - pad width 1155 mm - rail spacing 766 mm.

Fabric Classic Gray (2-tone, 100% polyester)	5042000	4440,-
Front panel mounted, decor basalt	5042080	249,-
Drawer mounted, decor basalt	5042090	679,-

Swivel table support stainless steel front panel mounted (without table top)	571300M	317,90
--	---------	--------

Grizzly" glide bar set for Variotech® 3000 2 pieces, Grizzly rails, anodized aluminum, single seat possible. Length 2490 mm, 3 travel positions	581960	569,-
--	--------	-------

Grizzly" fastening set for the slide rails for screwing plus bonding with Sikaflex (not included in delivery). Consists of: 2 floor adapters, underfloor reinforcements, screw set rail spacing 766 mm, combi SWB	58193	515,90
---	-------	--------

Base plate 3-part, rail spacing 766 mm

X-Tremisolator 18 mm. 3 plates are required.	50009	29,20
--	-------	-------

	Decor ship floor		Decor Ticino	
Wheelbase	Item no	Price	Item no	Price
briefly	105230	419,-	1052300	449,-



Bed extension not included, to be ordered on request.



Note: As a basis for the rail fastening, the version of the combi with existing seat fastening threads is required. The rails are bolted and bonded with Sikaflex, additional reinforcements are installed underfloor. There is only one rail constellation with the rail spacing of 766 mm symmetrical.



V 3000 Seat bench
for Transit Custom /
Tourneo Custom V710
Available Q1 2024



All info about
product



Decor ship floor



Decor Ticino

Further bench seats for vehicles with plastic side trim or for right-hand drive vehicles can be found at www.reimo.com/Ausbaushop.



Scan the QR code to see the video of
Variotech 3000.

SAFETY BELTS

2-point lap belt and 3-point safety belts

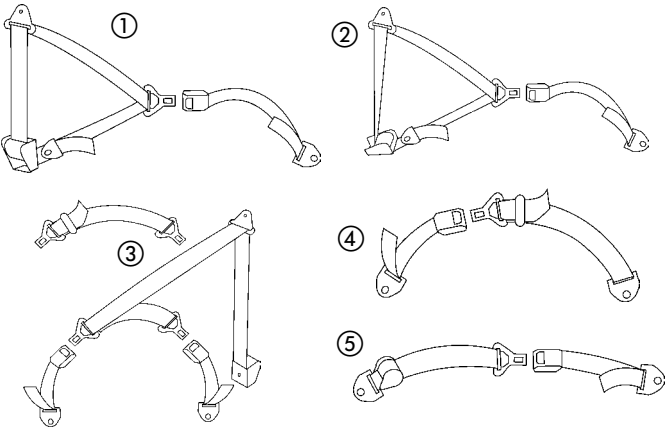

- ① **3-point automatic safety belt, universal use.**
belt length 4 m, can be shortened.
Lock belt adjustable from approx. 35 - 60 cm.
Incl. Mounting screws and small parts **58151 60,60**
- ② **3-point automatic safety belt for Variotech benches 3000 Automatic belt, if the belt roller must be mounted vertically.**
Belt length 4 m, lock belt app. 20 cm. Incl. Mounting screws and small parts **58118 55,-**
- ③ **3-point Special safety belt. If a row of furniture is mounted between the upper belt point and the seat.**
Belt length 3.6 m. 2 belt whips adjustable in length, approx. 30 - 60 cm. Incl. longitudinally adjustable lap belt adapter. Necessary if the 3-point belt cannot be used in a driving position. Incl. Mounting screws and small parts **58150 92,90**
As ③, but with belt roller to be mounted horizontally for retrofitting the 3rd belt. Safety belt e.g. family benches T5 **58149 104,50**
- ④ **Lap belt overlong for the middle seat with passenger car registration, for vehicles with first registration before 2005; or for motorhome registration, 2 x per bench (outer seats), if no 3-point belts can be used on the outside (e.g. in panel vans).** Belt length 150 cm with adjustable lock belt from 30 - 60 cm **58152 29,90**
- ⑤ **Automatic pool belt with adjustable lock belt**
Belt length 150 cm, lock belt from 30 - 60 cm **58153 46,90**

Accessories seat belts

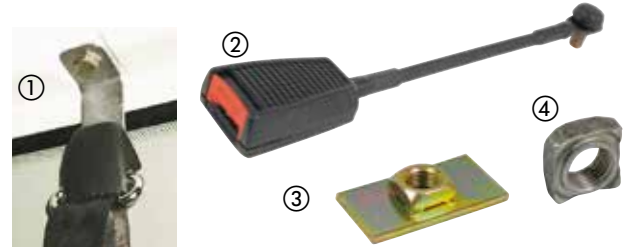

- ① **Seat belt suspension** For mounting the seat belt centrally above the rear window. Standard, cranked for VW T4 **58050 18,99**
straight, VW T5 **58051 18,99**
- ② **Belt whip for Volkswagen Transporter 4 S-seats** (driver or passenger side) required for retrofitting swivel consoles in the VW T4. Length: 310 mm **58046 27,90**
- ③ **Threaded plate 60 x 30 mm**, to weld threads for seat belts at points provided by the vehicle manufacturer. **58052 6,90**
- ④ **Weld-in nut with fine thread** **58045 3,50**

Seat belt adaptations for Volkswagen Transporter 5 from YOC. 3/06

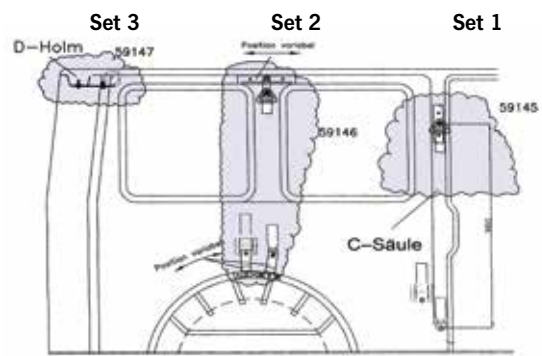

- For 3-point harness
 - For retrofitting the belt anchorage points on the VW T5 panel van
 - Suitable for short and long wheelbase
 - Delivery without straps, suitable for 1 side
- Set 1:** on the C-pillar left or right **59145 39,70**
Set 2: above the rear wheel arch left. or. r. **59146 218,-**
Set 3: at the D-bar at the top in connection with the belt **59147 71,90**
3 point harness 58149 104,50





Aguti S2 sleep bench with integrated headrest G2000

- Angle ergonomically adjusted in sitting position
- Integrated seat belts per seat
- High quality molded foams with lateral support incl. Isofix holder
- Individually adjustable backrest
- Adaptation to original Vito/V-Class/PSA rail systems by means of adapter (optionally available)
- The entire bench can be moved in the rails or is completely removable
- Each seat can be folded down individually
- In the folded state, the lying surface is completely flat
- The belt buckles dive under the lying surface

Seat integrated into seat belt, which can be converted into a sleeping bench by simply folding the back.

Bench which can be converted into a sleeping bench in just a few steps. **Lying surface:** Length 1.86 m incl. leg rest, without leg rest length 1.26 m, width per seat 0.5 m

Color seat covers anthracite patterned

59656

2790,-



Aguti adapter for sleep bench S2

Suitable for original PSA rail system

59658 672,-

Suitable for original Mercedes rail system

59659 534,-

Aguti leg rest for sleep bench S2

Covered right and left. **Dimensions:** (L x W) 60 cm x 50 cm

2 piece

59657

879,-



SITTING / SLEEPING BENCHES



Motorhome homologation
acc. to StVZO 76/115/ECE
acc. to manufacturer

Bench Divan 502 can also be used against direction of travel

Bench Divan 502 - cozy bench

Comfortable bench for 2 people. Bench width about 90 cm. Can also be mounted against the direction of travel. The inclination of the backrest is adjustable.

Please note the installation in vehicles must be approved by the TÜV. We therefore recommend that you consult your responsible TÜV office before installation.

Suitable for Sprinter, LT, Ducato, Renault and other vehicles.

Mounting of two lap belts possible.

Scope of delivery: Pre-assembled bench with foam and covers, ready upholstered.

Technical info Divan Bench: The Divan Bench 502 is without seat belts and designed for the front position against the direction of travel. Equipment: High quality foam with great density. High quality Upholstery fabric. Sturdy tubular steel frame.

Add. storage space under seat. The installation can be done on a base plate or directly on the vehicle floor (with or without rubber mat). Seat width app. 96 cm, seat height approx. 52 cm. Total height about 125 cm, total depth about 90 cm. Sleeping surface app. 96 x 194 cm. Widening (approx. 30 cm) possible. Plinth height about 21 cm can be used as storage space.

Control lever backrest right

59232 1654,-

Control lever backrest left (useful for bench installation against direction of travel)

59234 1654,-

Wood trim, anthracite for seat frame

59221 164,90



Motorhome homologation
acc. to StVZO 76/115/ECE
acc. to manufacturer

Bench Divano 506 can also be used against direction of travel

Divano 506 bench

Divano bench 506 is equipped with seat belt tether and 2 three-point automatic seat belts. Shifting forward and sideways possible. (lateral displacement 27 cm, forward 17 cm)

Equipment: High quality high density foam. High quality upholstery cover fabric. sturdy tubular steel frame.

Dims.: seat width app. 90 cm, seat height app. 48 cm. Total height approx. 129 cm, total depth approx. 63 cm. Widening (approx. 27 cm) possible.

Plinth height about 20 cm, can be used as storage space.

Scope of delivery: Pre-assembled bench with foam and covers, ready upholstered.

With shifting device to the front and to the side.

Divano 506 with belt support and 2 three-point safety belts.

Operating lever right

59236 2569,-

Control lever left (useful for bench installation against direction of travel)

592361 2569,-



Motorhome homologation
acc. to StVZO 76/115/ECE
acc. to manufacturer

SK7 bench seat system- Extend your sleeping space into the cab

The solution when you want to make full use of space.

Turn the driver or passenger seat, fold out SK 7 bench and you have a comfortable bed with 190 cm length. During the day it is a comfortable seat for 2 people with 2 integrated three-point seat belts. Sleeping surface can be widened to 120 cm by means of a transverse sliding device & additional upholstery. Adjustable tilt of seat and backrest for customized seating comfort.

Suitable for Sprinter, LT, Ducato, Renault and other vehicles.

Fixed bench seat with 2 integrated three-point belts attached to a rigid belt column.

Bed is formed from 1 bench, With transverse sliding device for bed widening up to 1.20 m. TÜV confirmation for motorhome approval is supplied by the manufacturer.

Technical info SK 7: Inst. in vehicle on base plate (w/ or without insulation). If base plate is insulated, it must be underlaid with wood in the area of the belt crossbar.

Dims.: seat width 950 mm, seat height app. 590 mm. Total height app. 1250 mm.

Total depth app. 900 mm. Sleeping surface app. 960 x 1880 mm. Widening by approx. 200 mm possible. Plinth height app. 210 mm (can be used as storage space).

Scope of delivery: Pre-assembled bench on mounting bracket, ready padded with foam and covers, incl. 2 three-point belts. With transverse sliding device for bed widening up to 1200 mm (w/o. additional padding). Cushion gray

 Left-hand drive

59240 3439,-

 righthanddrive

59225 3150,-

Additional cushion for SK7 bench system (59240) to cover the Bed widening

59241 312,-

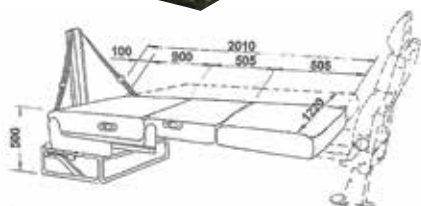

SITTING / SLEEPING BENCHES



① Rotating double bench

With integrated 3-point safety belt for the middle seat. Adjustable backrest. Belt tensioner right, suitable for Ducato X250 airbag system. Rotating fitting. Isofix anchorage for the middle seat. M1-approved acc. to CE regulations R14 & R17 for installation in DUCATO X250 cab
Model 650, Cover Black/Grey **59252 3362,-**

② Rotating single seat

Adjustable backrest. Belt tensioner suitable for Ducato X250 airbag system. Swivel console and seat tilt adjustment. M1-approved acc. to CE regulations R14 & R17 for installation in DUCATO X250 cab.
Model 610, Cover Black/Grey **59254 1888,-**



Seat/sleeper bench

Upholstery folds down to form a couch. Bed size: 1870 mm x 1000 mm. A side armrest. Adjustment of the backrest by means of sliding rails transverse rail (lateral shift) to widen the bed. Motorhome homologation acc. to StVZO 76/115/EC as per manufacturer, status 2005/41/EC

Seat-sleeper bench
with integrated 3-point safety belts **59242 4650,-**



Euroseat A400 - TÜV approved, with integrated three-point belt for Variotech 3000

Fabric Renault Traffic Black Patterned/Black:
 Seatbelt buckle right **59363 1349,-**
 Belt buckle left side **59364 1399,-**

Fabric Mercedes Tunja/Black:
 Seat belt buckle right **593626 1399,-**
 Belt buckle left side **593627 1399,-**

Fabric Classic Gray / Black: Belt buckle right **59371 1199,-**
 Belt buckle left, **59372 1199,-**

Base/adaptor is required for the single seat A400. The base is required for installation of A400 seat in conjunction with REIMO Grizzly floor rail. Suitable for Renault Traffic (e.g. 581280, 58128) and Mercedes Vito (e.g. 58326) with bolted floor rail. **58194 431,-**



Installation tested for:
VW T5, VW Crafter, Mercedes-Benz Sprinter, Fiat Ducato/Jumper/Boxer, Ford Transit until 2014

Pilot seat for passenger compartment

With integrated 3-point safety belts. Different seat heights can be realized. Adjustable backrest, armrests and headrests. With M1 classification, suitable for installation in passenger car / motorhome. Meets the current standards for safety, valid from 1.11.2014 ECE14, ECE17. Design: Classic dark gray

Euro seat A 400 with 2 armrests (without seat base)
 Belt connection left **59372 1199,-**
 Belt connection right **59371 1199,-**

Seat bases in different heights
 incl. floor rail adaptation (you need 2 pieces: 1 right and 1 left pedestal per seat):

Seat base height 23 cm (seat height 41 cm)	left	59366 137,90
	right	59365 137,90
Seat base height 28 cm (seat height 46 cm)	left	59368 137,90
	right	59367 137,90
Seat base height 33 cm (seat height 51 cm)	left	59370 142,90
	right	59369 142,90

Aluminum slide rail double row for fixing one seat or several seats one behind the other.
 Per seat approx. 1 meter seat rail necessary **59379 376,-**
 Length 2,40 m
 Length 3,00 m **593791 459,-**

Special adhesive for bonding the floor rail to the body. Required are at least.
 2 cartridges per meter of rail length. Cartridge 600 ml **593795 28,95**

SINGLE SEATS / PILOT SEATS



Macaw Black/Grey

Pilot seat S 5.1

- With integrated headrest.
- With ABE.

Dims.: Height 92 cm, backrest height 82 cm, seat width with armrests 62 cm, seat depth 52 cm
Weight: app. 17 kg

S 5.1 Atlantic Blue	592053	586,-
S 5.1 Macaw Black/Grey	592055	589,-



Tavoc 2

Pilot seat S 6.1

- With height and tilt adjustable headrest
- With ABE

Dims.: Height (incl. headrest) 96-106 cm, backrest height (incl. headrest) 79-90 cm, seat width with armrests 62 cm, seat depth 52 cm
Weight: app. 18 kg

S 6.1 Tavoc 2 Grey / Black	592103	673,-
-----------------------------------	---------------	--------------



Pilot seat S 8.1

- Distinctive side guides and soft foam parts
- Backrest quick adjustment
- Height adjustable armrests
- With ABE
- With height and tilt adjustable headrest and pronounced side guides.

Dimensions: Height (incl. headrest) 94-105 cm, backrest height (incl. headrest) 79-90 cm, seat width with armrests 62 cm, seat depth 53 cm, weight: approx. 18 kg

S 8.1 Tavoc Black/Grey	592131	679,-
S 8.1 Macaw Black/Grey	592132	679,-



Atlantic blue

Pilot seat S 9.1

- Distinctive side guides and soft foam parts
- Backrest quick adjustment
- Height adjustable armrests.
- With ABE

With integrated headrest. Backrest height and headrest according to new EC standard.

Dims.: Height 92 cm, backrest height 82 cm, Seat width with armrests 62 cm, seat depth 53 cm. Weight: app. 18 kg

S 9.1 Atlantic Blue	592144	613,-
S 9.1 Tavoc 2 Grey / Black	592145	613,-
S 9.1 Macaw Black/Grey	592146	613,-

Attention:

Sportscraft seats may be used in Germany for motorhomes and passenger cars. Outside Germany, the use must be clarified with the regional TÜV. For new vehicles from season.2022 please clarify the approval regarding the seat recognition with the TÜV.



Macaw Black/Grey

Pilot seat S 10.1

- Armrests integrated into the backrest - creating a larger passageway into the living area with maximum seat width
- Quick adjustment of the backrest in segments of >2°
- With front seat tilt adjustment
- With integrated headrest

S 10.1 Tavoc 2 Grey / Black	Fs* 594054	1049,-	S 10.1 Macaw Black/Grey	Fs* 594056	1049,-
	Bfs** 594055	1049,-		Bfs** 594057	1049,-

*Fs: driver side, **Bfs: passenger side

Accessories for Sportscraft van seats

Seat heating	59165	245,-
Lumbar support	591651	35,95

Please order with new order, as not retrofittable.



Magic Comfort MSH 300 - Carbon seat heater

- Easy installation
- Super fast and adjustable heating
- 3 heat settings from 10 to 70 watts
- Cut to size carbon heating elements

Seat inserts with carbon heating for the driver's and passenger's seat, heat up quickly and provide instant warmth. Easy operation by ergonomic push button with LED display.

Input voltage (DC) 12 V, rated input power (DC) 140 W, power consumption 140.00 W, dimensions: W 270 x H 580 x D 2 mm. Weight: 1.32 kg

4 piece	59006	375,-
---------	--------------	--------------



Relax Seat System - Electrically extendable footrest

- Specially designed for panel vans to use the space in front of the passenger seat and increase comfort
- Quick assembly without disassembly of cabin seat
- Low weight

To be used only with the original cabin seats and only with the vehicle in park position. Mounts under the original seat without having to remove it.

Compatibility with produced seat of the Fiat Ducato X250 YOC. 2006 to 2019 and the Fiat Ducato X 290 My. 2014 to 2019. Certified in R14 in compatibility with CTA turntable P/N 9PG0023000V01 for Fiat Ducato.

Certified in R17 in compatibility with FIAT DUCATO / CITROEN JUMPER / PEUGEOT BOXER seats and CTA / FIAT / AGUTI and rotating plates with a maximum weight of 15 kg.

Scope of delivery: Relax Seat System with electrically extendable footrest for passenger seat, mounting kit and WI-FI remote control

59649	579,-
--------------	--------------

3-POINT BELT SUPPORT FOR DUCATO, BOXER, JUMPER

Universal belt trestles for 2 people

Tested in the vehicle (homologation) for Fiat Ducato and similar vehicles.
Tested in vehicle acc. to ECE R14.06/07.
An acceptance at TÜV acc to § 21 (individual acceptance) is necessary. Prior clarification of the mounting situation in the vehicle with the TÜV is recommended.

Belt supports are each positioned on longitudinal member of vehicle; in longitudinal direction, the position is variable. The attachment is made by means of screw connections through the vehicle floor. Weight of the belt stand without fastening parts is between 12.5 and 13.5 kg. Delivery in each case complete with mounting hardware and safety straps.

There are 3 different basic types:

- ① Type 1: For Fiat Ducato X250/X290 panel vans/station wagons:
Seatbelt kit normal 59101 615,-
Belt buck kit normal 59103 608,-
Belt support kit raised (83 mm higher) 59515 583,-
- ② Type 2: For Fiat Ducato X250/X290 chassis with high ladder frame:
Belt buck kit normal 59103 608,-
Belt support kit raised (83 mm higher) 59515 583,-
- ③ Type 3: For Fiat Ducato X250/X290 chassis with flat frame:
Belt buck kit normal 59102 597,-
Raised belt support kit (83 mm higher) 59516 574,-

Suitable accessories

- ③ Headrest Kit
Scope of delivery: 2 curved headrests including mounting plate
595008 299,-
- ④ Isofix holder
For normal belt trestles 59536 156,-
For elevated belt trestles 59531 142,-



Suitable for vehicles with registration as a special motorhome. Tested in vehicle acc. to ECE R14.06/07.

Belt buck for Ducato, Boxer, Jumper

- For retrofitting in motorhomes Fiat Ducato, Peugeot Boxer, Citroën Jumper
- With automatic 3-point harnesses (suit. for child seat)
- Belts are guided concealed in the column, no twisting possible
- Self-supporting design w/o. cross braces preserves storage space in storage box
- Tested according to applicable EC directives on rigid plate
- The existing bench will continue to be used, installation must be registered
- With expert opinion for M1 motorhomes: acceptance acc. to § 21 necessary.
- Mounting on vehicle floor: Not included in scope of delivery. (Please clarify installation with your local TÜV)

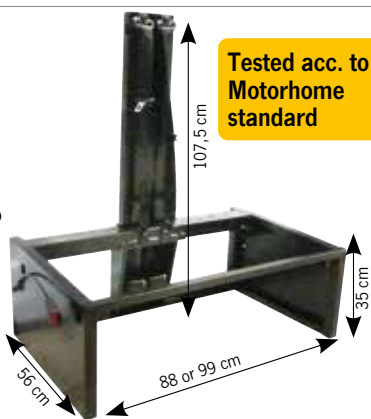

Dims.: W 99 x D 56 x H 107.5 cm, seat height without support: 35 cm, weight app. 4 kg 59560 1066,-

Dims.: W 88 x D 56 x H 107.5 cm, seat height w/o. support: 35 cm. Weight app. 40 kg 59561 1066,-

Tested acc. to Motorhome standard

Tested on the rigid plate according to regulation 76/115 status 96/38 and 2005/41. Acceptance according to § 21 (indiv. acc.).



Divano 505 base, incl. 2x 3 point safety belt

For floor fixing, 5 pieces of hexagon bolts M12 UNI5739 are recommended. Seat height without support: 21 cm, weight app. 28.6 kg

592360 770,-

Universal double bench

- Fully tested according to ECE requirements for M1 and N1 vehicles
- Double bench with comfortable single seats
- Integrated 3-point safety belts
- Side adjustment for additional clearance of 110 mm during the ride
- Longitudinal adjustment & adjustable backrest for more passenger comfort
- Two piece frame with storage space
- ISOFIX anchorages
- Lower base for vehicles without double bottom

For vehicles without double bottom. The individually adjustable seats are mounted on guides that allow both lateral and longitudinal adjustment for greater comfort while driving. The seat belts are integrated into the backrests. The product is fully tested according to ECE requirements for M1 and N1 vehicles. Armrest optionally available.

Double bench 59258 3099,-
Armrest 59259 159,90



3-POINT BELT BUCK



Picture shows universal belt buck 595010 with pad 595005 in Fiat Ducato

General operating permit (ABE)

An ABE is an approval that usually accompanies particularly easy to assemble parts. The assumption is that the buyer himself can not do much wrong when attaching these parts (mostly, for example, rims, etc). Therefore, after performing modification on vehicle with this part, no further action is necessary. The vehicle operating license remains intact and the vehicle can continue to be used.

However, it must be ensured that all instructions and requirements from the ABE are complied with. The ABE papers must be carried at all times during each ride. If desired, the information from the ABE can often also be entered in the vehicle documents so that the ABE no longer has to be carried separately.

TÜV parts certificate A TÜV parts certificate is the most common form of approval for tuning parts. Parts certificate contains precise instructions & conditions. In order to avoid incorrect installation of tuning parts or incorrect modifications, the vehicle must be presented to a TÜV inspector after the conversion. Here, not only the conformity of the certificate with the associated part and also the corresponding vehicle type / model is checked, but also the quality of the conversion.

Vehicle operating permit expires temporarily directly after conversion until conversion has been "registered". Only the direct route to the TÜV test center may still be undertaken with the vehicle.

The TÜV inspector issues a certificate - a registration according to StVZO §19.3. With this certificate, the modification can then be entered in the vehicle documents at the registration office. For motor vehicles that had initial registration before 1.1.1992, there are no special requirements for modifications to seat console or seat rails.

In addition, safety belts were not yet required for motor homes first registered before Jan. 1, 1992. Therefore, no testing is mandatory for the installation of rotary bases in these older vehicles. From first registration on 1.1.1992, at least 1 cert. acc. to 76/115 EWG (Europe-wide ECE R14) must be avail. when changing seat structure for app. according to STVZO.

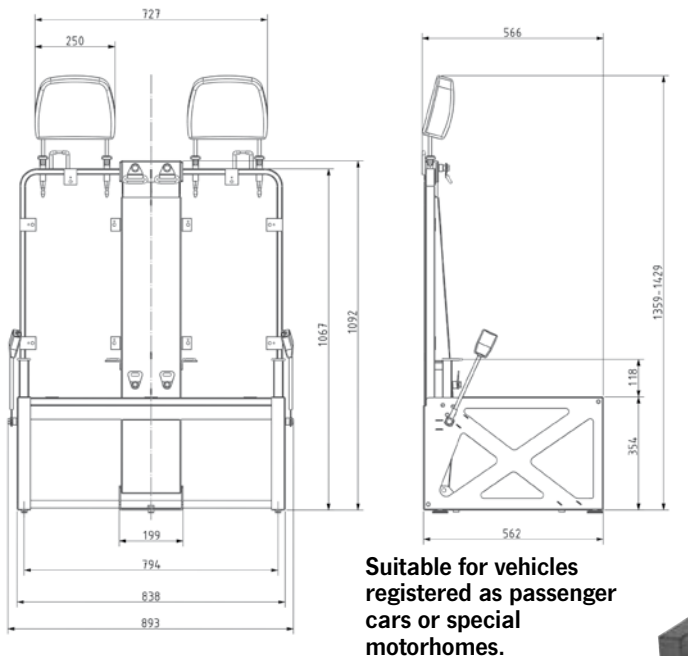

Suitable for vehicles registered as passenger cars or special motorhomes.

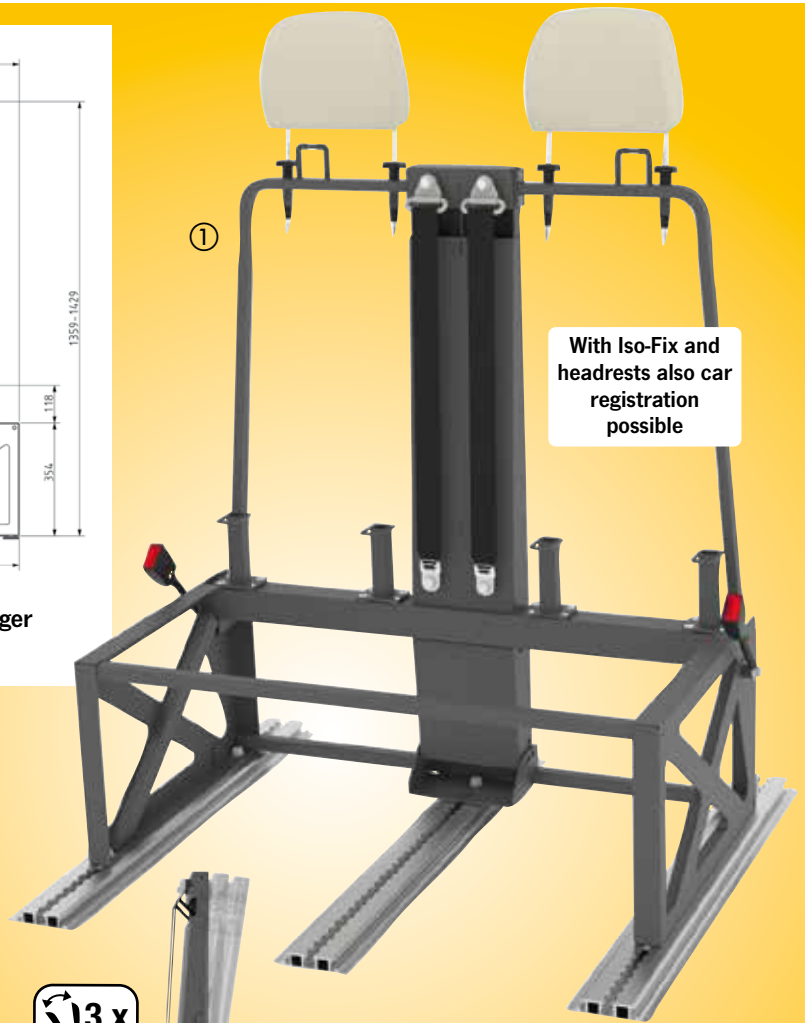

Universal belt buck for flex. installation

Modular belt trestle for 2 persons with integrated three-point belts and Isofix child seat mounts, expandable with tested headrests.

For better seating comfort, the backrest can be mounted at a slight angle. An optional elevation kit is available for vehicles with a height jump to the cab or platform.

The belt buck is installed in the vehicle by means of three aluminum rails and can therefore be easily removed again if necessary. The aluminum rails are glued to the vehicle floor and additionally screwed in the rear area.

A test certificate according to ECE R14.07 (seat belt anchorages), ECE R17 (seat strength) and ECE R16 is enclosed.

It documents the test in the Ford Transit and refers to the fact that the tests can be transferred to other vehicles. ("the results are representative also for other types of vehicles").

We recommend prior clarification of installation situation with responsible TÜV.

① 3-point belt support 900 mm, steel, with adjustable backrest in 3 positions

Scope of delivery: Belt buck, 2 three-point belts, Isofix brackets, backrest with bracket for headrests
595010 1199,-

② Increase kit for additional 120 mm height
595002 114,-

③ Seat cushion, scope of delivery with cover & two headrests
595005 569,-

Installation kit consisting of:

3x aluminum profiles length 1250 mm each, fastening material for profiles, adhesive
595006 434,-

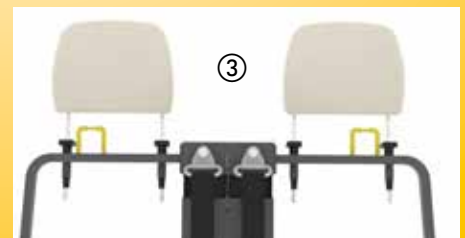
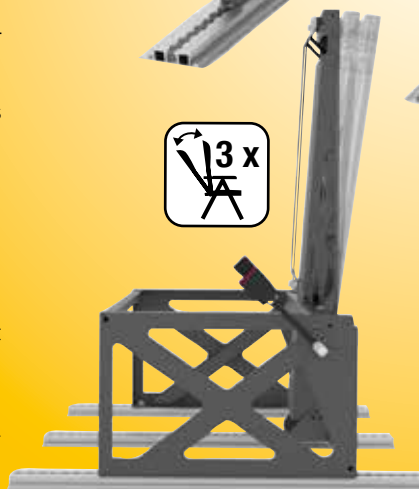

SWIVEL CONSOLES for Volkswagen Transporter 6.1/6/5

For original seats VWT6.1/T6/T5 (single seats) from 2003 onwards

Driver's side	595717	266,-
Passenger side	595723	278,-
Handbrake adapter without leatherette cuff	595718	43,65

Without TÜV (35 mm height)

With TÜV (25,5 mm height)

For original seat FS/BFS from YOC. 2003
If original battery is installed.

	59502	263,-
--	-------	-------

Matching Handbrake lowering
necessary for driver's side swivel console

LHD	59616	38,20
RHD	596160	38,20

Swivel bracket from YOC. 2003
Installation only if there is no battery under seat. Driver's side incl. handbrake lowering.

Driver's side	59498	279,-
Passenger side	59499	257,-

Matching handbrake lowering
necessary for driver's side swivel console

	59616	38,20
--	-------	-------

WVT5 for original double seat YOC. 2003-2015
Test number: 76/115/EEC. Dims. in mm: L 605 x B 406 x H 229 (without screws)

NEW! LHD	594962	584,-
RHD	594961	555,-

Without TÜV

With TÜV

WVT6.1/T6/T5 for original double seat bench from YOC. 2003-2015
With parts certificate. Without cable gland.

LHD	59496	639,-
-----	-------	-------

WVT6.1/T6/T5 for original double seat from YOC. 2003
With parts certificate. Without cable gland.

LHD	59667	639,-
-----	-------	-------

NEW

With TÜV

Seat base for Original seat from 2003
Height adjustable: 230 - 360 mm, Passenger side

	596501	814,-
--	--------	-------

Without TÜV

For original seat from YOC. 2003 With Safe
Driver side/passenger side

	59647	489,-
--	-------	-------

Without TÜV

Adapter Sportcraft seat from YOC. 2003
Incl. Slide rails For mounting Sportcraft seats on original or swivel brackets.

	596451	328,-
--	--------	-------

Without TÜV (42 mm height)

For original seat FS/BFS from YOC. 2003

	59699	165,-
Adapter handbrake	59697	41,90

With TÜV

Rotating base for WVT6.1/T6/T5 driver+passenger side w/ ABE
Mounting also possible on vehicles with battery in seat box. For driver's side, pls. also order handbrake adapter 59616.

	59653	268,-
--	-------	-------

Matching handbrake lowering
necessary for driver's side swivel console

	59616	38,20
--	-------	-------

With TÜV

Swivel console for original seat from YOC. 2003

- No increase in seat height
- Rotation of the seat possible even with the door closed

With mounting material incl. handbrake-lever adapter. TÜV tested with parts certificate.

Locking possible in direction of travel or also in 180° position. Handbrake lever individually mountable. External dim.: 430 x 430 x 210 mm. Weight app. 17 kg.

Driver's side	59593	319,-
Passenger side	59594	299,-

With TÜV

Swivel console for WVT6.1/T6/T5
For battery inst. Height 250 mm

Driver side	59538	539,-
Passenger side	59544	499,-

With TÜV



SWIVEL CONSOLES for Volkswagen/Citroën/Renault/Toyota/Opel

For VW T4

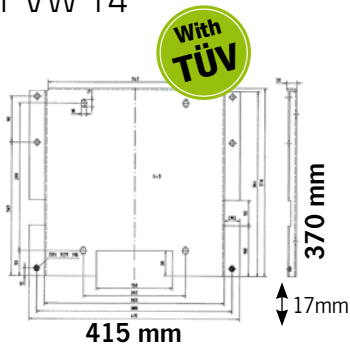

Adapter for Sportscraft seat to swivel base 59501.
Original rails required.
59510 192,-



Swivel console for original seat YOC. 1996-2003
Driver's side 59471 192,-
Passenger side 594711 192,-



Swivel console original seat + Sportscraft for year 1996-2003
Rotating in middle, mw/ cable gland
Driver's side/passenger's side.
59501 286,-

For VW T4 until 1996



Rotating console up to YOC.
Center rotating for driver/passengerside. Belt whip (No. E5487) must be ordered as well.
59511 301,-

Belt whip for swivel bracket 59511
Screw connection to seat box.
E5487 51,40

For VW T3 YOC. 1979-1992



Swivel base for original seat For T3 first registration before 1.1.1992 no TÜV necessary, from 1.1.1992 at least a certificate acc. to 76/115 EWG (Europe-wide ECE R14) must be avail..
59500 303,-

Adapter f. Sportscraft seat For T3 first registration before 1.1.1992 no TÜV nec., from 1.1.1992 at least a certificate acc. to 76/115 EWG (Europe-wide ECE R14) must be avail.
59503 154,-

For Citroën Jumpy / Peugeot Expert as of 2016



Swivel bracket for original seat
Driver's side 595881 489,-
Passenger side 595882 419,-
Handbrake cover 595889 18,50

Swivel console for original seat
Driver's side 595883 368,-
Passenger side 595884 372,-
Handbrake lever adapter 595885 46,50

Swivel consoles tested in conjunction with the electrically adjustable seats of:

- Toyota Proace/Proace Verso,
- Citroën Jumpy/SpaceTourer,
- Peugeot Expert/Traveller,
- Opel Vivaro/Zafira Live

Low construction
Large cable gland
Low weight (approx. 9.4 kg)
Assembly friendly
Tested acc. to M1/N1



Driver's side 59008 328,-
Passenger side 59009 328,-
Handbrake lowering 59010 65,25

For Citroën Spacetourer, Jumpy/Peugeot Expert, Traveller/ Toyota ProAce II as of 2016/ Opel Vivaro as of 2019



Swivel bracket flat for original seat
Driver's side 59668 349,90
Passenger side 59669 360,-
Handbrake cover 596681 45,90



Swivel console w/ elevation for original seat
Driver's side 59670 499,-
Passenger side 59671 419,-
Handbrake cover 596701 89,90

SWIVEL CONSOLES for Ford/ Renault/ Opel/ Fiat/ Nissan

For Ford Transit/
Tourneo Custom

With TÜV



Swivel bracket V362

Driver's side **59587** 311,-
Passenger side **595870** 311,-



Handbrake lowering V362
for driver side
595871 32,60

For Ford Transit

With TÜV



Fig. shows swivel console
for driver's side

Swivel console for mounting between original
seat box and Ford slide rails, YOC. 2004 - 2012
(Only for vehicles with handbrake left)

Driver's side **59529** 325,-
Passenger side **595291** 325,-

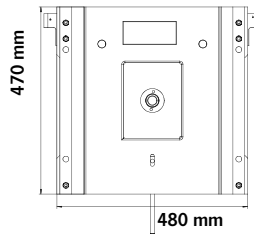

For original seat
Ford Transit Custom
& Tourneo from 2012,
Ford Transit
from YOC. 2014

With TÜV



Driver's side **595711** 267,-
Passenger side **595710** 267,-

For original seat
Ford Transit Custom &
Tourneo from 2012
Ford Transit from YOC. 2014

NEW

With TÜV



Swivel bracket
Driver side + passenger side
59672 256,-

Handbrake adapter Tourneo u.
Custom incl. leatherette cuff **596722** 69,90
Turntable elevation kit Tourneo &
Custom from 2012 **596721** 49,95

For Renault Trafic from 2014/
Fiat Talento 2016-2020/
Nissan NV 300 from 2016/
Opel Vivaro 2014-2019

NEW

With TÜV



Swivel console for Renault Trafic from 2014
Driver side **59673** 256,-
Passenger side **59674** 256,-

For Renault Trafic II / Opel Vivaro A
YOC. 2001 until 2014

With TÜV

With TÜV



For double seat
594960 704,-



For original seat
Driver's side **59570** 279,-
Passenger side **595701** 279,-

For Renault Trafic X82, Trafic III /
Opel Vivaro B from YOC. 2014
and Fiat Talento

With TÜV

With TÜV



For original seat
Driver's side **59585** 339,-
Passenger side **59586** 312,-

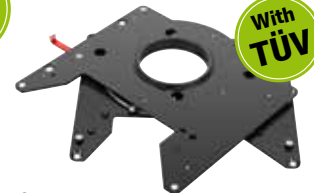

For Original seat
Driver's side: **595714** 267,-
Passenger side: **595713** 267,-
Adapter for raising the seat console
(no handbrake adapter necessary)
595715 40,50

SWIVEL BRACKETS for Maxicamper

For Mercedes-Benz Vito/Viano



Without TÜV

Swivel console for Vito Original seat

YOC. 1996 until 2003

Driver's side **594772 188,-**
Passenger side **594773 188,-**



With TÜV

Swivel console for original seat YOC. 2004 until 2015

Driver's side **59598 311,-**
Passenger side **59599 311,-**



With TÜV

Swivel console for original seat from YOC. 2015 + Sprinter from 2019

Driver's side **59596 311,-**
Passenger side **59597 311,-**

For VW Crafter from YOC. 17



With TÜV

Swivel console for original seat

Approval ECE-N1, no handbrake adapter necessary Driver side

59643 407,-
Passenger side **59644 407,-**

For Mercedes-Benz Sprinter and VW LT

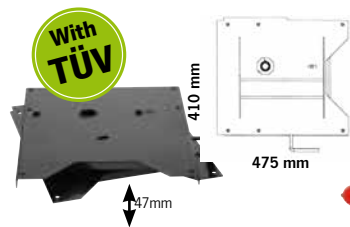

With TÜV

Swivel console for Original seat

YOC. 1996-2002

incl. handbrake lowering
Driver's side **59532 311,-**
Passenger side **59533 309,-**

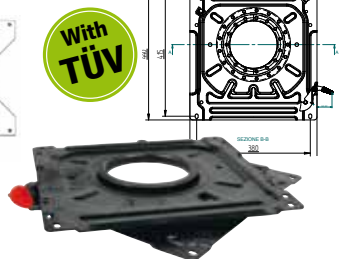

With TÜV

Swivel console for original seat

Year . 1995 (VW LT 1996) until 2006
Driver's side **59476 234,-**
Passenger side **594761 234,-**

For MB Sprinter from YOC. 06 & VW Crafter YOC. 06-16

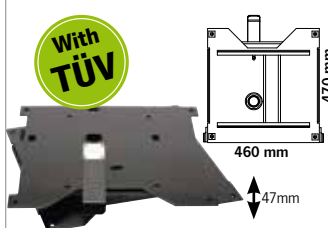

With TÜV

Rotating console for original seat

driver's side incl. Handbrake lowering
59633 312,-
Passenger side **59634 312,-**

For MB Sprinter from 2018 and VW Crafter 06-16



With TÜV

Swivel console for original seat

Tested and homologated according to R14. For driver or passenger side
59655 305,-

For Fiat Ducato type 230 Citroen Jumper Peugeot Boxer

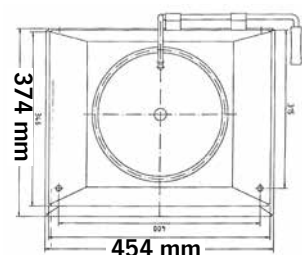

With TÜV



Art. 59547 incl. adapter

Rotating console Yr. 1995-2001
For original driver/passenger seat.

59546 349,-
With adapter for Sportscraft seat driver / passenger.
59547 389,-

For Renault Master/ Opel Movano

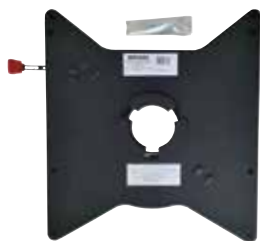

Swivel bracket from YOC. 2010

Driver side **59588 311,-**
Passenger side **595880 311,-**



H 25 mm

With TÜV

Swivel console for original seat,
YOC. 2004-2009, driver/passenger side:
59642 287,-

For VW Crafter/ MAN + 2017 (for Crafter YOC. 2017-2021)



With TÜV

For original seats

Driver's side: **595722 267,-**
Passenger side: **595719 267,-**



SWIVEL CONSOLES for Fiat Ducato/Citroën/Peugeot

For Fiat Ducato
type 244
Citroën Jumper
Peugeot Boxer

Year of manufacture
2002 - 2006



With TÜV

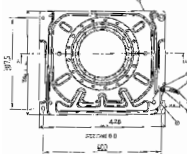

Swivel console for original seat
Driver's side **59478** 174,-
Passenger side **594781** 174,-

With TÜV

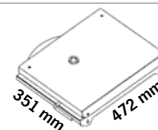

Swivel bracket for original seat Mounting between underframe and slide rail. Axtrreme center turning.
Driver's side **59573** 239,-
Passenger side **59574** 239,-

With TÜV

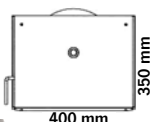

Swivel console for original seat
Mounting between base frame and slide rail.
Driver/passenger side, center rotating.
59572 239,-



With TÜV

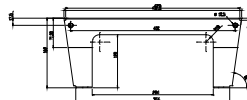

Seat box flat
Instead of original box.
59545 209,-

With TÜV

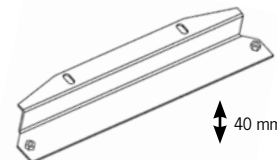

Flat adapter as replacement for original socket
Thus 40 mm lower seating position than with original seat box.
For passenger side **59549** 63,10

For Fiat Ducato
type 250
Fiat Ducato Type 290
Citroën Jumper
Peugeot Boxer

from YOC. 2006

With TÜV



Swivel console for original seat
Driver's side **59473** 232,-
Passenger side **594731** 231,50

With TÜV

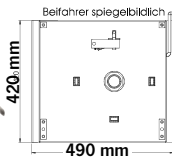
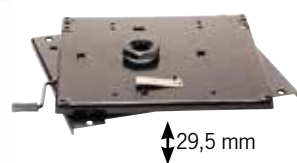

Swivel console for original seat
Driver's side & Passenger side
center rotating **59581** 279,-
Driver, turning off-center **59583** 279,-
Passenger, rotating eccentrically **59582** 279,-

With TÜV



For Sportcraft seat Mounting between base frame and slide rail.
Fs. & Bfs. center rotating **59589** 499,-
Driver's side, offset rotating **E4993** 474,-
Passenger side, offset rotating. **E4863** 474,-

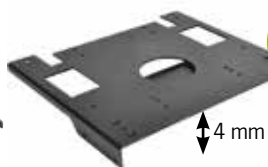

With TÜV



Standard adapter for Sportcraft seats.
59584 219,-

With TÜV

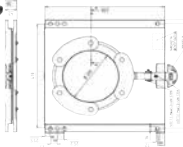

Swivel bracket for original seat FS/BFS
with test cert. acc. to e50
59698 149,-

With TÜV

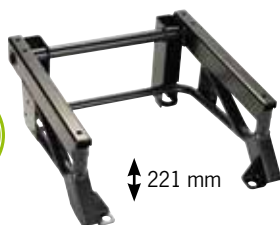

Low seat box
Mounting instead of the original undercarriage if there is no battery under the seat. Ideal in conjunction w/ swivel bracket. This base is app. 40 mm flatter than original base.

59548 257,-



For Fiat Ducato type 250X from
yr. 07/2006

Without TÜV



Swivel console for original seat
Driver's side **594702** 173,-
Passenger side **594703** 185,-

OVERVIEW OF THE SLEEPING/BENCH SEAT SYSTEMS

Welche Reimo Sitzbank passt für Ihr Fahrzeug (Die Ziffer im Kreis steht für die Fahrzeuglänge)											Fahrzeuglänge(Radstand) in mm					
Hersteller	Typ	Baujahr	baugleich	Family/Eco Festeinbau	Reimo Variotech 3100* Festeinbau	Reimo Variotech 3000*	Reimo Variotech 1000 Einzelsitze	Gurtbock 5950.10	Gurtbock 5910.1/2/3 Gurtbock 5951.5/16	Gurtbock 59250	Gurtbock 59560/61* starr montiert	Sitzbank SK7 59240, 59225 starr montiert	Fasp Divan 506* starr montiert	①=L1	②=L2	③=L3
														Citroen	Jumper II	2006-
	Jumpy	2007-	2											4805(R3000)	5143(R3122)	-
Fiat	Ducato 250	2006-	8					①-③	①-③	②	①-③	①-③	①-③	4963(R3000)	5413(R3450)	L4:5998(R4035)
	Scudo	2007-	2											4805(R3000)	5143(R3122)	-
	Talento	2016-	11			①②								4999(R3098)	5399(R3498)	-
Ford	Transit Custom	2013-		②		②	②							4971(R2933)		
	Transit	2001-2012												4863(R2993)	5230(R3300)	6403(R3750)
	Transit	2014-						①-③						5531(R3300)	5981(R3750)	6704(R3750)
Hyundai	H1	2008-												4685(R2800)	-	-
Mercedes	Viano W447	2014-	9			②								4748(R3200)	5140(R3200)	5370(R3430)
	Vito W447	2014-	9			②								4748(R3200)	5140(R3200)	5370(R3430)
	Vito (W/V639)	2003-2014	6											4748(R3200)	4993(R3200)	5223(R3430)
	Viano	2003-2014	6											4748(R3200)	4993(R3200)	5223(R3430)
	Sprinter (NCV3)	2006-	4					①-③				①		5245(R3250)	5910(R3665)	6945(R4325)
	Sprinter (T1N)	1996-2006	3					①-③				①-③	①-③	4889(R3000)	5639(R3550)	6589(R4025)
Nissan	NV300	2014-	11			①②								4999(R3098)	5399(R3498)	-
	Primastar	2001-2014	7				①							4782(R3098)	5182(R3498)	-
Opel	Vivaro X82	2014-	11			①②								4999(R3098)	5399(R3498)	-
	Vivaro	2001-2014	7											4782(R3098)	5182(R3498)	-
Peugot	Boxer II	2006-	8					①-③	①-③	②	①-③	①-③	①-③	4963(R3000)	5413(R3450)	L4:5998(R4035)
	Expert	2007-	2											4805(R3000)	5143(R3122)	-
Renault	Trafic X82	2014-	11			①②								4999(R3098)	5399(R3498)	-
	Trafic	2001-	7											4782(R3098)	5182(R3498)	-
VW	T6	2015-	10	①②	①②	①②	①②							4904(R3000)	5304(R3400)	-
	T5	2003-2015	10	①②	①②	①②	①②							4892(R3000)	5292(R3400)	-
	T4	1990-2003		①②										4707(R2920)	5107(R3320)	-
	Crafter	2006-	4					①-③				①-③	①-③	5245(R3250)	5910(R3665)	6945(R4325)
①②③	Zulassung als PKW oder Wohnmobil europaweit möglich, mit Prüfbereich für den Einbau im Fahrzeug (M1 Basis) (ECE R14 / ECE R17) Isofix vorhanden, Sitzplatzerkennung noch nicht verfügbar													*mit integrierten Dreipunkt Sicherheitsgurten ausgestattet		
①②③	Zulassung als Wohnmobil europaweit möglich, mit Prüfbereich für den Einbau im Fahrzeug (N1 Basisfahrzeug) (ECE R14 / ECE R17)															
①②③	Einbau in Fahrzeug geprüft, Zulassung als Sokfz nach STVZO in Deutschland möglich, im Ausland Einzelfall mit TÜV abklären (EG 76/115)													Stand 1.8.2022 Änderungen und Irrtümer vorbehalten		
①②③	Bank geprüft, notwendige Bodenbefestigung und Einbau für Einzelabnahme vorab mit dem jeweiligen TÜV abklären															

Bench fittings / accessories

- Special seat bench fitting VW T2/T3 YOC. 8/79-7/90**
With engine comp. elevation 12 cm to build a storage space above engine comp. W/ 2 support brackets **58001 212,-**
- Variotech special fitting:** Low overall height (app. 60 mm). The fittings are completely covered by the upholstery in the sleeping position. Very stable design with or without lifting. We use this bench seat fitting in our Variotech bench seat system. TÜV tested acc. to ECE standard 14 u. 17. Without lifting for Variotech except VW T6/5.
Without increase **58007 204,-**
With lifting **58012 160,-**
- Universal folding seat fitting**
For construction of compl. groups of benches. 3 bench positions are possible with this fitting. Conversion from a folding bench seat to a living, driving or reclining position is possible in just a few simple steps.
Universal fitting short
for bench seat in driving direction **58005 152,-**
Universal fitting long. Due to larger swivel range, this fitting bridges approx. 40 cm of free space. This makes it possible to build a bench seat with the long side directly against the vehicle wall.
58006 165,90
- Universal fitting, high rear for family bench seat** **58015 753,47**
- Bench spring, Spare part for seat bench fitting.** **58011 8,-**

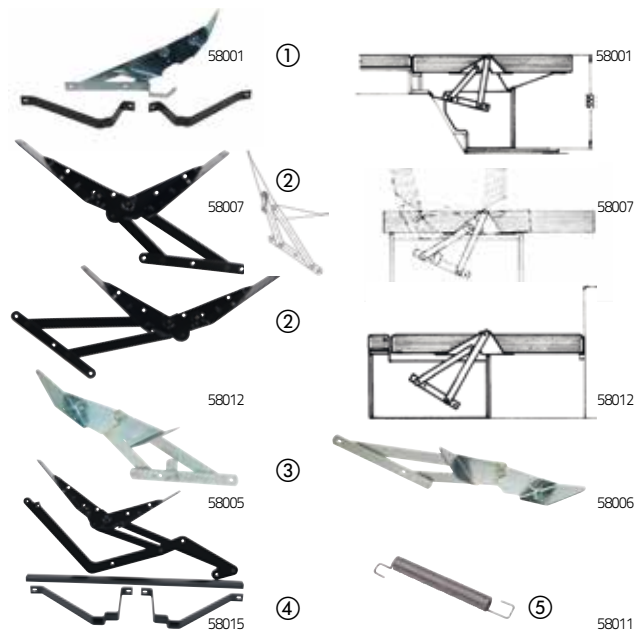

*Attention:

Since Oct. 2004, it is compulsory (for first-time registrations) for passenger cars to display on all Seats three-point belts are necessary.
Medium seats w/ lap belts are therefore only to be registered if vehicle is registered as a special motorhome.
The test was performed without head restraints, since head restraints are not mandatory even for passenger cars on rear seats.

Notice:

Each installed bench must be inspected at the TÜV. Our expert opinions also confirm the mounting in the vehicle for some vehicle types (see above).
For other vehicles, an expert can approve the attachment in the vehicle analogously.
Recommendation: This is easier if the installation is carried out according to our tested models.
If in doubt, talk to your expert in advance.

TERMS AND CONDITIONS

1. Scope

1.1 The deliveries and services of Reimo Reiseumobil-Center GmbH are subject to the following terms and conditions. Our terms and conditions apply exclusively. Any deviating, conflicting or supplementary terms and conditions of the customer shall not apply, unless we explicitly approve their validity. This applies even if we unreservedly provide the customer with a delivery or service despite being aware of the customer's terms and conditions.

1.2 Unless explicitly stated otherwise in the following clauses, these terms and conditions apply both to "traders", as defined in Section 14 of the German Civil Code (BGB), and to legal persons incorporated under public law or investment funds incorporated under public law, as well as to "consumers", as defined in Section 13 BGB. A "consumer" means any natural person who enters into a legal transaction for purposes that predominantly are outside the consumer's trade, business or profession. A "trader" means a natural or legal person or a partnership with legal personality who or which, when concluding a legal transaction, acts in exercise of their trade, business or profession.

2. Conclusion of Contract

2.1 Our offers shall be subject to change. If the customer makes an offer to enter into a contract by placing an order, the relevant contract shall only be established when we accept the offer.

2.2 If an order is placed via our website (www.reimo.de), the following provisions shall apply to the conclusion of the contract in addition to those specified in Section 2.1 above:

The presentation of items on our website shall not constitute a binding offer. The customer may select goods on our website and place them in the virtual shopping cart by clicking on the shopping cart symbol. By clicking on the "Buy now" button, the customer shall make a binding offer to purchase the goods in the shopping cart. The customer may view and change the relevant data at any time before submitting the order.

The customer shall receive an automated email from us to confirm receipt of the order. The automatic confirmation of receipt shall merely document the fact that we have received the customer's order; it shall not mean that we accept the customer's offer to enter into a contract. The contract shall only be established when we submit a declaration of acceptance, which shall be sent as an order confirmation in a separate email. Any contracts facilitated via our website shall be concluded in German.

2.3 All agreements made between us and the customer when entering into the contract shall be fully documented in writing in the contract, including these terms and conditions. Our employees shall not be authorised to make any verbal agreements that deviate from the contract or supplement its provisions.

2.4 We reserve the right to make insignificant changes to components, the design, the colour or other details as part of technical developments, provided such changes are reasonable for the customer, taking into account the interests of both parties. In particular, any such changes must not lead to a reduction in value or an impairment of use.

2.5 Due to the use of natural raw materials, all weight specifications shall be within the usual tolerances of +/- 5%.

3. Prices and Terms of Payment

3.1 Prices and terms of payment for contracts with consumers

(a) The prices indicated for consumers in our online shop and any other prices offered to consumers shall be gross prices quoted in EUROES ex works plus any additional shipping costs that may be indicated. If an order is placed via our website, the respective shipping costs shall be specified in our online shop.

(b) If a consumer places an order via our online shop, we shall offer the following payment methods: PayPal, credit card (MasterCard or Visa) or *Sofortüberweisung*. If we enter into a contract with a consumer in a brick-and-mortar shop, the purchase price must be paid in cash or by EC card upon delivery.

3.2 Prices and terms of payment for contracts with traders

(a) If we make a trader an offer, the prices offered shall be net prices quoted in EUROES ex works, unless stated otherwise. If applicable, the statutory rate of value added tax shall be shown separately on our invoice.

(b) The following terms of payment apply to contracts with traders: Our invoices shall be payable without deductions within 30 days of receipt. If payment is received within 8 days of invoicing, we shall grant a 2% discount for early payment. We shall grant a 3% discount for cash payments, advance payments and successful payment collection based on a SEPA direct debit mandate.

3.3 General terms of payment for consumers and traders

Regardless of whether the customer is a consumer or a trader, the following terms of payment shall also apply:

(a) If the customer defaults on payment, we shall be entitled to charge default interest at the applicable statutory rate. We also reserve the right to assert further claims due to the delay.

(b) The customer shall only be entitled to offset our claims against the customer's own counterclaims – or to assert a right of retention – if the customer's counterclaims are legally established, undisputed or recognised by us. However, this restriction does not apply to any counterclaims held by the customer due to defects or the partial non-fulfilment of the contract, provided the claims are based on the same contractual relationship as our claims. The right to offset any claims arising from the exercise of the consumer's right of withdrawal, as described in Section 13 below, also remains unaffected.

(c) If it becomes apparent that our claim to the purchase price is jeopardised by the customer's solvency after entering into the contract, we shall be entitled to refuse performance in accordance with the statutory provisions and, if the customer neither pays the purchase price nor provides security within a reasonable period set by us, we shall be entitled to withdraw from the contract (Section 321 BGB).

(d) In the case of contracts for the delivery of complete vehicles, the following also applies: If a delivery date is agreed more than four months after the conclusion of the contract, and if our suppliers increase their prices during this period after the conclusion of the contract for reasons not attributable to us, we shall be entitled to pass on these increased costs to the customer and to adjust our price accordingly. We shall immediately inform the customer.

4. Delivery and Service Deadlines

4.1 We shall only adhere to our delivery and service deadlines if the customer properly fulfils their own obligations in a timely manner.

4.2 Any events for which we are not responsible and which prevent us from providing our services (e.g. strikes, lawful lockouts, official orders, natural disasters and other examples of force majeure) shall release us from our contractual obligations as long as the hindrance persists. We agree to inform the customer immediately about the occurrence and expected duration of such events. If such an event persists for longer than three months, each party shall be entitled to withdraw from the contract. In such cases, any consideration that has already been provided shall be refunded immediately.

4.3 If we default on a delivery or service due to slight negligence, our obligation to compensate for any damage caused by the delay (compensation in addition to performance) shall be limited to a maximum of 5% of the net purchase price of the delayed delivery or service. Our liability for culpable injury to life, limb or health remains unaffected. Our liability for compensation in lieu of performance shall be governed by the provisions of Section 5 of these terms and conditions.

4.4 The delivery of goods is also subject to the provisions of Section 8 (see Part II below).

5. Liability

5.1 We shall be liable in accordance with the statutory provisions if the customer asserts any claims for damages based on intent or gross negligence – including intent or gross negligence on the part of our legal representatives, employees or other vicarious agents – or based on the culpable breach of an essential contractual duty. Essential contractual duties are those which must be observed to achieve the purpose of the contract and on the observance of which the customer may regularly depend. If we are not guilty of intent or gross negligence, our liability for damages in the above cases shall be limited to the foreseeable degree of damage that typically occurs.

5.2 In the case of liability for culpable injury to life, limb or health, the statutory provisions shall remain unaffected; the same applies to cases of mandatory liability under the German Product Liability Act (ProdHaftG).

5.3 Unless otherwise stipulated above, we shall not be liable for any damages regardless of the legal nature of the claim in question. In case of default, our liability shall also be subject to the limitations described in Section 4.3 above.

5.4 The above provisions shall apply accordingly if the customer demands compensation of wasted expenses instead of claiming compensation for damages in lieu of performance.

5.5 If our liability for damages is excluded or limited, this shall also apply with regard to the personal liability of our legal representatives, employees and vicarious agents.

6. Information Provided by Telephone

Any information provided by telephone shall generally be non-binding and without guarantee if we offer an assessment after the matter in question is described by telephone, verbally or in writing and if we have no opportunity to conduct a detailed inspection of the item to which the information relates.

Part II: Special Provisions for Deliveries of Vehicles, Accessories and Spare Parts

7. Special Orders and Custom-Made Vehicles

A deposit of 25% of the purchase price shall be due when a contract is established for special vehicle orders; a deposit of 40% of the purchase price shall be due when a contract is established for custom-made vehicles. Any custom-made vehicles shall be manufactured according to the plans and measurements provided by the customer. The customer shall be solely responsible for the correctness of such measurements.

8. Delivery and Transfer of Risk

8.1 Our deliveries shall be made ex works. The risk of accidental loss or deterioration shall be transferred to the customer, at the latest, when the goods are handed over to the customer. If we ship the goods at the customer's request, the risk shall be transferred to the customer when the goods are handed over to the freight carrier or another person instructed to transport the goods. The statutory transfer of risk in the event of default in acceptance remains unaffected. If the customer is a consumer, the risk in the cases described in the third sentence above shall only be transferred to the customer as soon as the goods are handed over to the freight carrier or another person instructed to transport the goods if the customer has instructed the freight carrier or the other person to carry out the shipping and we have not previously named the transporting person to the customer.

8.2 Unless stated otherwise, any parts ordered via our website shall be delivered within 5 working days.

8.3 We shall be entitled to make partial deliveries if they are reasonable for the customer.

8.4 If the customer requests a different design of the purchased item before it is delivered, the delivery period shall be interrupted until an understanding is reached on the required design; if necessary, the deadline shall be extended by the time required to implement the different design.

8.5 If an agreed, non-binding delivery date is exceeded by more than 6 weeks in the case of a contract for the delivery of vehicles, the customer shall be entitled to set us a reasonable grace period. If we do not deliver the purchased item by the end of the grace period, the customer may withdraw from the contract by means of a written declaration and/or demand compensation in lieu of performance under the legal regulations.

9. Conditions of Acceptance for the Delivery of Vehicles

9.1 If the customer fails to accept a purchased item within 14 days of being notified of its availability, or if the customer refuses to accept the delivery, we shall be entitled to withdraw from the contract and/or to demand compensation due to non-performance after a reasonable grace period set by us.

9.2 In the latter case, we shall be entitled to claim 15% of the purchase price as compensation for damages – without prejudice to the possibility of demanding a greater amount for the damage that is actually incurred. The customer reserves the right to prove that we have incurred significantly less or no damage.

10. Retention of Title

10.1 The goods shall remain our property until the purchase price has been paid in full. By way of derogation from the first sentence, the following shall apply if the customer is a trader: The goods shall remain our property until all claims arising from the business relationship between us and the customer, including any additional claims, have been settled in full. The retention of title shall remain in effect even if some of our claims are included in a current account and the balance has been determined and recognised.

10.2 The customer shall not be permitted to pledge any goods subject to retention of title or assign them as security. We must be immediately notified of any seizures or other third-party interventions. If the third party is unable to reimburse us for the judicial and extra-judicial costs of averting the intervention in question, the customer shall be liable for the loss we incur.

10.3 The customer shall store any goods subject to retention of title for us free of charge. The customer must insure them against common risks such as fire, theft and water with the usual degree of coverage. The customer hereby assigns to us any compensation claims held against insurance companies or any other parties liable for compensation due to any damages of the type described above; the assigned claims shall correspond to the amount of the customer's own claims.

10.4 If the customer fails to meet their payment obligations, we shall be entitled to withdraw from the contract and demand the return of the goods subject to retention of title under the legal requirements.

10.5 If the customer is a trader, the following provisions also apply:

(a) The customer shall be entitled to process and sell any goods subject to retention of title in accordance with the following provisions:

(b) The customer hereby assigns to us any claims arising from the resale of goods subject to retention of title corresponding to the final amount invoiced for our own claims (including VAT); this shall also apply proportionately if the goods are processed, mixed or combined with other items and we acquire co-ownership in the amount of their invoice value. In the latter case, we shall be entitled to a fraction of the respective purchase price claim arising from the resale in the ratio of the invoice value of our goods subject to retention of title to the total invoice value of the item in question. If the customer sells the claim as part of real factoring, the customer shall assign to us the claim held against the factor that replaces it. We shall accept the assignment.

(c) We shall not collect any assigned claims as long as the customer meets their payment obligations. The customer shall remain entitled to collect the claims. However, the customer shall no longer be authorised to collect the claims if the customer defaults on payment or if an application is filed for insolvency proceedings against the customer's assets. In such cases, we may ask the customer to notify us of the assigned claims and the debtors, to provide all information required to collect the receivables, to hand over the associated documents, and to inform the debtors that the claims have been assigned to us.

(d) By processing goods subject to retention of title, the customer shall not acquire ownership of the new item pursuant to Section 950 BGB. Any such processing shall be done for us; however, this shall not result in any liabilities for us. If any goods subject to retention of title are processed, mixed or combined with other items, we shall acquire co-ownership of the new item in the ratio of the value of the goods subject to retention of title to the total value of the goods. The customer shall no longer be authorised to process goods subject to retention of title in the ordinary course of business if the customer stops making payments or if an application is filed for insolvency proceedings against the customer's assets.

(e) We agree to release the securities to which we are entitled if their value exceeds the claims to be secured by more than 20%. We shall be responsible for choosing the securities to be released.

11. Warranty for Contracts of Sale

11.1 If any defects are found in our goods, the customer shall have the statutory warranty rights described in Section 434 et seq. BGB; however, the customer shall only be able to assert any claims for damages to the extent specified in Section 5 above.

11.2 If the customer is a trader, the following provisions also apply:

(a) The customer shall only be able to assert any warranty claims after properly fulfilling their obligation to inspect the goods and report defects in accordance with Section 377 of the German Commercial Code (HGB). The customer shall be obliged to inspect the purchased items as soon as they are received. Any defects must be reported immediately. Otherwise, the goods shall be deemed to have been accepted in perfect condition, unless the defect was not apparent during the inspection. Any installed parts shall not be replaced or repaired if damage would have been detected upon careful inspection prior to installation. Any hidden defects that were not apparent during a proper inspection must be reported as soon as they are discovered. Any defects must always be reported in writing.

(b) If a purchased item is defective and the defect is properly reported by the customer, we shall be able to choose whether to deliver a replacement or make a repair. We shall acquire ownership of any replaced parts. The place of subsequent performance shall be our registered office. The customer shall only be entitled to withhold payments due to a defect to an extent that is appropriate in relation to the defect and in relation to the cost of rectifying the situation.

(c) The customer shall only be entitled to assert any warranty claims if the customer can prove that the goods were defective when the risk was transferred. In particular, we shall not be liable for any damage caused by improper use, incorrect assembly, inadequate or incorrect maintenance, or any damage caused by natural wear and tear or unauthorised changes to purchased items (e.g. self-assembly, installation of equipment and accessories).

(d) The warranty period applicable to claims for defects shall be 12 months from the delivery of the item in question. By way of derogation from the above, the statutory warranty period of two years shall apply to any claims for damages due to intentional or grossly negligent breaches of duty or culpable injury to life, limb or health. The statutory limitation period in the case of recourse against the supplier (recourse by a trader) remains unaffected.

11.3 We shall only assume any guarantees if this is explicitly stated for the selected product. The details of each guarantee can be found in the relevant guarantee conditions. Any guarantees shall apply in addition to statutory warranty rights.

12. Agreements on Returns for Traders

If the customer is a trader, the following applies with regard to returns: Unless there is a warranty claim, any goods may only be returned with our prior, written consent; the returned goods must be accompanied by a copy of the invoice. In such cases, the return shipping costs must be borne by the customer. Unless otherwise agreed, the customer shall also be obliged to pay 15% of the purchase price in such cases.

13. Cancellation Right for Consumers

If the customer is a consumer who enters into a contract with us via our website, the customer shall be entitled to cancel their order under the following conditions:

Cancellation Policy

The customer shall be entitled to cancel the contract within fourteen days without stating their reason for doing so. The fourteen-day cancellation period shall begin on the day the goods are handed over to the customer or a third party designated by the customer, excluding the carrier. In case of a contract for several goods that are requested by the customer as part of a single order and that are delivered separately, the fourteen-day cancellation period shall begin on the day the last goods are handed over to the customer or a third party named by the customer, excluding the carrier.

In order to exercise the cancellation rights described above, the customer must send us a clear statement (e.g. a letter sent by post, fax or email) regarding their decision to withdraw from the contract; we can be contacted as follows: Reimo Reiseumobil-Center GmbH, Lieferzentrum, Abt. Retouren, Am Rotböll 17-19, D-64331 Weiterstadt; Fax: +49 6150 8662-329; Tel.: +49 6150 8662-367; Email: shop@reimo.com. The customer may use the attached cancellation form template, but this is not mandatory.

In order to meet the deadline, the customer must merely submit the statement outlining their intention to cancel the contract before the end of the cancellation period.

Ramifications of cancellation:

If the customer cancels the contract, we shall reimburse any payments received from the customer, including shipping costs (except for any additional costs incurred if the customer does not choose our cheap standard shipping); we shall make the refund immediately – and at the latest within fourteen days of receiving notification of their intention to cancel the contract. We shall make the refund with the same payment method used by the customer for the original transaction, unless alternative arrangements are explicitly agreed with the customer; under no circumstances shall the customer be charged any fees for the refund.

We may refuse to make a refund until we have received the returned goods or until the customer has provided evidence to prove that the goods have been returned, whichever comes first.

The customer must return or hand over the goods immediately – and at the latest within fourteen days of notifying us of the cancellation of the contract. The deadline shall be met if the customer sends off the goods before the end of the fourteen-day period.

The costs directly associated with the return shipment shall be borne by the customer.

If goods cannot be sent by parcel and cannot be returned normally by post, we shall offer to collect the goods from the customer at our expense.

The customer must only pay for any depreciation of the goods if the loss of value is caused by the use of the goods in a manner that is not necessary to check their quality, properties and functionality.

Part II: Special Provisions for Services Involving Work Performed on Items Not Procured By Us

14. Customer's Obligation to Cooperate

14.1 If the customer places an order for the provision of services involving work performed on items not procured by us, the customer must make the vehicle available to us at the agreed time in a condition suitable for performing the work.

14.2 If the vehicle needs to be cleaned before the work specified in the order can be performed, and if the cleaning is done by us, we shall be entitled to invoice the customer for this.

14.3 In the case of orders involving assembly, the vehicle must be in factory or standard condition and must be delivered in a completely empty state. We shall not be liable for any moving parts found in the vehicle contrary to this agreement, unless the customer can prove that we are guilty of intent or gross negligence. An additional charge shall be incurred for any work required to create or compensate for this condition (e.g. damaged vehicle).

14.4 In the case of orders involving assembly and repair, the cost estimate may be exceeded by up to 15% if any unforeseen circumstances arise during the work and we are unable to consult the customer at short notice. The customer's rights pursuant to Section 649 BGB shall otherwise remain unaffected.

14.5 Unless otherwise agreed, we shall immediately dispose of any removed parts for a fee.

15. Collection and Acceptance

15.1 The customer shall be obliged to collect the object of the order no later than one week after receiving notification that the order is complete. The customer shall be obliged to formally accept the work performed in accordance with the contract. Unless otherwise agreed, the formal acceptance procedure with the customer shall take place at our registered office. The customer must not refuse acceptance due to insignificant defects.

15.2 In the event of non-acceptance, we shall be entitled to assert our statutory rights without restriction. In particular, we shall be entitled to charge the usual local storage costs. If the customer defaults on acceptance, the risk shall be transferred to the customer.

16. Warranty for Services Involving Work Performed on Items Not Procured By Us

If any service involving work performed on items not procured by us proves to be inadequate, the customer shall be able to assert their statutory warranty rights; however, the customer shall only be able to assert any claims for damages to the extent specified in Section 5 above. The warranty period shall be one year from acceptance. By way of derogation from the above, the statutory warranty period shall apply to any claims for damages due to intent, gross negligence or culpable injury to life, limb or health.

Part IV: Final Provisions

17. Place of Jurisdiction and Applicable Law

17.1 If the customer is a merchant, a legal person incorporated under public law or an investment fund incorporated under public law, the courts at our registered office shall be the place of jurisdiction for any disputes arising from or in connection with the contract. This agreement on the place of jurisdiction applies exclusively to the customer. We shall also be entitled to take legal action against the customer at their general place of jurisdiction.

17.2 These terms and conditions are subject to the law of the Federal Republic of Germany to the exclusion of the United Nations Convention on Contracts for the International Sale of Goods (CISG). If the customer is a consumer whose habitual residence is located in a country other than Germany at the time the order is placed, however, the application of the mandatory legal provisions of the country in question shall remain unaffected by the choice of law identified in the first sentence.

18. Dispute Resolution in Consumer Contracts

18.1 The European Commission has created an online dispute resolution platform that serves as a point of contact for the out-of-court settlement of disputes with consumers in relation to contractual obligations arising from online contracts. This is available here: <http://ec.europa.eu/consumers/odr/>.

18.2 We are neither obliged nor willing to participate in dispute resolution proceedings before a consumer arbitration board under the German Act on Alternative Dispute Resolution in Consumer Matters (VSBG).

19. Severability Clause

If any provisions of these terms and conditions prove to be ineffective, this shall have no bearing on the effectiveness of the remaining provisions. Any ineffective provisions shall be replaced by the statutory provisions.

*Reimo online store
for camper van conversion*
www.reimo.com

Discover the complete range of extensions
at www.reimo.com

- ▶ Complete camper van furniture and kitchen modules
- ▶ Camping modules and kits for self-installation
- ▶ Huge selection of vehicle roofs
- ▶ Seat/sleeper bench systems for many vehicle brands
- ▶ Finishing materials and technical components



Scan the QR code and
full range of Reimo extensions
experience online!



Deliveries are subject to change.
All prices in Euro incl. VAT.
All items without decoration.
Subject to technical developments
and printing errors.
Status: January 2024

www.reimo.com